



ALTAIR

ONLY FORWARD

Altair Feko 2023.1

Comprehensive Release Notes

Updated: 12/06/2023

[altair.com](https://www.altair.com)

Intellectual Property Rights Notice

Copyright © 1986-2023 Altair Engineering Inc. All Rights Reserved.

This Intellectual Property Rights Notice is exemplary, and therefore not exhaustive, of the intellectual property rights held by Altair Engineering Inc. or its affiliates. Software, other products, and materials of Altair Engineering Inc. or its affiliates are protected under laws of the United States and laws of other jurisdictions. In addition to intellectual property rights indicated herein, such software, other products, and materials of Altair Engineering Inc. or its affiliates may be further protected by patents, additional copyrights, additional trademarks, trade secrets, and additional other intellectual property rights. For avoidance of doubt, copyright notice does not imply publication. Copyrights in the below are held by Altair Engineering Inc. or its affiliates. Additionally, all non-Altair marks are the property of their respective owners.

This Intellectual Property Rights Notice does not give you any right to any product, such as software, or underlying intellectual property rights of Altair Engineering Inc. or its affiliates. Usage, for example, of software of Altair Engineering Inc. or its affiliates is governed by and dependent on a valid license agreement.

Altair HyperWorks®, a Design & Simulation Platform

Altair® AcuSolve® ©1997-2023

Altair® Activate® ©1989-2023

Altair®Twin Activate® ©1989-2023

Altair® Automated Reporting Director™ ©2008-2022

Altair® Battery Designer™ ©2019-2023

Altair® CFD™ ©1990-2023

Altair® Compose® ©2007-2023

Altair® ConnectMe™ ©2014-2023

Altair® DesignAI™ ©2022-2023

Altair® EDEM™ ©2005-2023

Altair® EEvision™ ©2018-2023

Altair® ElectroFlo™ ©1992-2023

Altair® Embed® ©1989-2023

Altair® Embed® SE ©1989-2023

Altair® Embed®/Digital Power Designer ©2012-2023

Altair® Embed® Viewer ©1996-2023

Altair® e-Motor Director™ ©2019-2023

Altair® ESAComp® ©1992-2023

Altair® expertAI™ ©2020-2023

Altair® Feko® ©1999-2023

Altair® Flow Simulator™ ©2016-2023
Altair® Flux® ©1983-2023
Altair® FluxMotor® ©2017-2023
Altair® GateVision PRO™ ©2002-2023
Altair® Geomechanics Director™ ©2011-2022
Altair® HyperCrash® ©2001-2023
Altair® HyperGraph® ©1995-2023
Altair® HyperLife® ©1990-2023
Altair® HyperMesh® ©1990-2023
Altair® HyperSpice™ ©2017-2023
Altair® HyperStudy® ©1999-2023
Altair® HyperView® ©1999-2023
Altair® HyperView Player® ©2022-2023
Altair® HyperWorks® ©1990-2023
Altair® HyperMesh® CFD ©1990-2023
Altair® HyperWorks® Design Explorer ©1990-2023
Altair® HyperMesh® NVH ©1990-2023
Altair® HyperXtrude® ©1999-2023
Altair® Impact Simulation Director™ ©2010-2022
Altair® Inspire™ ©2009-2023
Altair® Inspire™ Cast ©2011-2023
Altair® Inspire™ Extrude Metal ©1996-2023
Altair® Inspire™ Extrude Polymer ©1996-2023
Altair® Inspire™ Form ©1998-2023
Altair® Inspire™ Mold ©2009-2023
Altair® Inspire™ PolyFoam ©2009-2023
Altair® Inspire™ Print3D ©2021-2023
Altair® Inspire™ Render ©1993-2023
Altair® Inspire™ Studio ©1993-2023
Altair® Material Data Center™ ©2019-2023
Altair® Model Mesher Director™ ©2010-2023
Altair® MotionSolve® ©2002-2023
Altair® MotionView® ©1993-2023

Altair® Multi-Disciplinary Optimization Director™ ©2012-2023

Altair® Multiscale Designer® ©2011-2023

Altair® newFASANT™ ©2010-2020

Altair® nanoFluidX® ©2013-2023

Altair® NVH Director™ ©2010-2023

Altair® NVH Full Vehicle™ ©2022-2023

Altair® NVH Standard™ ©2022-2023

Altair® OptiStruct® ©1996-2023

Altair® physicsAI™ ©2021-2023

Altair® PolIEx™ ©2003-2023

Altair® PSIM® ©2001-2023

Altair® Pulse™ ©2020-2023

Altair® Radioss® ©1986-2023

Altair® romAI™ ©2022-2023

Altair® RTLvision PRO™ ©2002-2023

Altair® S-CALC™ ©1995-2023

Altair® S-CONCRETE™ ©1995-2023

Altair® S-FRAME® ©1995-2023

Altair® S-FOUNDATION™ ©1995-2023

Altair® S-LINE™ ©1995-2023

Altair® S-PAD™ ©1995-2023

Altair® S-STEEL™ ©1995-2023

Altair® S-TIMBER™ ©1995-2023

Altair® S-VIEW™ ©1995-2023

Altair® SEAM® ©1985-2023

Altair® shapeAI™ ©2021-2023

Altair® signalAI™ ©2020-2023

Altair® Silicon Debug Tools™ ©2018-2023

Altair® SimLab® ©2004-2023

Altair® SimLab® ST ©2019-2023

Altair® SimSolid® ©2015-2023

Altair® SpiceVision PRO™ ©2002-2023

Altair® Squeak and Rattle Director™ ©2012-2023

Altair® StarVision PRO™ ©2002-2023

Altair® Structural Office™ ©2022-2023

Altair® Sulis™ ©2018-2023

Altair® ultraFluidX® ©2010-2023

Altair® Virtual Gauge Director™ ©2012-2023

Altair® Virtual Wind Tunnel™ ©2012-2023

Altair® Weight Analytics™ ©2013-2023

Altair® Weld Certification Director™ ©2014-2023

Altair® WinProp™ ©2000-2023

Altair® WRAP™ ©1998-2023

Altair HPCWorks®, a HPC & Cloud Platform

Altair® Allocator™ ©1995-2023

Altair® Access™ ©2008-2023

Altair® Accelerator™ ©1995-2023

Altair® Accelerator™ Plus ©1995-2023

Altair® Breeze™ ©2022-2023

Altair® Cassini™ ©2015-2023

Altair® Control™ ©2008-2023

Altair® Desktop Software Usage Analytics™ (DSUA) ©2022-2023

Altair® FlowTracer™ ©1995-2023

Altair® Grid Engine® ©2001, 2011-2023

Altair® Hero™ ©1995-2023

Altair® Mistral™ ©2022-2023

Altair® Monitor™ ©1995-2023

Altair® NavOps® ©2022-2023

Altair® PBS Professional® ©1994-2023

Altair® PBS Works™ ©2022-2023

Altair® Software Asset Optimization (SAO) ©2007-2023

Altair® Unlimited™ ©2022-2023

Altair® Unlimited Data Analytics Appliance™ ©2022-2023

Altair RapidMiner®, a Data Analytics & AI Platform

Altair® Analytics Workbench™ ©2002-2023

Altair® Knowledge Hub™ ©2017-2023

Altair® Knowledge Studio® ©1994-2023
Altair® Knowledge Studio® for Apache Spark ©1994-2023
Altair® Knowledge Seeker™ ©1994-2023
Altair® Monarch® Classic ©1996-2023
Altair® Monarch® Data Prep Studio ©2015-2023
Altair® Monarch Server™ ©1996-2023
Altair® Panopticon™ ©2004-2023
Altair® Panopticon™ BI ©2011-2023
Altair® SLC™ ©2002-2023
Altair® SLC Hub™ ©2002-2023
Altair® SmartWorks™ ©2002-2023
Altair® RapidMiner® ©2001-2023
Altair® RapidMiner® AI Hub ©2001-2023
Altair® RapidMiner® Cloud ©2001-2023
Altair® RapidMiner® Studio ©2001-2023
Altair One® ©1994-2023
Altair® License Utility™ ©2010-2023

2023.1

September 14, 2023

Technical Support

Altair provides comprehensive software support via web FAQs, tutorials, training classes, telephone, and e-mail.

Altair One

Altair One (<https://altairone.com/>) is Altair's customer portal giving you access to the Marketplace, the Community, Managed Licenses, Altair Drive, My Apps, and the Learning Center. We recommend that all users create an Altair One account and use it as their primary portal for everything Altair.

Altair Community

Visit the Altair Community (<https://community.altair.com/community>) where you can participate in forums, share insights, access knowledge base articles, and contact Support. Once you login to the Altair Community, subscribe to the forums and user groups to get up-to-date information about release updates, upcoming events, and questions asked by your fellow members.

These valuable resources help you discover, learn and grow, all while having the opportunity to network with fellow explorers like yourself.

Once your Altair One account is set up, use this link to access the Altair support page: www.altair.com/customer-support/

Altair Learning

Altair's in-person, online, and self-paced trainings provide hands-on introduction to our products, focusing on overall functionality. Trainings are conducted at our corporate and regional offices.

For more information visit: <https://learn.altair.com/>

If you are interested in training at your facility, contact your account manager or technical specialist for more details.

Telephone and E-mail

If you are unable to contact Altair support via the customer portal, you may reach out to technical support via phone or e-mail. Use the following table as a reference to locate the support office for your region.

Altair support portals are available 24x7 and our global support engineers are available during normal Altair business hours in your region.

When contacting Altair support, specify the product and version number you are using along with a detailed description of the problem. It is beneficial for the support engineer to know what type of workstation, operating system, RAM, and graphics board you have, so include that in your communication.

Location	Telephone	E-mail
Australia	+61 3 9866 5557	anzsupport@altair.com
Brazil	+55 113 884 0414	br_support@altair.com

Location	Telephone	E-mail
Canada	+1 416 447 6463	support@altairengineering.ca
China	+86 400 619 6186	support@altair.com.cn
France	+33 141 33 0992	francesupport@altair.com
Germany	+49 703 162 0822	hwsupport@altair.de
Greece	+30 231 047 3311	eesupport@altair.com
India	+91 806 629 4500	support@india.altair.com
Israel		israelsupport@altair.com
Italy	+39 800 905 595	support@altairengineering.it
Japan	+81 3 6225 5830	jp-support@altair.com
Malaysia	+60 32 742 7890	aseansupport@altair.com
Mexico	+52 55 5658 6808	mx-support@altair.com
New Zealand	+64 9 413 7981	anzsupport@altair.com
South Africa	+27 21 831 1500	support@altair.co.za
South Korea	+82 704 050 9200	support@altair.co.kr
Spain	+34 910 810 080	support-spain@altair.com
Sweden	+46 46 460 2828	support@altair.se
United Kingdom	+44 192 646 8600	support@uk.altair.com
United Kingdom/Data Analytics	+44 (0) 8081 892481 +44 203 868 0230	dasupport@altair.com
United States	+1 248 614 2425	hwsupport@altair.com
United States/Data Analytics	+1-800-988-4739 +1 978.275.8350	dasupport@altair.com

If your company is being serviced by an Altair partner, you can find that information on our web site at <https://www.altair.com/PartnerSearch/>.

See www.altair.com for complete information on Altair, our team, and our products.

Release Notes: Altair Feko 2023.1

1

Altair Feko 2023.1 is available with an assortment of new features, corrections and improvements. Altair Feko 2023.1 is a major release. It can be installed alongside other instances of Altair Feko.

This chapter covers the following:

- [Highlights of the 2023.1 Release](#) (p. 10)
- [Feko 2023.1 Release Notes](#) (p. 13)
- [WinProp 2023.1 Release Notes](#) (p. 18)
- [newFASANT 2023.1 Release Notes](#) (p. 19)
- [WRAP 2023.1 Release Notes](#) (p. 20)

Feko is a powerful and comprehensive 3D simulation package intended for the analysis of a wide range of electromagnetic radiation and scattering problems. Applications include antenna design, antenna placement, microstrip antennas and circuits, dielectric media, scattering analysis, electromagnetic compatibility studies including cable harness modelling and many more.

newFASANT complements Altair's high frequency electromagnetic software tool (Altair Feko) for general 3D EM field calculations, including, among others, special design tools tailored for specific applications like complex radomes including FSS, automated design of reflectarrays and ultra-conformed reflector antennas, analysis of Doppler effects, ultrasound systems including automotive or complex RCS, and antenna placement problems. Advanced solver technologies like the MoM combined with the characteristic basis functions (CBFS), PO/GO/PTD, GTD/PO and MLFMM parallelised through MPI/OpenMP, being some of them especially efficient for the analysis of electrically very large problems.

WinProp is the most complete suite of tools in the domain of wireless propagation and radio network planning. With applications ranging from satellite to terrestrial, from rural via urban to indoor radio links, WinProp's innovative wave propagation models combine accuracy with short computation times.

WRAP is a comprehensive tool for electromagnetic propagation, antenna collocation and spectrum management. WRAP combines propagation analysis, often over large areas with many transmitters and receivers, with system analysis to include complex non-linear equipment properties.

Highlights of the 2023.1 Release

The most notable extensions and improvements to Feko, newFASANT, WinProp and WRAP in the 2023.1 release.

Salient Features in Feko

- Feko's combined MoM/MTL cable solution method is extended so that the outermost shield signals of different paths in the harness may be connected to each other through a closed shielded conducting enclosure of arbitrary shape defined in the 3D full wave model. Full coupling is considered between the cable harness, the shielded enclosure and the environment. Non-radiating electrical and circuit connections between different cable path signals can be defined in a schematic view - effectively modelling connections and circuitry within the shielded enclosure.

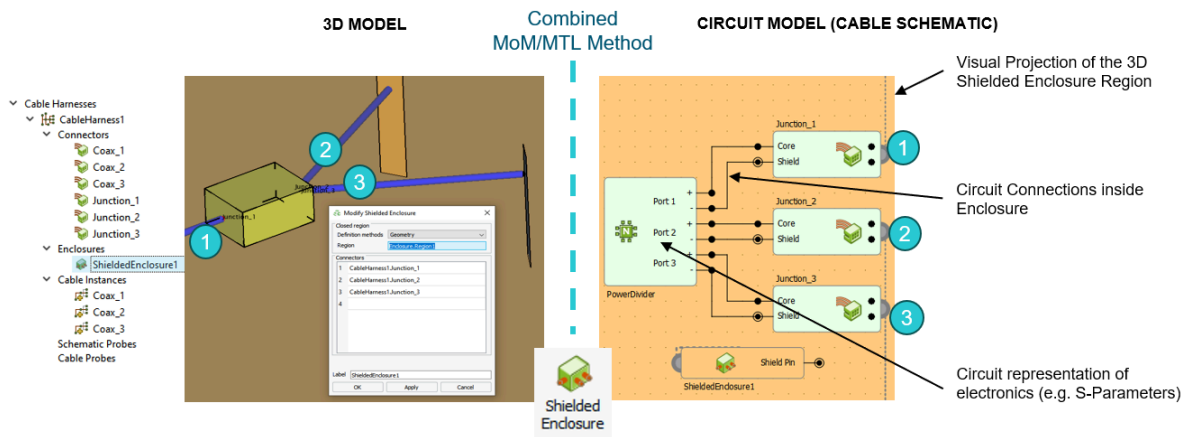

Figure 1: Illustration of the new shielded enclosure functionality in Feko.

- The following components were added to the component library:
 - A generic car model
 - A "shark fin" antenna system for cellular, GNSS, SDARS, V2X and WLAN, typical in automotive applications
 - A generic windmill model

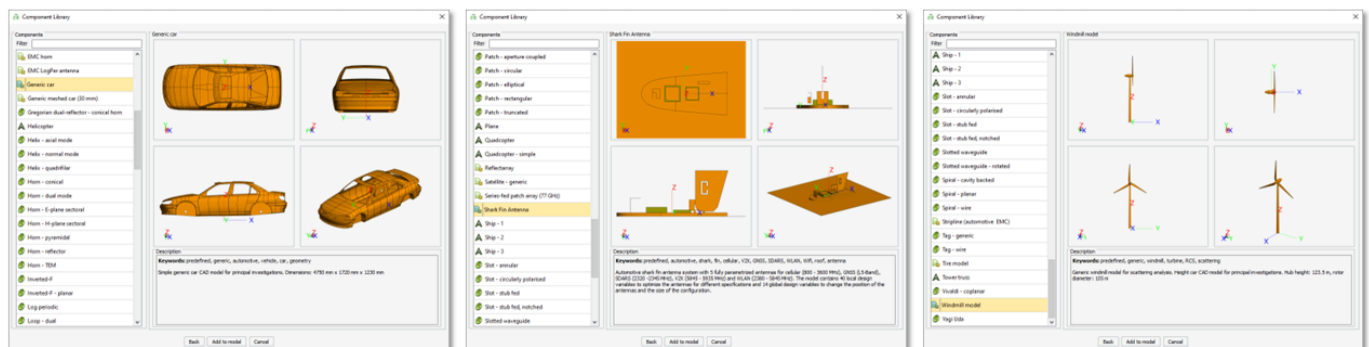

Figure 2: Three new components available in the Feko 2023.1 component library.

Salient Features in WinProp

- ProMan now supports 5G beam switching capability using a predefined set of beams. Users can now be served by a dedicated beam, with the possibility to transition to a different beam as they move.

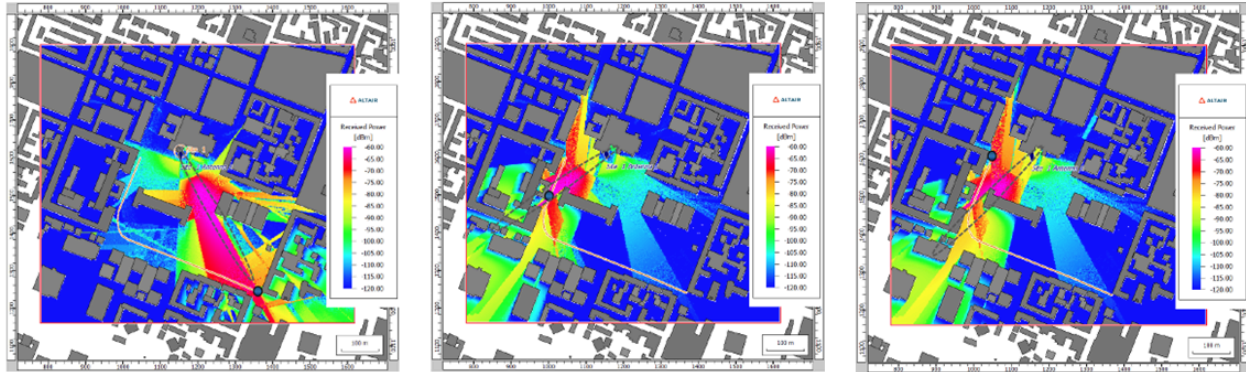

Figure 3: Left: Only the data beams that are serving a user are active (the best serving beam is selected). Centre: If the user moves, it switches to another predefined beam. Right: The serving beam is not necessarily oriented in the direct direction, it can for example, come from a reflection at the building.

- Added support in ProMan to display the total power from all transmitters in the tree under **Results: Propagation** if the **Superposed Received Power** check box was selected.

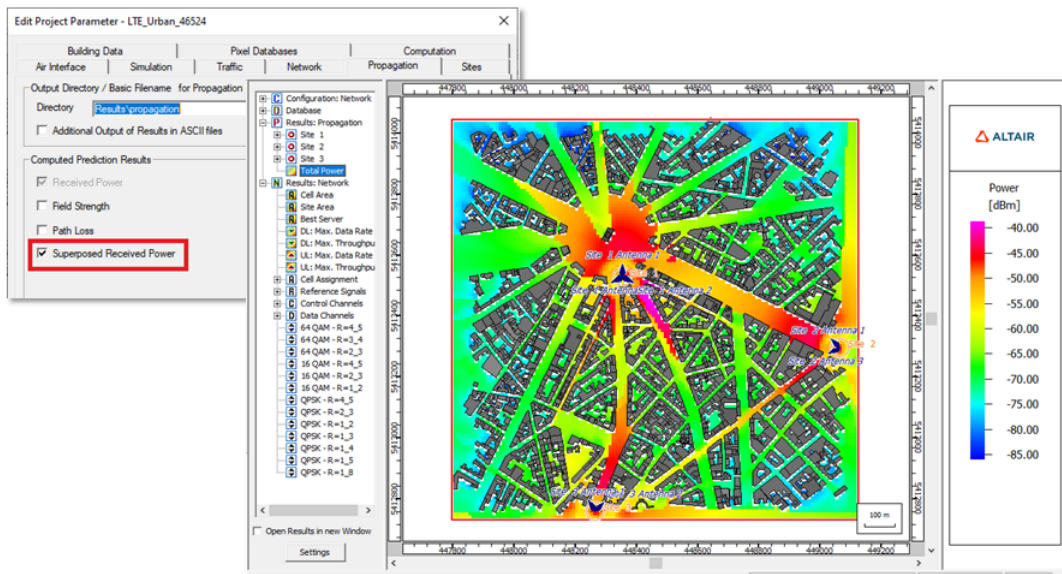

Figure 4: The total power is available in the tree if the option was enabled.

- ProMan was extended to define and display reference points on maps. These points are always visible on a map using an "X" sign (even if data is plotted). The names of points (prediction, user or reference points) can now be shown or hidden using the setting on the **Display Settings** dialog.

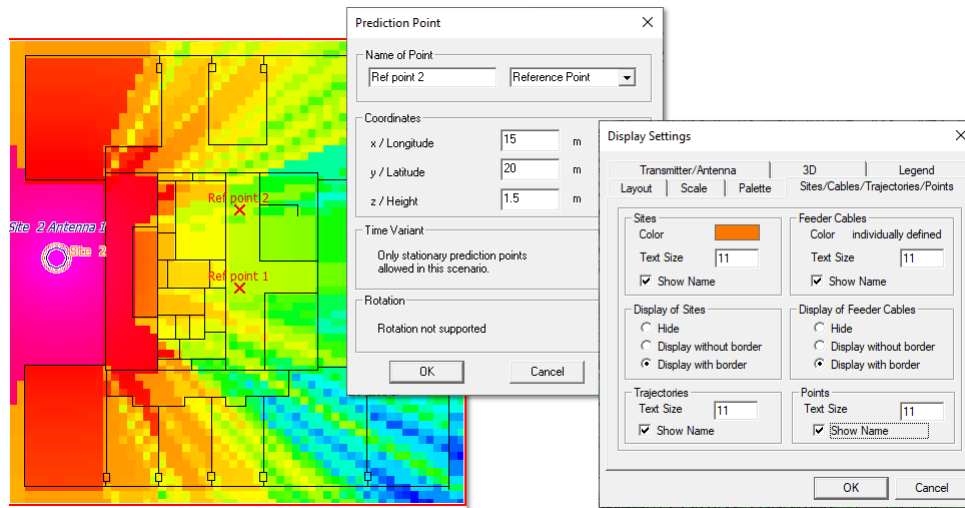

Figure 5: Reference points can be added to a map.

Salient Features in WRAP

- The ITU-R P.1812 propagation model was updated to recommendation ITU-R P.1812-6.
- The Clutter Loss Model was updated to recommendation ITU-R P.2108-1.
- Support was added to enter 5G parameters for calculations. The 5G parameters are used when calculating RSRP, RSSI, RSRQ, SINR, Data rate and Throughput.

Feko 2023.1 Release Notes

The most notable extensions and improvements to Feko are listed by component.

CADFEKO

Features

- Added functionality to reference grouped variables via their group name. Before it was required to give variables unique labels to ensure referencing the correct variable. It is now possible to distinguish between variables inside different groups and ungrouped variables, for example, *Var1*, *Group1.Var1* and *Group2.Var1*.
- Added the option to specify the transmit power to be used during the S-parameter calculation.
- Added the **Ensure continuous region representation** option to the Advanced tab of the **Voxel Mesh Settings** dialog. This setting controls whether a voxel mesh representation is created for a thin dielectric region which does not cut across multiple voxels.
- Extended cable schematics to support a distinction in concepts between local circuit device ground and global installation ground. This is achieved through the addition of new symbols for "Device ground" and "Installation ground".
- The ECAD import library used by CADFEKO, has been upgraded to the latest version provided by Altair PolEx.
- Gerber files (274X or 274D format) can be imported.
- Meshes can be exported to the Gerber file format.
- Feko's combined MoM/MTL cable solution method was extended to allow for the outermost shield signal of different paths in the harness to be connected via a shielded conductive enclosure defined in the full wave model. Inner circuit connections between different cable path signals bounded by the enclosure are now supported. Full coupling is supported between the cable harness, enclosure and the environment.
- Added the **Show mesh configuration details** checkbox to the advanced tab of the **Modify Mesh Settings** dialog. This option, when enabled, reveals some of the calculated values used for meshing.
- Improved the display of selected items (geometry and mesh parts and entities) in the 3D view.
- Added new visibility options. **Show** and **Hide** are available in addition to the existing visibility options such as toggling the visibility. All visibility options are grouped together inside the **Visibility** sub-menu on the right-click context menu.
- Changes were made to colours used in the 3D view to aid model investigation. Edges and wires are now shown in a thicker blue instead of yellow from previous versions. Various styling improvements were made to make it easier to work with and find items in the 3D view.
- Improved the display of selected items to be opaque when using opacity. This highlights the selected item with the rest of the model being semi-transparent. The overlay is also automatically hidden when opacity is used, resulting in a cleaner and clearer display of the model.
- Added a generic windmill model to the component library.

- Added a generic car CAD model to the component library.
- Extended the model tree to indicate hidden items with grey text and a disabled first icon. If an item is not visible, but sub-items are visible, the icon is updated to indicate the partial visibility. For excluded items, all icons are disabled.
- Extended the PCB import dialog with a netlist filter that enables to the user to specify specific nets to be imported.
- Added checks to ensure that schematic circuit connections take preference over mesh connections in combined MoM/MTL cable harnesses.
- Added the option to **Preserve all entities** for global and local mesh settings. This option is used to retain an entity after meshing. Tiny edges in the model, that would otherwise be collapsed, can be retained by enabling this option.
- Updated the layout of the S-parameters dialog.
- Added an additional **Simplify** option to the **Spin** operator. With this option enabled, redundant vertices and edges are removed as a final step in the creation of the spun geometry. This simplification was performed by default when creating spun geometry in the original 2023 release, but had to be removed since it was not available in CADFEKO [LEGACY] and caused issues for the conversion of legacy models.
- Added a model of a parameterised automotive shark fin antenna system (Cellular, GNSS, SDARS, V2X, WLAN) to the component library.

Resolved Issues

- Improved usability by reviewing and updating visibility and visualisation features.
- Fixed a bug where replacing parts in sub-trees did not perform the correct mapping. The incorrect mapping could result in strange behaviour such as **Show All** having no effect on the items.
- Corrected an issue with the cable schematic view where the view resized and connectors were placed on top of each other when adding a cable connector.
- New CADFEKO now theoretically supports saving and loading model file sizes up to 9 Exabytes. Previous models were limited to a maximum of 2 Gigabytes or less, depending on model complexity.
- Resolved an issue that prevented importing a CADFEKO model containing references to variables inside groups and using a prefix during import. Depending on the version, either a `Variable not found` error was issued or an assertion failed when attempting to import a model with grouped variables.
- Resolved an issue with the schematic view not opening with the same view (zoom level and position) as at the time of saving the model.
- Resolved an issue with a sudden change in the schematic view after loading a model and panning or zooming the schematic view.
- Improved mapping of edges when using the sweep and the path sweep operator or any operation that derives entities from other entity types (a vertex being the source of an edge or an edge being the source of a face or a face being the source of a region). This change causes edges to have different labels, but is an improvement (correction).
- Resolved an issue where grouped variables did not show on the **Modify variables** dialog. Variables inside groups can now be modified on this dialog and variables can be moved between existing variable groups.

- Improved meshing of tightly coiled helix structures when using the new default mesher in CADFEKO. Invalid meshes may still be encountered when switching to the legacy mesher or when using CADFEKO [LEGACY].
- Fixed the loading performance of models where a large number of model verification warning or error messages get issued.
- Resolved a crash that could be encountered when working with a model containing cable ports that are not associated with a cable harness. It was possible to create a model like this in older versions of CADFEKO where cable ports were not deleted when the cable harness that they referenced was deleted. Any cable ports that are not associated with a cable harness are now deleted from a model when it gets loaded.
- Improved internal CAD model structures to reduce memory usage and file size and to improve performance.
- Added verification that an edge mesh port cannot bound a FEM region.
- Resolved an issue with the Show/Hide functionality where showing a port on hidden geometry resulted in all other geometry being hidden in the 3D view.

EDITFEKO

Features

- Added the schematic link (SL) card for defining the interface between cable schematic elements and 3D geometry.
- Added an option to the SP card to specify the transmit power to be used during S-parameter calculation.
- Updated text on the AK, CI and LC cards to distinguish between device ground and installation ground pins.
- Added a new cable harness (CH) card to group harness specific parameters.
- Extended the CS card to allow for the definition of a connection to the device ground at the start or end of a cable path section in combined MoM/MTL cable harnesses.

POSTFEKO

Resolved Issue

- Corrected the positioning and sizing of graphs with PDF report generation.

Solver

Features

- Upgraded Qt and OpenSSL to the latest versions.
- Support S-parameter calculations at a user-defined transmit power level.

- Updated Intel MKL to version 2023.2.
- CMA support for generalised impedance boundary conditions (GIBC) applied on the boundaries of SEP regions.
- Improved accuracy of the characteristic mode analysis for impedance boundaries in the free space, port loads and networks.
- Added support for CMA simulations with the CFIE.
- Added support double edge and wedge diffraction with Faceted UTD. Ray paths between sources and observers can now concatenate two single diffractions at physical edges and wedges. Consideration of this effect requires "Edge and wedge diffraction" and "Higher-order effects" to be enabled and a maximum number of interactions larger than or equal to two.
- Significantly increased faceted UTD simulation speed over discrete frequency bands by reusing calculated rays.
- Support Physical Optics integration to compute the radiation from equivalent sources using RL-GO with high accuracy setting. It improves the accuracy of the solver by considering the phase variation of the equivalent current across the ray footprints on the geometry.
- Extended the multiport processor to support scaling of near field data.
- Reduce the memory footprint for the parallel MPI direct sparse FEM solver of more than hundred thousand unknowns by using some MPI processes as threads during the sparse LU factorization and solve phases.
- The combined MoM/MTL method was extended to support additional configurations when connecting cable path end points and the MoM mesh. As an example, pigtail-type connections can now be accurately represented. Configuring these connections is not trivial, and this will be addressed in future updates.
- Upgraded MUMPS to version 5.6.2altair.
- The performance of hybrid FEM/MoM simulations involving multiple excitations (for example a solution with plane-wave incidence angles or a multiport S-Parameter calculation) is improved by avoiding re-computation of matrices where it is not necessary.
- The MTL solution method was extended to support a distinction in concepts local circuit device ground and global installation ground. Circuit connections between harness signals and a nearby local device ground is considered non-radiating. The net current through elements connected between the device ground and the installation will be added as impressed currents to the radiating solution. For combined MoM/MTL harnesses the device ground indicates the transitioning point from circuit to full wave solver. Connections beyond the device ground should be included in the full wave model.
- Accelerated loss calculations over segments, triangles, VEP cuboids and VEP tetrahedra by parallelizing the relevant routines.
- Improved the speed of computation of spherical modes for multi-processor simulations.
- Improved parallel process memory scaling when using the direct FEM sparse solver for a hybrid FEM/MoM solution.

Resolved Issues

- Implemented validation for model mesh labels to ensure compatibility with solvers.

- In combined MoM/MTL harnesses schematic circuit connections now take preference over mesh connections. This results in the setup of an improved full wave model.
- Resolved a bug in no results being computed in standard configurations defined after a CMA configuration.
- Improved the management of far-field interactions for MLFMM algorithm for models with very high losses to avoid errors during the iterative solution.
- Corrected excessive memory consumption and potential crash when running large ACA simulations over multiple nodes.
- Avoid internal error 32488 when using both CFIE and EFIE in a solution involving CBFM and MLFMM.
- Corrected errors with adaptive cross-approximation (ACA) solutions including multilayer planar dielectrics and using threads.

Shared Interface Changes

Features

- Renamed **Orbit/Satimo (*.mfxml) measurement file** to **MVG (*.mfxml) measurement file** in CADFEKO and EDITFEKO.
- Increased the `.fek` file version to 192 to accommodate new features.
- Updated the multiport combinations configuration file format to include information on the spatial positions of ports.

Support Components

Features

- The CADFEKO [LEGACY] graphical user interface component is in the process of being phased out and is no longer included in the main Feko installation. It is available as a separate installation for users who need to continue using the CADFEKO [LEGACY] graphical user interface while the new interface gets rounded off based on feedback received.
- Removed the functionality to launch CADFEKO [LEGACY] from the Launcher utility. The CADFEKO [LEGACY] interface can still be installed alongside the Feko installation and launched directly from the installed location.
- Added the **Create Edge Port for Finite Substrate** macro that creates an edge port on a finite substrate. The macro removes a small cuboidal section and creates a PEC "bow-tie" structure. An edge port is then added to the centre edge of the "bow-tie" structure. This macro simplifies the process of adding an edge port to a finite substrate since a port cannot be placed on the boundary of a finite dielectric substrate when using the method of moments (MoM).

WinProp 2023.1 Release Notes

The most notable extensions and improvements to WinProp are listed by component.

General

Feature

- Updated Intel MKL to version 2023.2.

ProMan

Features

- Added support to specify and display reference points on maps. The points are defined on the **Prediction Point** dialog and are always visible on a map (even if data is plotted) using an "X" sign. Added support to show/hide the names of points (for example, prediction, user or reference points) on the **Display Settings** dialog.
- Improved the loading time of predictions in the vertical plane.
- Added support for 5G beam switching capability using a predefined set of beams. Users can now be served by a dedicated beam, with the possibility to transition to a different beam as they move.
- Extended urban empirical models to include ray intersections with vegetation.
- Changed the minimum reflection angle to 0.1 deg, before it was 1 deg.
- The total power from all transmitters together can now be displayed (optional) after a regular propagation simulation.

Resolved Issues

- Resolved an issue for the SBR/SRT where rays were incorrectly discarded while checking for line-of-sight.
- Resolved an issue for the SBR where rays were discarded due to incorrect path loss estimation.
- Fixed a problem where the transmission loss was computed incorrectly for empirical losses.

newFASANT 2023.1 Release Notes

The most notable extensions and improvements to newFASANT are listed by component.

GUI

Resolved Issues

- Various improvements have been made to the image rendering and the shading of the 3D view has been adjusted.

Solver

Feature

- Updated Intel MKL to version 2023.2.

WRAP 2023.1 Release Notes

The most notable extensions and improvements to WRAP are listed by component.

General

Features

- Updated WRAP equipment databases to version 173.
- Moved the import and export to the same menu as other area formats.
- WRAP will not open API sockets by default. The user needs a valid API license and the license feature **SolverHPC** and **OpenAPISocket** element should be enabled in the WRAP settings file `WRAPSettings.ini`.
- Altair license feature "SolverHPC" is required to use Socket communication API functionality in WRAP.
- A new function was added in ObsMan to allow the exclusion of existing cases from calculations.
- The colour of the obstacles shown in the map are now different depending upon the obstacle origin and status.
- Added the option to limit the number of created wind turbines in an ObsMan wind turbine farm.
- Added ability to show obstacles from FIA and ObsMan simultaneously. Shown obstacles stays with their selection per ObsMan tab page.
- Made the following dialogs resizable in map viewer: **Open Area** dialog and **Delete Area** dialog. Made the following dialogs resizable in Obstruction Manager: main window, **Select case** dialog, **Method 2 settings** dialog, **Detailed Calculation Results** dialog, **Detailed link result** dialog, **Radar types** dialog and **Create obstacle farm** dialog.
- Propagation model ITU-R P.1812 has been updated according to ITU recommendation ITU-R P.1812-6.
- Updated the clutter loss model according to recommendation ITU-R P.2108-1.
- Added Example 2.6 to WRAP Example Guide. It shows how to perform LTE Specific Coverage Calculations, considering parameters like RSRP and Data Rate, effects of MIMO, and using recently introduced post-processing features.
- Updated Example 15.2 in WRAP Example Guide that guides the user on how to integrate population data in WRAP and use Cost and Coverage Optimizer for population-based coverage calculations.
- Added support to enter 5G parameters for calculations. RSRP, RSSI, RSRQ, SINR, Data rate and Throughput were extended to use the 5G parameters during the calculation.
- The FIA database can now be updated from a text file in addition to the DAIM format.

Resolved Issues

- Corrected the crop function in the WRAP MapDataManager for use with the new index file format.
- Corrected the WRAP MapDataManager GRIDASCII export function.

Release Notes: Altair Feko 2023.0.2

Altair Feko 2023.0.2 is available with new features, corrections and improvements. This version (2023.0.2) is a patch release that should be applied to an existing 2023 installation.

This chapter covers the following:

- [Feko 2023.0.2 Release Notes](#) (p. 22)
- [WinProp 2023.0.2 Release Notes](#) (p. 25)
- [WRAP 2023.0.2 Release Notes](#) (p. 27)

Feko is a powerful and comprehensive 3D simulation package intended for the analysis of a wide range of electromagnetic radiation and scattering problems. Applications include antenna design, antenna placement, microstrip antennas and circuits, dielectric media, scattering analysis, electromagnetic compatibility studies including cable harness modelling and many more.

newFASANT complements Altair's high frequency electromagnetic software tool (Altair Feko) for general 3D EM field calculations, including, among others, special design tools tailored for specific applications like complex radomes including FSS, automated design of reflectarrays and ultra-conformed reflector antennas, analysis of Doppler effects, ultrasound systems including automotive or complex RCS, and antenna placement problems. Advanced solver technologies like the MoM combined with the characteristic basis functions (CBFS), PO/GO/PTD, GTD/PO and MLFMM parallelised through MPI/OpenMP, being some of them especially efficient for the analysis of electrically very large problems.

WinProp is the most complete suite of tools in the domain of wireless propagation and radio network planning. With applications ranging from satellite to terrestrial, from rural via urban to indoor radio links, WinProp's innovative wave propagation models combine accuracy with short computation times.

WRAP is a comprehensive tool for electromagnetic propagation, antenna collocation and spectrum management. WRAP combines propagation analysis, often over large areas with many transmitters and receivers, with system analysis to include complex non-linear equipment properties.

Feko 2023.0.2 Release Notes

The most notable extensions and improvements to Feko are listed by component.

CADFEKO

Resolved Issues

- Model status verification will only indicate `Error 19956: Dielectric faces may not be located on the interface of the planar Green's function` when the error is relevant.
- Fixed voxel meshing failures for specific models, especially at higher frequencies.
- Resolved an issue where ports went missing when converting a part to primitive. Ports that were placed on geometry parts deeper than three levels inside the root geometry were erroneously being removed when converting the outer level part to primitive.
- Prevented an assertion failure when loading a legacy model containing faulty parts. The model can now be opened and an error message in the model status window indicates which parts are problematic.
- Fixed a crash when modifying the cross section of a cable instance to a new cross section with fewer signals.
- A failed deletion of cable connectors and schematic components will not result in duplicated 'ghost' symbols on the schematic.
- Resolved a crash during legacy conversion for a model with overlapping terminals and nets.
- Resolved an issue where the `.pre` file writing of SD cards omitted the transfer admittance definition of a cable shield. The solver could terminate with `ERROR 52750: Define shield properties: expecting an impedance and/or admittance specification` when running a model where the cable shield transfer admittance definition was set to reference an external XML file.
- When saving a model, the saved state indicator (*) was not correctly cleared after saving completed.
- Resolved a crash when undoing a sweep or spin operation on geometry.
- Improved handling of faulty parts for CAD models. This speeds up load time.
- Resolved an issue where the project filter was not correctly filtering faces with default medium set.
- Fixed an issue where the modification of a geometry part did not take effect if the part was previously deleted and reinstated using the undo operation.
- Added a minimise button to the **Executing runfeko** dialog.
- Improved the modify variables tool to allow editing of **Minimum** and **Maximum** values while **Limiting** is unchecked.
- Resolved an issue where the **Polyline** and **Polygon** dialogs could sometimes get into a strange state when clicking **Add**. This strange state resulted in crashes.
- Updated the verification message that gets issued when a cable harness solved with the multiconductor transmission line (MTL) solution method intersects with a conducting surface or a PEC ground plane. Previously, the same error message was issued as for the case where the distance from the conducting surface or ground plane is too large.

- Resolved an issue where there was no icon in the tree indicating if local mesh settings were applied to primitive geometry parts.
- Improved legacy CADFEKO model conversion for models where the normal direction of selected faces was reversed in earlier versions. Before this change, such models may have failed to convert to the latest CADFEKO format.
- Resolved a crash when invalid signal connections were applied on the **Create Cable Instance** dialog.
- The **Windows Security Alert** firewall exception dialog is no longer shown when opening the **Altair Material Data Center**.
- Resolved an issue where FEM ports could not be created for meshes if there were only FEM meshes in the model.
- Symmetric verification for face normals is no longer checked when the face medium is set to perfect electric conductor, dielectric boundary or default.
- Fixed a crash after loading overlapping frequency bands from the model in the **Create Frequency Ranges** application macro.

POSTFEKO

Resolved Issue

- Resolved an issue with near field exports where local coordinate axes would not be written out to `.efe` and `.hfe` file for near fields in the global coordinate system with only an offset specified.

Shared Interface Changes

Resolved Issues

- The complete simulation output is correctly shown in the execution dialog during AMRFEKO runs.
- The complete simulation output is correctly displayed on the console during an AMRFEKO run.

Support Components

Features

- During AMRFEKO runs, error estimates will not be written to the out file by default so that large out files are avoided.
- The temporary files created by AMRFEKO now include “_amr_” in the name for easy identification.

Resolved Issues

- During an AMRFEKO run, the number of completed and remaining solutions is correctly reflected in the standard output.
- The standard output of AMRFEKO does not include duplicate linefeeds/newlines.

- Transformed geometry (TG card) is correctly managed during the execution of an AMRFEKO run.
- Corrected the command line parsing so that --keep-files can be used with AMRFEKO and other utilities such as ADAPTFEKO.

WinProp 2023.0.2 Release Notes

The most notable extensions and improvements to WinProp are listed by component.

General

Feature

- Resolved an error that occurred when converting a `.tub` database to `.ida` or `.idb` file format.

Resolved Issue

- A more coarse resolution from the **Elevation Profile** dialog when exporting a tunnel topo to `.idb` file is only suggested when the area covers more than 10 million pixels.

ProMan

Feature

- Relaxed the condition for the monostatic RCS consideration so that all pixels in the direction back to the transmitter are computed.

Resolved Issues

- Resolved an issue where a log file (`WinPropLogfile.txt`) was written out for urban computations when a warning was encountered.
- The conditions for the calibration of the wave propagation models (DPM, IRT, SRT) are now checked before the computation.
- Resolved an issue where projects containing area wide and prediction planes, the status bar showed "N.C." for area result values.
- Fixed a bug for the urban IRT where the reflection point was at $z=0$ instead of the correct tile center location.
- Resolved an issue where only the first Rx height was computed and displayed for rural projects based on geodetic coordinates. This was corrected, and multiple Rx heights can now be computed and displayed.
- Resolved an issue where the computation of a project using SBR resulted in a long runtime due to freeing memory.
- Fixed a bug where, for very small resolution, no prediction plane was created for the repeater, which resulted in the repeater contribution being missing in the network planning result.
- Resolved an error for network planning if the MS results were saved in individual sub-folders that can be configured under **Settings > Global Settings (Directories, Display)**.
- The palette for the display of computed results is now correctly loaded and saved in the `.wpi` file.
- Resolved an issue where higher computation time was observed when compared with previous releases.

- Resolved an issue with the Urban Knife Edge model where the wrong coordinates were used during propagation for point prediction at absolute height.

WRAP 2023.0.2 Release Notes

The most notable extensions and improvements to WRAP are listed by component.

General

Feature

- Statistical results in coverage that decreases with distance, for example, Field strength and Received Power, are sorted in reverse order to align with the coverage information page on the **Edit result** dialog.

Resolved Issues

- Resolved an issue where the full power from the base station is now used in the SINR calculation instead of the reduced power when the cell load is less than 100%.
- On the **Separation Distance** dialog, enable the **Calculate Distance** button with default settings by changing the default calculation mode to area mode for the default propagation model (Longley-Rice).

Release Notes: Altair Feko 2023.0.1

3

Altair Feko 2023.0.1 is available with new features, corrections and improvements. This version (2023.0.1) is a patch release that should be applied to an existing 2023 installation.

This chapter covers the following:

- [Feko 2023.0.1 Release Notes](#) (p. 29)
- [WinProp 2023.0.1 Release Notes](#) (p. 36)
- [WRAP 2023.0.1 Release Notes](#) (p. 38)

Feko is a powerful and comprehensive 3D simulation package intended for the analysis of a wide range of electromagnetic radiation and scattering problems. Applications include antenna design, antenna placement, microstrip antennas and circuits, dielectric media, scattering analysis, electromagnetic compatibility studies including cable harness modelling and many more.

newFASANT complements Altair's high frequency electromagnetic software tool (Altair Feko) for general 3D EM field calculations, including, among others, special design tools tailored for specific applications like complex radomes including FSS, automated design of reflectarrays and ultra-conformed reflector antennas, analysis of Doppler effects, ultrasound systems including automotive or complex RCS, and antenna placement problems. Advanced solver technologies like the MoM combined with the characteristic basis functions (CBFS), PO/GO/PTD, GTD/PO and MLFMM parallelised through MPI/OpenMP, being some of them especially efficient for the analysis of electrically very large problems.

WinProp is the most complete suite of tools in the domain of wireless propagation and radio network planning. With applications ranging from satellite to terrestrial, from rural via urban to indoor radio links, WinProp's innovative wave propagation models combine accuracy with short computation times.

WRAP is a comprehensive tool for electromagnetic propagation, antenna collocation and spectrum management. WRAP combines propagation analysis, often over large areas with many transmitters and receivers, with system analysis to include complex non-linear equipment properties.

Feko 2023.0.1 Release Notes

The most notable extensions and improvements to Feko are listed by component.

CADFEKO

Features

- Added quick entry of variables to fields on dialogs that support parametric expressions by snapping to variables in the model tree.
- Extended KBL cable harness importing to parse **Special_terminal_occurrence**, **Component_box_occurrence** and **Referenced_components** objects and made general improvements to KBL importing.
- Increased the size of the **Modify Variables** dialog. The dialog can now also be vertically resized.

Resolved Issues

- Fixed an issue with legacy model conversion that could result in cable connectors drawn with a different width than expected on the cable schematic view, causing incorrect or missing connections.
- Resolved an issue during legacy model conversion where the reference direction on a cable path could be reset if it was defined using expressions.
- Schematic items are now created as close as possible to the centre of the schematic view.
- Resolved an issue for schematic views where pressing Ctrl and holding down the left mouse button while hovering over a node entered wire creation mode instead of panning the view.
- Moved the **Rendering** group from the **View** tab to the **Display Options** 3D view contextual tab.
- Fixed a problem for schematic views where moving components connected to nets would create a spike in the net.
- Removed a verification error preventing regions using VEP and DSIA solution methods being solved when using CMA.
- Resolved an issue where face media properties were not considered for FDTD meshing.
- Fixed an issue with the conversion of adaptive frequency sampling settings in legacy CADFEKO models. The **Transmission / reflection coefficients** and **Non-radiating networks and loads** quantities were incorrectly transferred to new CADFEKO.
- Resolved a hang that could occur when automatically meshing geometry from large Parasolid imports.
- Fixed an assertion failure when unlinking the mesh of symmetric wires with ports on the symmetry plane.
- Resolved a crash when undoing a change that required the model to be re-meshed due to other parts being in close proximity to the part that was changed.
- Resolved a rare crash when rendering a model with a very large mesh.
- Remove a cable port when its associated cable harness is deleted to avoid a crash.
- Fixed a problem where an empty `.pre` file was written out after loading a legacy `.cfx` file.

- Resolved an issue with the `.cfm` file writing of symmetric wires that could result in `Error 16: Undefined wire port segment` when running the solver.
- Added a warning that will be issued when the file size of the model approaches the upper limit which can be saved.
- Fixed a crash when selecting edges while creating a microstrip port.
- Resolved an issue with SK card writing to `.pre` file where SK cards were not always written out for wires with ports on them. If a wire has a port, it will now always write an SK card for the port. An SK card for the wire will only be written in addition to the SK card for the port if there is more than one segment in the mesh for the wire.
- Fixed an issue where CI cards were not written out correctly to `.pre` file for shielded cable instances with direct connections between cable connectors on the schematic view.
- Added a check for a valid FEKO_TMPDIR to use for temporary files. The application will attempt to create a folder if it does not exist. If a process like geometry import fails due to the temporary folder being inaccessible, an appropriate error is issued.
- Added show/hide functionality to cable harnesses.
- Fixed a bug that hiding a cable connector would shift items on the cable schematic.
- Resolved a crash upon opening the mesh info dialog in version 2023 when there is no simulation mesh to report on.
- Loading large legacy models should no longer result in an assertion failing with `xtgraphics` error messages. This is a regression that got introduced in Feko 2022.2.2. The assertion failure was triggered in the last step of the conversion when the view was being zoomed to extents. A workaround for this bug is to convert the model first using the legacy CFX converter application before loading it into CADFEKO.
- Performance is now significantly improved for models that have many requests, source loads or parametric geometry that use variables. Model loading speed and 3D view interactions have seen up to a factor of three times improvement when variables are used extensively. Furthermore, rendering of near field requests is now faster.
- Improved entity auto-labelling to be more consistent with CADFEKO [LEGACY] . Some macro recorded scripts may need adjustments since the labels may have changed.
- Resolved an intermittent assertion failure when using the **Parameter Sweep: Create Models** application macro.
- Fixed an issue where a schematic net would change shape when moved within a larger selection.
- Improved the schematic view interaction performance.
- Fixed a crash when moving items on the schematic view if the current selection of items also contains items that are not on the schematic view.
- Prevent creating duplicate triangles in the simulation mesh when symmetry is enabled.
- Fixed a possible crash when modifying ports containing lists of geometry references.
- Resolved an issue where the mesh would be hidden when the mesh info dialog was open.
- Resolved an issue where closing the application while the model was being validated could result in a crash.
- Resolved an issue where the `.pre` file writing of SD cards did not reflect that the transfer impedance of a cable shield was to be loaded from a file. The solver terminated with `ERROR 52750:`

Define shield properties: expecting an impedance and/or admittance specification when running a model where the cable shield transfer impedance definition referenced an XML file.

- Greatly improved rectangle selection performance when multiple items are selected.
- Corrected legacy model conversion of FEM line ports when a custom default workplane was set. The line port would use the default workplane instead of the correct **Global XY** workplane.
- Corrected waveguide port validation on model mesh faces. The model status window could have incorrectly indicated that the port reference vector does not align with one of the rectangular waveguide edges.
- Resolved an assertion failure when opening the mesh info dialog if the model contains only wire segments.
- Prevent deleting boundary triangles, for example the boundary triangles of a tetrahedral region.
- Resolved a crash when deleting triangles from transformed model meshes.
- Fixed a problem where waveguide ports and sources would cause `.pre` file writing to fail.
- Improved meshing for models that contain extremely small edges that should rather be ignored. Previously it would over-refine in these areas.
- Improved the calculation for the start and end points of microstrip ports.
- Improved the handling of symmetrical elements crossing the symmetry plane by ensuring that they are written out perfectly symmetrical to avoid an error in the solver.
- Resolved an issue with model status errors not being issued for grouped geometry or meshes that are not symmetric around the symmetry planes.
- Improved the conversion of legacy CADFEKO models where different types of schematic components have identical labels.
- Added validation to the prefix field when importing a CADFEKO model. Previously an assertion failed upon import if the prefix label contained invalid characters.
- Improved tolerance handling with respect to `.pre` file writing for models employing symmetry.
- Corrected the criteria for the verification of dielectric sheet layer magnetic properties. The check is ignored when the face bounds SEP regions, is compared against free space when the face bounds VEP regions and compares against front and back medium when bounding FEM regions.
- Avoid creating metallic triangles on the symmetry plane when symmetry is enabled.
- Fixed symmetry verification messages to only show root level geometry and not nested geometry as well.
- Symmetrical mesh entities using a scale transform will be correctly identified as symmetric.
- Fixed macro recording for transforms.
- Removed memory leaks during an optimisation run by greatly improving the memory usage of the launcher dialog and external process executor.
- Fixed an assertion failure when trying to add a solution coefficient source to a model containing locally defined sources and multiple configurations.
- Models that require an internal mesh element size larger than 100 could have over-refined and possibly caused the mesher to run out of memory. This was seen mostly with model mesh parts that were scaled and even though the mesh size was smaller than 100, the scaled mesh size was larger than 100 and caused the problem.
- Fixed an issue causing additional refinement in the mesh when symmetry is enabled.

- Fixed an assertion failure when closing a model with variables referenced in the mesh settings.
- Resolved an issue where SK cards were incorrectly written out to `.pre` file and the solver failed with the error `No triangles/segments found with the correct label to apply the skin effect approximation for valid models`.
- Fixed script recording that sometimes missed setting values when adding entities.
- Fixed an issue with view anchoring selecting model mesh behind a geometry part.
- Improved mapping of edges when using the sweep and the path sweep operator. This change causes edges to have different labels, but is an improvement (correction).
- Updated CADFEKO `.pre` file writing to write to the EG card a maximum identical distance that depends on the size of the model. In the past it would always use `1e-6` as the default. This solves problems for small and large models where the elements became too small or too large relative to the maximum identical distance.
- Changed the spin operator in the new CADFEKO to work like it did in CADFEKO [LEGACY] by no longer automatically removing redundant edges. This solves problems with loading legacy models.
- Improved curved edge symmetry calculation.
- Fixed the progress indicator not completing when other Feko components like PREFEKO and RUNFEKO have finished running.
- Made general and simulation mesh related memory improvements.
- Resolved an assertion failure with drag and drop for combined geometry containing nested groups.
- Resolved an issue where the script editor would not maintain the location of previously saved or opened scripts.
- Resolved an error being issued after a successful geometry import if there is no 3D view.
- CADFEKO model (`.cfx` file) importing will now zoom to extents after a valid import to show the entire model in the 3D view.
- Made improvements to the legacy model converter for labelling and grouping of elements that fail to convert or struggle to match with an element in a legacy model.
- A number of corrections were made to the simplify operator. In some cases, edges, faces and redundant points were not removed when they were supposed to be removed.
- Fixed missing reference vector fields when setting the medium to characterised surface on the mesh properties dialog.
- Named points and variables can now be used to modify a mesh vertex. The vertex will not keep a reference to the symbol once modified.
- Fixed a circular reference exception when a named point attempts to reference itself. An error message indicates when a named point definition contains a circular reference.
- Fixed a crash when using nil or empty expressions in Lua scripts when calling a method.
- Improved 3D view anchoring to rotate around topology under the cursor when the rectangle selection method is in use. If nothing is under the cursor, rotation will still be around the centre of the view.
- New options and improvements to the project tree filter can greatly improve the filtering performance. The label filter also now supports exact, in addition to partial, filtering.
- Prevented the operators on excluded topology as it would result in scenarios where the topology could not be included again.

- Corrected the `.pre` file writing for error estimates that use label scopes, in other words, error estimates that are set up to calculate on elements with a set of labels.
- Fixed an issue where mesh ports were not being rendered in the correct position when transforms were applied.
- Measurement tools can now reference variables and named points.
- Resolved an assertion failure when grouping combinations of groups and other topology.
- Improved 3D view anchoring for rotations around ports. Now the centre of rotation will anchor to ports when under the cursor instead of using the centre of the view.
- Resolved a model status error that was incorrectly issued for correctly defined 3D anisotropic media by adding a machine precision tolerance.
- Fixed the display of mirrored model mesh face normals.
- Resolved an issue with the keyboard shortcut (R) not working to rotate elements on the schematic view.
- Fixed a legacy conversion issue that the schematic projection and connector spacing values were not transferred to the new model.
- Fixed visibility for FEM line ports defined using points.
- Changed the default scale value for an optimisation goal from zero to one.
- Fixed a case where a model with locked parts could not be loaded.
- Fixed a model tree visualisation bug where the simulation mesh icon was displayed for geometry children of unmeshed combined geometry inside of a group. Combined geometry refers to geometry created with Boolean operators such as subtract.
- Operators that combine geometry will now create the resulting geometry where the geometry being combined reside. As an example, a union of two parts in a group will create the union in the group.
- Removed a verification warning for looped plane waves with CMA.
- Local sources and loads on ports are only displayed in the 3D view for the active configuration.
- Relaxed the tolerance and increased the number of entities considered as potential symmetric entities to improve the accuracy of finding a valid symmetric partner.
- Resolved an incorrect error when using the fill hole tool.
- Prevent setting locked or included status on child geometry via scripting.
- Added the lock action to the **Transform** tab on the ribbon.
- Converting a combined geometry with nested groups into a group will move the nested groups into the newly created group.
- 3D view anchoring for rotation now ignores rendering of requests so that rotation will centre around topology under the cursor instead of the centre of the view.
- Fixed certain instances where the initial mesh for a locked geometry part was not generated.
- Resolved an issue where the application appeared to hang when opening the mesh info dialog during meshing. If a mesh is not available, the line edits will indicate zero and if meshing is happening in the background, the fields will indicate **Updating....**
- Resolved an issue where a UTD plate with defined symmetry resulted in a solver error.
- Added validation when trying to modify locked entities. Actions that cannot be performed on locked entities are disabled.

- Ensured legacy CADFEKO model conversion transfers the locked status of entities correctly.
- Added a progress bar when creating the models in non-interactive mode for the **Parameter Sweep>Create Models** application macro.
- Improved the bounding box calculation for segment voltage sources on ports at the start and end of a wire. Before this correction FDTD validation could incorrectly fail for a valid model.

EDITFEKO

Resolved Issues

- Resolved an issue when opening an AW card from an older model, it did not have the **Use legacy magnitude convention** option checked.
- Resolved an incorrect error that was issued when editing the CD card if the radius of a twisted pair cable was larger than 1.
- Fixed the RA card file browser to filter on the correct file extensions for Orbit/Satimo format.

POSTFEKO

Features

- Extended the **Optimise Model in HyperStudy** application macro to support HyperStudy on Linux.
- Extended the **Calculate Mixed Mode S-Parameters** application macro to export the mixed mode S-parameters results to Touchstone version 1 files.

Resolved Issues

- Resolved assertion failures that could have occurred when using the POSTFEKO **Calculate Mixed Mode S-Parameters** application macro.
- Resolved a regression that got introduced in version 2022.3 where manual grid range settings were not being respected on Cartesian graphs when zooming to extents.
- Corrected the display of mesh faces set to be coloured by element normal.
- Fixed an assertion failure that was triggered when loading far field receiving antenna results from a `.bof` file only (no `.fek` file available) and selecting the result in the tree.

Solver

Features

- Improved the CMA treatment for lossless and lossy SEP cases so that performance for lossless calculations is comparable to earlier versions of Feko .
- Improvements were made to the faceted UTD, improving the identification of diffracted and reflected ray paths.

- The correct value for the CBFM threshold is written to the out file and the default MLFMM + CBFM block size is adjusted to appropriate values for CFIE and EFIE based solutions in order to improve general accuracy and maintain generally good convergence of the iterative solution across a number of problems.
- The accuracy of the CBFM for problems where there are sources close to the geometry has been improved.

Resolved Issues

- Improved spacing in the header line of the ray file.
- Improved ray tracing for faceted UTD to identify ray contributions that may have been missed for some cases.
- Avoided an error when tetrahedral near field requested without any tetrahedra in the model. A warning will now be issued for this case.
- Improved faceted UTD runtime for results that require multiple interactions.
- Fixed a segmentation violation when running CBFM with MLFMM.
- Corrected the interpretation of phase information included in equivalent near field aperture source and/or receiving antenna definitions for coupling simulations, thereby improving accuracy for Cartesian boundary formats.
- Fixed a bug in the calculation of the normal vectors to the aperture faces of a Cartesian boundary near field receiving antenna. A consistent outward normal should be used.
- Improved error reporting when too many parallel processes are used for the distributed FEM preconditioner or direct sparse solver.

Shared Interface Changes

Resolved Issue

- Improved failure avoidance during startup due to application macros. A warning is displayed to the user if the application macro library extraction fails. Before, if the archive containing the shipped application macros could not be found and successfully extracted, application startup would fail silently.

Support Components

Feature

- Added an FAQ topic in the Feko User Guide that lists the solution methods that support GPU acceleration.

Resolved Issue

- AMRFEKO will now correctly stop when it is stopped from the run dialog in the GUI applications.

WinProp 2023.0.1 Release Notes

The most notable extensions and improvements to WinProp are listed by component.

General

Resolved Issues

- Corrected a problem where certain dialogs could not be resized in AMan (**Convert File** dialog) and WallMan (**AutoCAD Export** dialog, **Database Save As** dialog, **Import Database** dialog and **Material Import** dialog).
- Fixed a problem for the urban IRT preprocessing, to limit the prediction to the preprocessed area.

ProMan

Features

- Added an angular tolerance for the ground reflection of the rural ray tracing (RRT) to get a ground-reflected contribution in case of no specular reflection.
- Updated the text on the **Parameter: Standard Ray Tracing (SRT)** dialog to indicate that scattering is also included in the specified limit **Max reflections and diffractions**.
- The **Propagation phenomena** group is now greyed out in ProMan for urban projects on the **Material Properties** dialog. In case of 0 roughness, scattered rays are no longer computed for the urban IRT, which happened in previous versions by mistake.
- Dynamic range for difference plots has been adapted to show more details.
- Propagation results can now be converted to dBW/m² and the x-axis of 1D line plots can be converted from metres to nautical miles.
- Enhanced the coordinate transformation capabilities by adding the UTM to Geodetic conversion option and by allowing to copy the converted coordinates.

Resolved Issues

- Improved the accuracy of the parabolic equation solver in regions of the topography where the slope is too steep.
- Resolved a bug in the computation of transmission matrix element computations for predictions where only the direct ray is considered.
- Corrected a problem where the leaky feeder cable was not displayed in the 2D or 3D view.
- Several improvements for transparent repeaters were made, including higher default amplifier gain, setting the signal group ID of the gateway to avoid interference, consideration of repeater results in RunMS.
- Resolved an issue for the rural ray tracing (RRT) propagation model where the number of standard ray tracing (SRT) interactions on 3D objects was not correct.

- Resolved an issue where the ground reflection for a transmitter outside the preprocessed map was not computed.
- Resolved an issue with the superposition of electric field components in RunMS to use complex Ex, Ey and Ez values.
- Resolved a crash that could have occurred when pressing Ctrl+Shift+F11 to enable column/line mode view in the status bar.
- Resolved an issue where RCS was computed, but no valid receiving point was defined. A warning message will now be issued if no valid receiving point defined.
- Fixed a bug for the auto-calibration in ProMan using the urban IRT propagation model that could have resulted in a crash.
- Propagation rays can now be displayed in the 3D view of projects with multiple prediction heights.
- Resolved an issue where plotting multiple 1D values along a line, the legend showed the result type of the last loaded result. The same behaviour occurred when viewing the info of a plot.

WallMan

Resolved Issues

- Resolved an issue with the layout of the **Simplify Indoor Database** dialog.
- Resolved an issue with buildings being converted multiple times when converting a CityGML database to a WinProp urban database.

Application Programming Interface

Feature

- Improved the progress output in the case of HPCs when writing output to a file, where control characters are now omitted when not recognised.

WRAP 2023.0.1 Release Notes

The most notable extensions and improvements to WRAP are listed by component.

General

Features

- Added column sorting for the **Obstacles** tab and improved the column sorting for the Method 1 **Calculation and Result** tab in ObsMan.
- Added an option in ObsMan to run method 1 and method 2 calculations without impact from weather radars.
- Added the option to activate a log file for calculations running through the API.
- A new status port has been added in the WRAP API interface. The new status port can be used to check the status of WRAP Main program, which is running through the standard API port. The new status port should be specified in the API settings file named, `APIConfigFile.txt`, that is installed by the installation program under Feko installation folder "feko\shared\wrap". More information is available in Reference Binder C16 (wrap1974D).

Resolved Issues

- Resolved a crash that could have occurred when setting the map center position at or very near one of the poles.
- Corrected a bug where values for a station already deleted from **Stations** tab are still shown on the **Coupling Loss Matrix** tab in **Edit Group** dialog.
- Corrected a bug where user-defined or imported coupling loss matrix values in a site could be reset to internally computed values after editing station information through **Stations** tab in **Edit Group** dialog.
- Any tool settings file saved with version 2023.0 is corrupt and should be replaced by a new one saved with 2023.0.1 or later.
- Corrected a bug where WRAP would go into an infinite loop when showing maps containing area patches.
- Corrected a bug where it was not possible to enter the raster database resolution for raster databases created with earlier versions of WRAP.
- ESRI GRIDASCII files are now converted correctly with respect to x/yllcenter and x/yllcorner.
- Resolved a crash that occurred when printing to A3 pdf in WRAP FM.
- Resolved an issue in ObsMan where if an obstacle was located at lat-long (0, 0) and the station database contained any station at (0, 0), the SQL circle search statement could have caused a divide by zero exception in the ADO driver.
- Added threadlock to avoid removal of valid placement cells.
- Improved the implementation of Field Strength Calculation to optimize the computation time.
- Opening a project with maps using the API now closes any open projects with maps.

Release Notes: Altair Feko 2023

Altair Feko 2023 is available with new features, corrections and improvements. Altair Feko 2023 is a major release. It can be installed alongside other instances of Altair Feko.

This chapter covers the following:

- [Highlights of the 2023 Release](#) (p. 40)
- [Feko 2023 Release Notes](#) (p. 46)
- [WinProp 2023 Release Notes](#) (p. 51)
- [WRAP 2023 Release Notes](#) (p. 52)

Feko is a powerful and comprehensive 3D simulation package intended for the analysis of a wide range of electromagnetic radiation and scattering problems. Applications include antenna design, antenna placement, microstrip antennas and circuits, dielectric media, scattering analysis, electromagnetic compatibility studies including cable harness modelling and many more.

newFASANT complements Altair's high frequency electromagnetic software tool (Altair Feko) for general 3D EM field calculations, including, among others, special design tools tailored for specific applications like complex radomes including FSS, automated design of reflectarrays and ultra-conformed reflector antennas, analysis of Doppler effects, ultrasound systems including automotive or complex RCS, and antenna placement problems. Advanced solver technologies like the MoM combined with the characteristic basis functions (CBFS), PO/GO/PTD, GTD/PO and MLFMM parallelised through MPI/OpenMP, being some of them especially efficient for the analysis of electrically very large problems.

WinProp is the most complete suite of tools in the domain of wireless propagation and radio network planning. With applications ranging from satellite to terrestrial, from rural via urban to indoor radio links, WinProp's innovative wave propagation models combine accuracy with short computation times.

WRAP is a comprehensive tool for electromagnetic propagation, antenna collocation and spectrum management. WRAP combines propagation analysis, often over large areas with many transmitters and receivers, with system analysis to include complex non-linear equipment properties.

Highlights of the 2023 Release

The most notable extensions and improvements to Feko, newFASANT, WinProp and WRAP in the 2023 release.

Salient Features in Feko

- A selection of new components was added to the CADFEKO component library. Ten new antenna models (including antennas for EMC testing) and four new platform models were added.

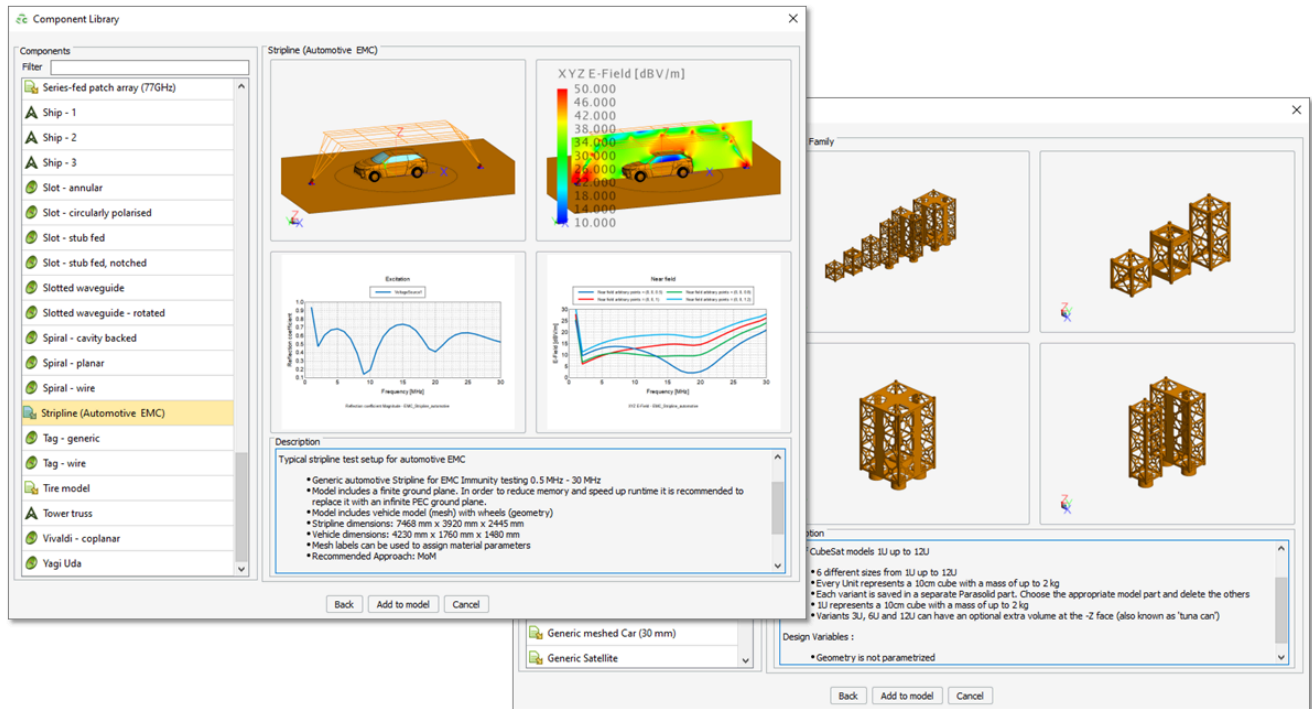

Figure 6: A selection of the new components available in the component library.

- The Altair Material Data Centre is now populated with media from CADFEKO. Import the media and use in Feko simulations.
- Reduced solution method limitations:
 - SEP regions (dielectrics) can be used in the MoM part of the solution for coupled and uncoupled scenarios with RL-GO.
 - Lossy dielectrics can be included in characteristic mode analysis calculations.
 - Loading restrictions have been relaxed to model direct/strong coupling between the inner and outer regions at the cable terminations in combined MoM/MTL simulations.
- A new tool (AMRFeko) is now available, which enables automatic adaptive mesh refinement based on error estimates for FEM and MoM/FEM solutions. The fully-automatic tool can be launched from a command prompt or any of the Feko GUIs and can also be used on HPC resources in a similar fashion to RUNFEKO.

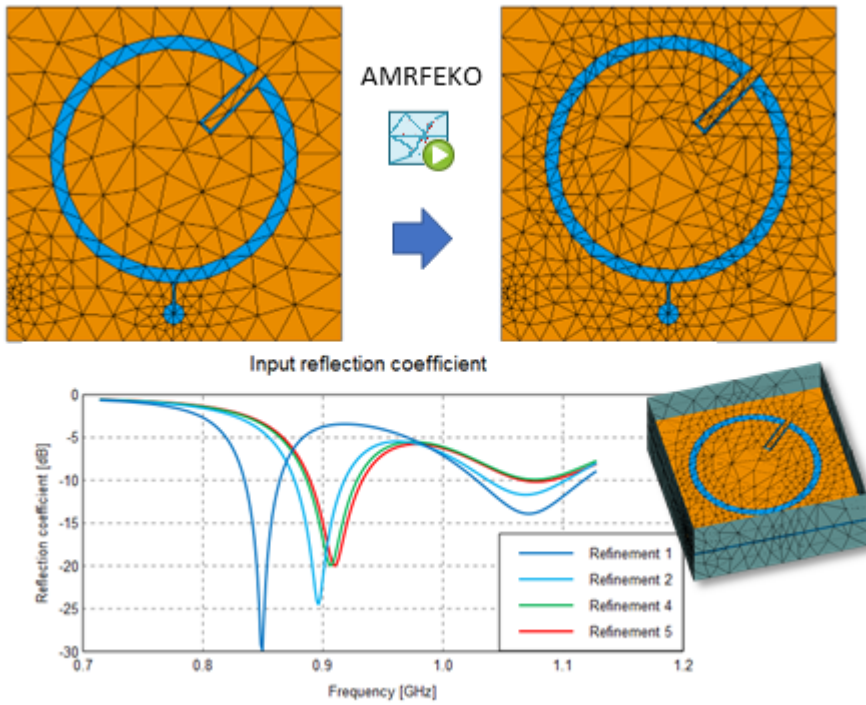

Figure 7: An example of a model refined using AMRFEKO; Left: unrefined, Right: final refinement.

- A new domain connectivity approach allows meshes of specific parts to be treated as if “connected” during MoM and MoM/MLFMM solutions in places where the borders of the meshes are close together, even if the mesh vertices on those borders are not coincident. Domain connectivity can now be configured in CADFEKO (new in 2023) or EDITFEKO (since 2022.3) and visualized in POSTFEKO (new in 2023).

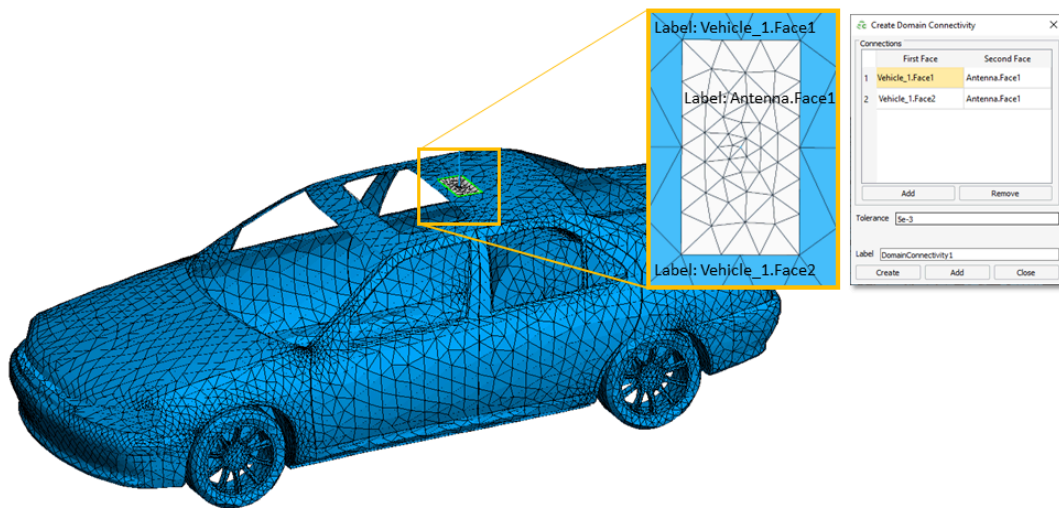

Figure 8: A static imported car mesh and a parameterised antenna geometry viewed in POSTFEKO where the **Domain Connectivity** display tool highlights edges in green that are connected using domain connectivity.

- CBFM is a modification of the conventional method of moments (MoM) that reduces the number of unknowns using macro basis functions. This approach could be used with MoM from Feko 2022.3 but is now available for use with MoM/MLFMM – helping achieve a substantial performance improvement over MLFMM in some applications such as monostatic RCS calculations of large objects with similar solution accuracy compared to the default solution.

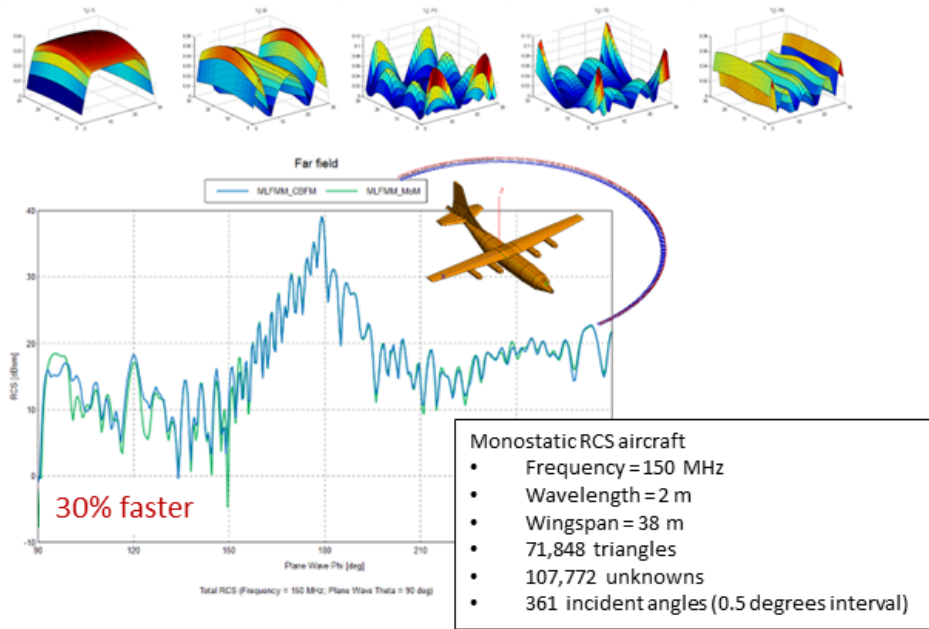

Figure 9: An example of a monostatic RCS calculation of an aircraft solved with MLFMM and MoM/MLFMM.

Salient Features in WinProp

- Modified the beam assignment algorithm to use the rays of the receiving pixel leading to more accurate results.

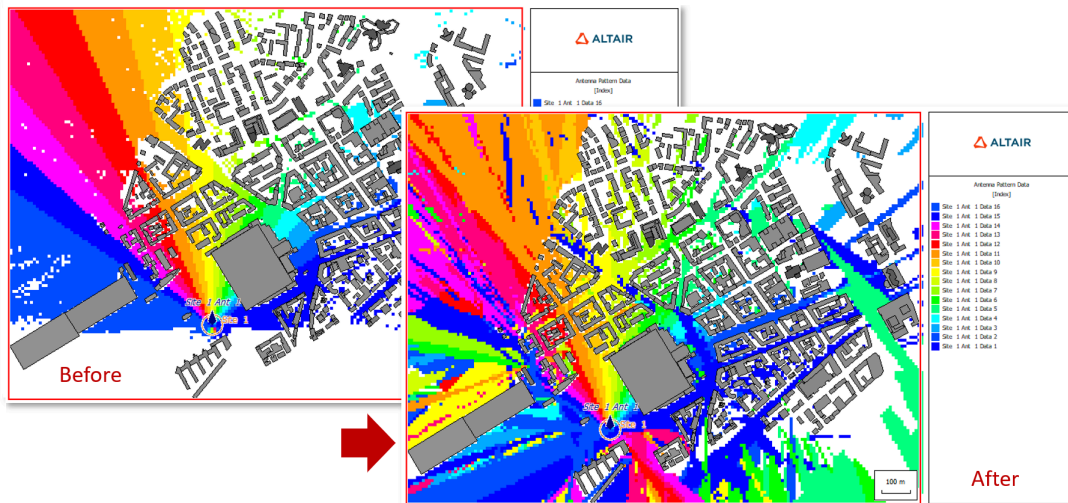

Figure 10: A before (left) and after (right) example of improved beam assignment algorithm.

- Arbitrary prediction planes can now be viewed in the 2D view by selecting the plane from the prediction plane drop-down list. In the past, arbitrary prediction planes could only be viewed in the 3D view. This option is useful when viewing vertical planes of the Parabolic Equation (PE) model.

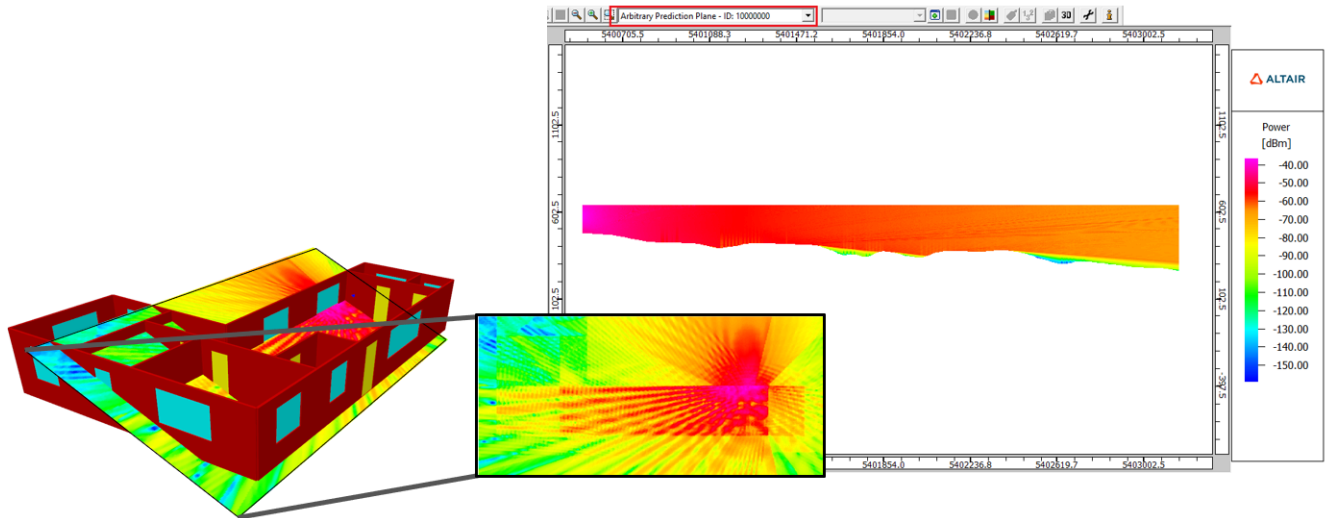

Figure 11: Examples of arbitrary prediction planes that are now available in the prediction plane drop-down list. Left: Arbitrary plane in an indoor scenario in the 3D view and new 2D view; Right: A vertical prediction plane used in the PE model.

- The pixel center and pixel grid can be enabled on the **Default Settings** dialog.

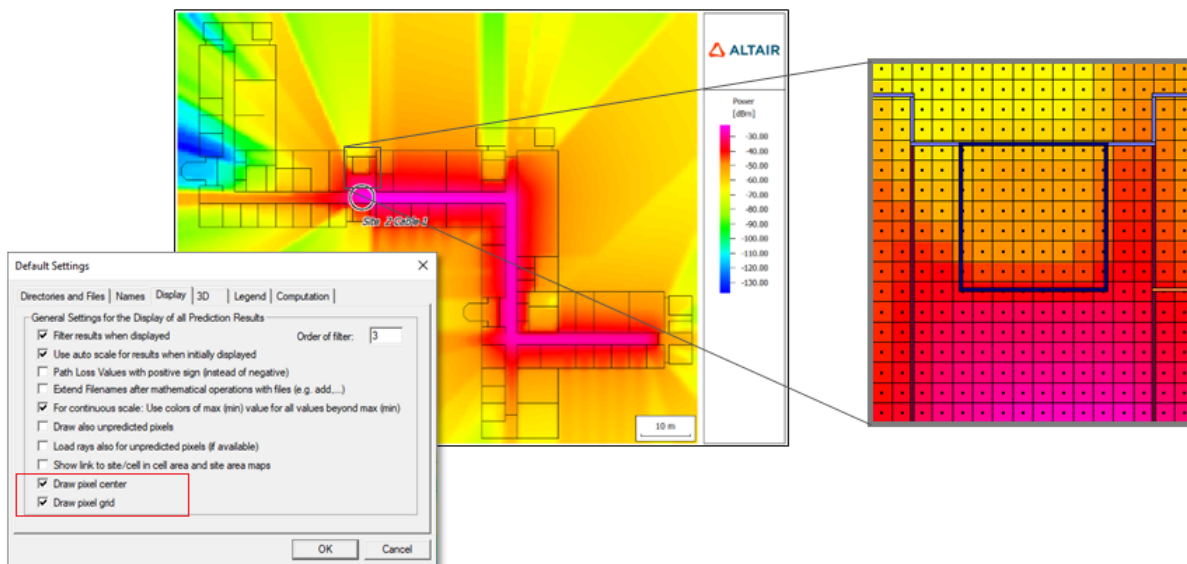

Figure 12: An example of an indoor database where the pixel center and pixel grid were enabled on the **Default Settings** dialog. For a large database, zoom-in to view the pixel center and pixel grid.

- Added the new wireless standard definition files (.wst^[1]) for WiFi 7 (802.11be) and updated WiFi 6 (802.11ax). ProMan was extended to support the new 4096-QAM transmission modes for WiFi 7 (802.11be).

Salient Features in WRAP

- Added a new and improved format for height and landcover maps to WRAP and MapDataManager that have non-integer resolutions and are backwards compatible with the old format. To support coordinates and resolutions with non-integer arc second values, modifications were made to MapData Manager and height/clutter data reader functions. For this new format, WRAP supports horizontal resolution in micrometers, and vertical resolution in mm. This will assist detailed prediction and planning, involving maps with finer vertical and horizontal details of height and clutter (land use) data.
- The ITU-R P. 1409 propagation model was added to WRAP, which provides propagation predictions for radio communication systems or networks using high-altitude platform stations (HAPS) or other elevated stations in the stratosphere. The model is valid from 1 GHz and above.

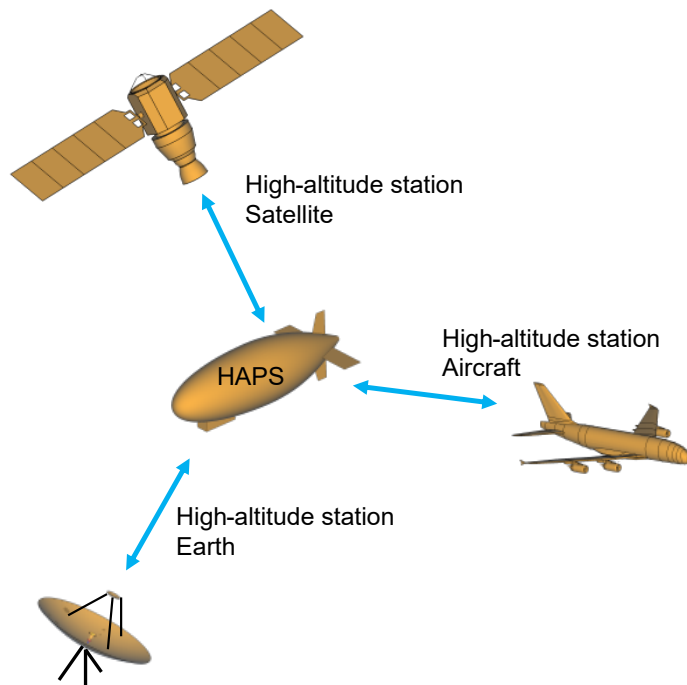

Figure 13: Propagation paths for high-altitude station.

- Added support to calculate the LTE sub-carrier interference between neighbouring co-channel LTE base stations. The user has the option to select the strongest co-channel interference only, or all interference, in addition to defining the cell load. The option is used when LTE transmitters exist in coverage calculations that make use of interference, for example, RSSI, RSRQ, Data rate, Throughput, SINR.

1. Available in the `\help\winprop\examples\ExampleGuide_models\Example-A07-Air_Interfaces_aka_Wireless_Standards.zip` folder.

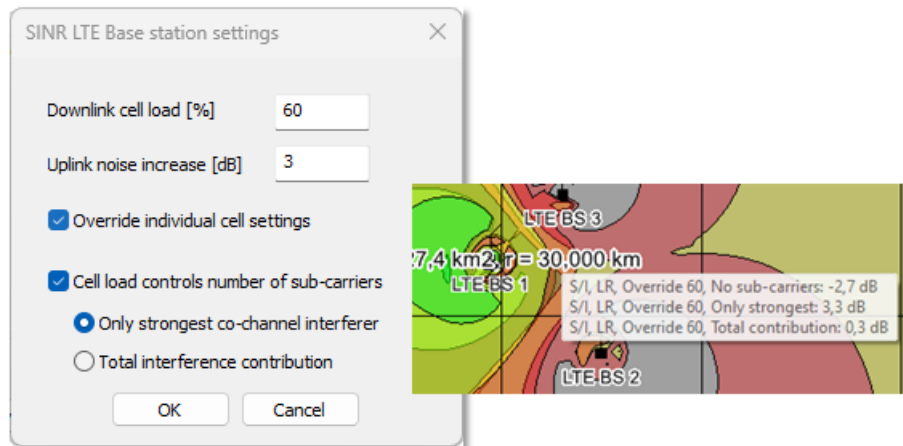

Figure 14: The **SINR LTE Base station settings** dialog where you can select the strongest co-channel interference only, or all interference, in addition to defining the cell load.

Feko 2023 Release Notes

The most notable extensions and improvements to Feko are listed by component.

CADFEKO

Features

- Added the **Find Cable** tool.
- Antenna arrays are now supported when importing a `.cfx` file.
- Extended the waveguide mesh port to support curvilinear faces.
- Added auto-delete of the waveguide mesh port when the referenced mesh topology is deleted with vertex definition (for both normal and curvilinear faces).
- Implemented unlinking of waveguide mesh ports (for both normal and curvilinear faces).
- The **Adaptive Refinement** mesh refinement rule option was renamed to **Error Estimate Refinement**. The old API (`MeshRefinementRules:AddAdaptiveRefinement`) is still supported.
- Model mesh boundary edges and boundary faces are exposed on the details tree. This change allows visualisation of these model mesh boundary faces and boundary edges in the 3D view.
- Added support to group mesh refinement rules.
- Added support for adding edge mesh refinements. This allows mesh refinement of geometry or model mesh edges.
- Improved application startup behaviour by showing the splash screen earlier during startup. This provides more immediate feedback to the user that the application had been launched.
- Enable the combination of CBFM and MLFMM.
- Added support to configure domain connectivity.
- Added missing Matrix Lua bindings.
- Added the ability to export the mesh outline to a `.dxf` file as two-dimensional data by projecting it onto the XY plane.
- Added a histogram to the **Mesh Info** dialog for a visual representation of the distribution of simulation mesh edge lengths.
- Extended FEM line ports to cause mesh refinement around the port.
- New instances of CADFEKO will have default tree branches expanded by default. An application session will remember the tree expansion setting as new models are created or loaded. Details trees will remember collapsed states of the collection when swapping between entities.
- Added support to hide individual cable paths by clicking on the related icon in the model tree.
- Improved the **Mesh Info** dialog to indicate whether a specific part or all parts are considered in the calculation of the displayed mesh information.
- Added the same limits of student licences in legacy CADFEKO to new CADFEKO.
- Added support to hide individual named points by clicking on the icon for that named point in the model tree.

- Various models have been added to the component library. When using these components, design or configuration options that are available with other component library models are not shown, but rather a preconfigured model is imported into the open project. The user may then adjust variables and settings as needed.
- A model of a biconical/log hybrid (bilog) antenna for EMC immunity testing was added to the component library.
- A model of a horn antenna for EMC immunity testing was added to the component library.
- A model of a log periodic antenna for EMC immunity testing was added to the component library.
- A model of a stripline antenna for EMC immunity testing was added to the component library.
- A model of a reflectarray was added to the component library.
- A model of a generic satellite was added to the component library.
- A model of an open boundary quad-ridged horn antenna was added to the component library.
- A model of a two-by-two corporate feed patch antenna array at 5.7 GHz was added to the component library.
- A model of a square-shaped miniature satellite (CubeSat) was added to the component library.
- A model of a base station sector antenna was added to the component library.
- A model of a series-fed patch array for 77 GHz advanced driver assistance systems (ADAS) radar was added to the component library.
- Models of a generic car and tyres were added to the component library.

Resolved Issues

- Resolved an issue where face media properties were not considered for FDTD meshing.
- Resolved an assertion that failed with the message `Assertion failed: Geometry could not be transformed correctly for combining` when creating a union of geometry parts. This assert prevented the import of certain legacy CADFEKO models.
- Resolved an assertion failure that could be triggered when saving a model with defined coatings.
- Resolved a crash when opening repair and sew faces operator properties.
- Resolved an issue where the mesh size setting was scaled with mesh parts resulting in meshes that were not the correct size. The correct mesh size is now applied when re-meshing scaled mesh parts.
- Reversing normals now works correctly on all mesh face types.
- Component launch options, which could have been modified in another Feko component, for example, in POSTFEKO, are loaded when opening the component launch options tool. The options are also stored when applying changes, making it available to other Feko components while the current instance of CADFEKO is still running.
- Improved geometric region symmetry calculations by introducing a tolerance.
- Fixed a symmetric meshing problem that resulted in a verification error containing `SimulationMeshRegionEntity.cpp (614): Assertion failed: It should have 1 region.`
- Resolved an issue where reversing the model mesh element normals had no effect in the 3D view.
- Resolved an issue when exporting mesh to I-DEAS mesh (.unv) file format that resulted in reversed element normals.
- Added support to allow vertical resizing of dialogs containing tables.

- Show a warning instead of an error when face normals point in the wrong direction for the faces to be considered symmetric around a plane of symmetry.
- Symmetrical geometric entities which have a scale transform applied to them will now be correctly assessed according to the symmetry setting specified.
- Improved erratic tree behaviour. The scroll bar position no longer jumps to the previously selected item.
- Improved legacy script error feedback in the script editor so that the line at which the error occurred is reported.
- Cable dialogs now all have correct Escape and Enter key behaviour to close the dialog or accept changes without first having to change focus away from the image to another field by pressing Tab or through clicking.
- Resolved an issue where excluding a group did not exclude the entities inside of the group.
- Improved the **Save As** dialog to use the current project name (instead of the name of a previously imported file) as the suggested file name.
- Validation hierarchy notifications no longer appear as message dialogs but are shown as verification messages in the model status panel.
- Resolved an issue where the **Show Only** tool was not working as intended.
- Improved selection behaviour using the **Rectangle Select** tool.
- Point entry widgets refresh their styling when focusing into the widget.
- Fixed missing API documentation on some objects for **LocalWorkplane**.

CADFEKO [LEGACY]

Features

- When importing Cartesian boundary near field data from files, the option to ignore a face of the near field boundary is now available in both CADFEKO and legacy CADFEKO. This option should be used to achieve accurate simulation results for Cartesian boundary near field data that was computed with one face of the Cartesian boundary coincident with a conductive plane.

EDITFEKO

Features

- Enable the selection of CBFM with MLFMM at the FM card.

POSTFEKO

Features

- Added the functionality to POSTFEKO to plot complex eigenvalues.
- Added rendering support for domain connectivity.

Resolved Issues

- Resolved an assertion failure in POSTFEKO that occurred when importing a large `.fek` file.
- Implemented a correction to prevent a crash during `.fek` file updating.
- Added support to display error estimates on curved triangles (order 0.5 only) and segments.

Solver

Features

- Extended the combined MoM/MTL method to relax the loading restrictions at terminations, allowing for direct/strong coupling between the inner MTL and outer MoM regions.
- Added support for CFIE in the characteristic basis function method (CBFM).
- The characteristic basis function method (CBFM) can now be used with MoM in the Feko Solver. This implementation will be extended to support MoM/MLFMM in future releases to improve impact for a wider range of practical problems for applications such as scattering analysis.
- Added a utility for de-embedding S-parameters.
- Add support for MoM-SEP (dielectric materials) hybridized with RL-GO for both coupled and uncoupled cases.
- The calculation of FEM error indicators at metallic surfaces (infinitely thin sheets) within a FEM region has been improved. The error indicator levels are now comparable to the indicator levels in other regions of the model, impacting positively on all workflows relying on these error indicator values. The error indicator calculation phase has also been parallelized.

Shared Interface Changes

Features

- Increased the `.fek` file version to 191 to accommodate new features.
- Automatic adaptive mesh refinement can be achieved by launching AMRFEKO from the Run/Launch ribbon group. AMRFEKO options are available on the dialog launcher on the Run/Launch ribbon group. The option to launch AMRFEKO is available from CADFEKO, EDITFEKO and POSTFEKO.

Support Components

Features

- Removed the CoMan and OptMan examples from the installation and documentation. Users are encouraged to use HyperStudy for optimisation studies.
- Added a table of supported media types for each solution method to the Feko User Guide.
- Extended the Feko User Guide to include a list of solution methods supported with a multilayer substrate.

- After running a set of simulations prepared using the **Create Frequency Ranges** macro in CADFEKO, the **Combine Results** macro will automatically be launched in POSTFEKO to process and display the combined results.
- Converted the **Create Impedance Sheet for Layered Metals** application macro from the CADFEKO [LEGACY] API to the new CADFEKO API.

WinProp 2023 Release Notes

The most notable extensions and improvements to WinProp are listed by component.

General

Features

- Added new wireless standard definition files for WiFi 7 (802.11be) and updated ones for WiFi 6 (802.11ax).
- OptMan is deprecated and removed from the installation.
- CoMan is deprecated and removed from the installation.
- Upgraded the CityGML converter and corrected an issue where buildings were added multiple times.

ProMan

Features

- Added support to view arbitrary prediction planes in the 2D view. The display of the pixel center and pixel grid can be enabled on the **Default Settings** dialog (**Display** tab).
- Modified the beam assignment algorithm to use the rays of the receiving pixel leading to more accurate results.

WallMan

Features

- Added an error message that urban preprocessing with negative coordinates is not possible.

Resolved Issues

- Resolved an issue when saving an indoor database (.idb) as an outdoor database (.odb).

WRAP 2023 Release Notes

The most notable extensions and improvements to WRAP are listed by component.

General

Features

- Add three options (best-case, worst-case, and mean) for methods to combine multiple coverage results in the composite function.
- Added support to define a threshold in the coverage comparison tool.
- The demo database shipped with WRAP now contains LTE Base Station Template, Mobile Station, Transmitter and Receiver (for LTE Band1) for LTE Coverage Calculations.
- The size of the icons in WRAP Toolbar has been modified to adapt to the display resolution.
- Added support for calculating LTE sub-carrier interference between neighbouring co-channel LTE base stations in the Coverage tool.
- Implemented the ITU-R P. 1409 propagation model, which provides propagation predictions for systems using high-altitude platform stations or other elevated stations in the stratosphere.
- Added support for the ITU-R P.617 model in the API with the Link Performance Tool.

Resolved Issues

- Fixed error with ObsMan Method 2 considering out of range radars, when search sector was not specified.
- Corrected some of the warnings about valid ranges in the Radio Link Performance tool.

WRAP MapDataManager

Features

- Added support for map data with non-integer and sub-integer resolutions to support high resolution maps with resolutions below 1 arcsec or below 1 m.

Release Notes: Altair Feko 2022.3.2

Altair Feko 2022.3.2 is available with new features, corrections and improvements. This version (2022.3.2) is a patch release that should be applied to an existing 2022 or 2022.3 installation.

This chapter covers the following:

- [Feko 2022.3.2 Release Notes](#) (p. 54)
- [WinProp 2022.3.2 Release Notes](#) (p. 57)
- [WRAP 2022.3.2 Release Notes](#) (p. 58)

Feko is a powerful and comprehensive 3D simulation package intended for the analysis of a wide range of electromagnetic radiation and scattering problems. Applications include antenna design, antenna placement, microstrip antennas and circuits, dielectric media, scattering analysis, electromagnetic compatibility studies including cable harness modelling and many more.

newFASANT complements Altair's high frequency electromagnetic software tool (Altair Feko) for general 3D EM field calculations, including, among others, special design tools tailored for specific applications like complex radomes including FSS, automated design of reflectarrays and ultra-conformed reflector antennas, analysis of Doppler effects, ultrasound systems including automotive or complex RCS, and antenna placement problems. Advanced solver technologies like the MoM combined with the characteristic basis functions (CBFS), PO/GO/PTD, GTD/PO and MLFMM parallelised through MPI/OpenMP, being some of them especially efficient for the analysis of electrically very large problems.

WinProp is the most complete suite of tools in the domain of wireless propagation and radio network planning. With applications ranging from satellite to terrestrial, from rural via urban to indoor radio links, WinProp's innovative wave propagation models combine accuracy with short computation times.

WRAP is a comprehensive tool for electromagnetic propagation, antenna collocation and spectrum management. WRAP combines propagation analysis, often over large areas with many transmitters and receivers, with system analysis to include complex non-linear equipment properties.

Feko 2022.3.2 Release Notes

The most notable extensions and improvements to Feko are listed by component.

CADFEKO

Resolved Issues

- Improved the performance of moving components on the cable schematic view for large models.
- Resolved an error when loading a legacy CADFEKO model if the region medium of a child geometry was set to **Plane/ground (finite)** (enclosing an infinite multilayer substrate inside a region) and **Plane/ground** was set to **No ground**. In CADFEKO, a yellow icon will indicate if the model is incorrect, and a suggested course of action will be given in the tooltip when hovering over the icon.
- Fixed a non-deterministic issue which could have resulted in a mesh shifting when loading a saved model. For models that have been saved in the broken state, it is required to remesh the model.
- Fixed a bug where saving the model would sometimes stop working after a number of save actions in the CADFEKO GUI or using a Lua script. The bug was related to the undo stack depth setting, and saving would not work correctly after performing more steps than the undo stack depth.
- Legacy CADFEKO allowed the user to specify an invalid (**Cable reference direction** on the **Create Cable Path** dialog (**Advanced** tab). The latest CADFEKO cannot convert the file but will inform the user about the errors. These errors can be corrected in legacy CADFEKO.
- Fixed an error which resulted in the **Spiral - planar**, **Spiral - cavity backed** and **Vivaldi - coplanar** antennas in the component library not created successfully.
- Resolved an issue where the mesh model port and its associated named points were not written to the `.pre` file.
- Corrected a problem where faces were incorrectly written to the `.cfm` file if the face had a coating set, even when the coating setting was ignored (disabled).
- Improved the selection of model mesh entities in the 3D view.
- The edge port orientations written to the `.pre` file have been corrected so that they are consistent for sources, non-radiating networks and transmission lines.
- Allow legacy models which result in an invalid model hierarchy to be still loaded into CADFEKO. Added a warning message indicating the failed validation to allow a user to correct the model.
- Improved the endpoint selection of a wire when there are entities behind the wire and the snap settings are set to snap to the mesh.
- Improved the performance of saving `.cfx` files for models with a large number of mesh elements.
- When loading a legacy CADFEKO `.cfx` file and a part fails to mesh, an error message will be displayed in the model status panel to indicate the face that prevented the part from meshing.
- Resolved an assertion failure with the message "UpdatingStateException" that occurred when a legacy `.cfx` file containing transforms applied to unioned geometry failed to convert to the new CADFEKO format.
- Resolved a crash that could have occurred during the conversion of a legacy `.cfx` model if a delete modifier tried to delete a face twice.

- Resolved an issue for the spin operator when the origin is non-zero.
- Corrected the `.pre` file writing for non-conducting elements.
- When calling `RunPREFEKO`, `RunFEKO` or `RunOPTFEKO` methods from the `Launcher` API, the output field will no longer contain the "linefeed", "notice", "warning" or "error" tags which are inserted when calling these Feko components with the `run-from-gui` command line argument.
- Corrected the model mesh to be transparent when the simulation mesh is displayed with overlay.
- Corrected FEM line mesh ports that reference vertices to take transformations on the mesh into account.
- Corrected the spin operation to show an arrow for the rotation angle preview.

POSTFEKO

Resolved Issues

- Resolved assertion failures that could have occurred when using the POSTFEKO **Calculate Mixed Mode S-Parameters** application macro.
- When importing data from a DRE file which contains only realized gain information and the power information required to correctly convert to accurate gain and field values is unavailable, a lossless system is now assumed and field and gain values calculated. In most cases these values will not represent the real gain and field values as there will be losses that should be accounted for.
- Resolved an error when importing DRE data on Linux systems.

Solver

Resolved Issues

- Improved the error checking mechanism when a triangular patch and a tetrahedral element overlap.
- Enforced FEM error checks for anisotropic media at a FEM outer boundary. An error message is issued if an anisotropic FEM region is not bound by FEM tetrahedra.

Support Components

Features

- Resolved an error when importing a `.rei` file with only signal layers in the stack up for the **Pre-Process PolEx Rei File** application macro.
- Added a new file format when importing custom data from a `.csv` file for a base antenna element with multiple ports for the **Generate antenna array** application macro. This is useful for differential antenna excitations and other configurations with more than one port.

Resolved Issues

- Extended the **Calculate embedded element patterns** option in the **Generate antenna array** application macro to include all port types.

WinProp 2022.3.2 Release Notes

The most notable extensions and improvements to WinProp are listed by component.

General

Resolved Issues

- Resolved an issue with TuMan tunnel geometry export to `.idb` file, which resulted in an error and incorrect exported geometry.
- A warning will now be issued, "Falling terrain is too steep, PE might be invalid", in the case of too steep decreasing terrain in conjunction with the Parabolic Equation (PE) model.

ProMan

Resolved Issues

- The **Use exact coordinates instead of vertical plane approximation** option is now also considered for the Parabolic Equation wave propagation model.
- Resolved a crash that occurred after starting an auto-calibration of a Dominant Path Model.
- Resolved an issue where the ground reflection was not computed over the total distance between the transmitter and the receiver when using the 3D Intelligent Ray Tracing (IRT) model.

WallMan

Resolved Issues

- Improved the robustness of OpenDRIVE database conversion by effectively handling numerical precision issues.

Application Programming Interface

Features

- Extended the FMCW API example to generate Range-Angle Heatmaps.

WRAP 2022.3.2 Release Notes

The most notable extensions and improvements to WRAP are listed by component.

General

Resolved Issues

- Error in ObsMan method 1 calculations has been corrected. The error could cause obstacles to be set to **OK to build** when using the worst case method, if the case had not been previously saved, closed and loaded again in ObsMan. Now it works correctly also for a newly created unsaved case.

Release Notes: Altair Feko 2022.3.1

Altair Feko 2022.3.1 is available with new features, corrections and improvements. This version (2022.3.1) is a patch release that should be applied to an existing 2022 or 2022.3 installation.

This chapter covers the following:

- [Feko 2022.3.1 Release Notes](#) (p. 60)
- [WinProp 2022.3.1 Release Notes](#) (p. 64)
- [WRAP 2022.3.1 Release Notes](#) (p. 65)

Feko is a powerful and comprehensive 3D simulation package intended for the analysis of a wide range of electromagnetic radiation and scattering problems. Applications include antenna design, antenna placement, microstrip antennas and circuits, dielectric media, scattering analysis, electromagnetic compatibility studies including cable harness modelling and many more.

newFASANT complements Altair's high frequency electromagnetic software tool (Altair Feko) for general 3D EM field calculations, including, among others, special design tools tailored for specific applications like complex radomes including FSS, automated design of reflectarrays and ultra-conformed reflector antennas, analysis of Doppler effects, ultrasound systems including automotive or complex RCS, and antenna placement problems. Advanced solver technologies like the MoM combined with the characteristic basis functions (CBFS), PO/GO/PTD, GTD/PO and MLFMM parallelised through MPI/OpenMP, being some of them especially efficient for the analysis of electrically very large problems.

WinProp is the most complete suite of tools in the domain of wireless propagation and radio network planning. With applications ranging from satellite to terrestrial, from rural via urban to indoor radio links, WinProp's innovative wave propagation models combine accuracy with short computation times.

WRAP is a comprehensive tool for electromagnetic propagation, antenna collocation and spectrum management. WRAP combines propagation analysis, often over large areas with many transmitters and receivers, with system analysis to include complex non-linear equipment properties.

Feko 2022.3.1 Release Notes

The most notable extensions and improvements to Feko are listed by component.

CADFEKO

Features

- Corrected CEM validation to give a warning instead of an error for geometrically thin faces.
- Added a fallback for legacy CADFEKO models that fail to convert to the new CADFEKO format when opening the model. If geometry fails to convert, the respective geometry is converted to a primitive. If geometry consisting of boolean operators (for example, union, subtract) fails to convert, it is converted to a primitive inside a group to show the creation hierarchy.
- When importing Cartesian boundary near field data from files, the option to ignore a face of the near field boundary is now available. This option should be used to achieve accurate simulation results for Cartesian boundary near field data that was computed with one face of the Cartesian boundary coincident with a conductive plane.

Resolved Issues

- Corrected the `.pre` file writing of the DI card for defining an anisotropic dielectric (Polder tensor).
- For a model with many near field requests, an assert is no longer triggered when clicking in the model tree while the near fields are being rendered (after switching to the **Configuration** tab).
- Cable instance and cable tube cross-section previews have been fixed to no longer show an empty preview intermittently.
- Resolved a regression that caused signals and signal labels to be oriented incorrectly on the **Cable Bundle** and **Cable Instance** dialogs.
- Improved the selection, right-click, double-click and moving behaviour of overlapping cable elements on the cable schematic view.
- Resolved an issue where viewing the properties of a model mesh could have caused CADFEKO to become unresponsive.
- Fixed a bug that could have caused overlapping segments when a model has multiple wire mesh ports.
- Resolved issues related to rendering windscreen layers, such as the offset for the reference surface that was not considered and layers that were added in the wrong direction.
- The conversion of a legacy CADFEKO model failed if the model contained an invalid outer radius for a cable bundle. A model status error will now be issued to indicate an incorrect outer radius.
- Resolved an issue where DP card values were incorrectly rounded.
- Fixed the visibility and rendering of edge ports (mesh and geometry) when connected to a ground plane.
- Resolved an issue where loads, general networks and transmission lines were not referencing the root level face of edge ports in the `.pre` file, resulting in a solver error.
- Resolved an issue that may have caused failure during the creation of an analytical curve.

- Refined the validation for cable ribbon core spacing to use a special tolerance.
- Added support to allow editing invalid entities in the tree. Previously the **Properties** option on the context menu was disabled for invalid items.
- Resolved a crash that occurred when closing the **Application Macro Collection** dialog while a script was still running.
- Fixed the conversion of legacy CADFEKO `.cfx` files that contained a loft operator.
- Performance has been improved when opening legacy CADFEKO models in CADFEKO that contain many parts and deeply nested geometry trees.
- Corrected validation to issue a warning instead of an error when meshing fails to allow the model to be corrected.
- For a model that contains a layered dielectric, modifying face properties with the coating disabled assumes the value of the layered dielectric. Deleting the layered dielectric and saving the model will no longer trigger an assert.
- Resolved an error that occurred when loading legacy `.cfx` files on AMD CPUs.
- Resolved an issue that caused an assertion to fail when exporting a model mesh with symmetry and a wire mesh port to a `.cfm` file.
- Increased the number of significant digits for snap points in the status bar.
- Resolved an issue where defining a port on a wire with multiple segments could have caused a solver error.
- Resolved an error where opening a legacy CADFEKO model failed to convert to the new CADFEKO format if there were duplicate element names on the network schematic view.
- Resolved an issue where opening a legacy CADFEKO `.cfx` file where no `.efe` or `.hfe` files were specified failed to convert to the new CADFEKO format. If no file names are specified, defaults are provided, and a warning is issued.
- Improved calculation of the distance between a cable harness and the closest conducting surface when performing model validation.
- Resolved a problem where legacy `.cfx` files failed to convert to the new CADFEKO format for adaptive mesh refinement models. Improved the bounding box (model extents) for mesh refinement and darkened the mesh refinement display.
- Mesh vertices close to a symmetry plane will snap to the symmetry plane to avoid tolerance errors during simulation.
- Fixed an assertion that could fail when geometry containing wires was converted to a primitive.
- Some crashes will no longer be triggered when importing selected `.cfx` files into CADFEKO.
- Improved the legacy CADFEKO `.cfx` file conversion to the new CADFEKO format to support S-parameters that reference ports on networks.
- Improved rectangle selection tool so that wires and edges can also be selected.
- Implemented missing rendering functionality for wire connectivity.
- Improved the rendering of the line preview to prevent flickering.
- Resolved an issue where cable signals were incorrectly positioned on the **Cable Instance** dialog.
- Fixed the conversion of legacy CADFEKO files that contained analytical curves. The same analytical curves created in legacy CADFEKO, can now also be created in the CADFEKO.

- RUNFEKO dialog output is no longer duplicated when launching multiple runs from the same CADFEKO instance.
- Added an error dialog that states the reason for failure when attempting to launch CADFEKO on a system where the required OpenGL version is not supported or available. Previously this may have failed silently, or the ribbon may have become unresponsive.
- Resolved an issue where validation prevented the use of an FDTD ground plane. Added support for applying an edge mesh port to an FDTD ground plane.
- Fixed the incorrect rendering of edge ports.
- Empty (default) solution configurations are not loaded when importing a `.cfx` file. If the target model contains a single empty configuration, it is removed before adding the non-empty configurations from the imported `.cfx` file.
- Resolved an issue where the contents of an assertion dialog were not added to the clipboard.
- Resolved an issue where legacy CADFEKO `.cfx` files containing cable shields did not convert successfully when the transfer impedance was defined from a file.
- Resolved a circular reference assert that occurred when converting a legacy CADFEKO model containing an edge port with a voltage source connected to an FDTD boundary PEC plane.

EDITFEKO

Features

- Extended the AP and RA card to ignore a face (or faces) of the near field boundary when importing Cartesian boundary near field data from files.

Resolved Issues

- Resolved a problem where the license units were not checked back in upon closing EDITFEKO.

Solver

Features

- Added improved error checking when an impressed current coincides with, or is defined too close to triangular mesh elements.

Resolved Issues

- Improved the accuracy of faceted UTD simulation of some models in the shadow region.
- Resolved a problem where an error may have been encountered when running with the MPICH shipped with Feko on Linux due to libfabric dependencies.
- Improved the accuracy of results of cable simulations involving twisted wire pairs.
- Resolved an error that may have resulted in extremely long processing times during the ray-tracing phase of RL-GO or faceted UTD with shared memory enabled.
- Avoid a floating point exception when computing a vector perpendicular to the cable path direction from the specified reference direction (used to orientate the cable cross section).

- Losses in metallic triangles and layered dielectric media are now reported together under the “Metal and layered dielectric” entry of the summary of losses table in the `.out` file.

Support Components

Features

- Added the capability, to remove selected faces of imported near field sources on a Cartesian boundary or CST near field data, in PREFEKO. This option is available for both receiving antennas and aperture field sources.
- The **Practical Guide to Ports and Sources** is now available in the `/help/feko/pdf` folder. The document highlights essential information regarding ports and sources in Feko. It also shows practical examples of feeding typical structures such as waveguides, coaxial cables and microstrip structures.
- Added a troubleshooting topic in the Feko User Guide on how to solve a drop-down list flashing with mouseover.

Resolved Issues

- Resolved an error that occurred when loading math libraries during an OPTFEKO run on AMD CPUs.
- Corrected the loading of the **Associate max frequency with var** variable list for the **Create Frequency Ranges** macro.
- Fixed an issue with the **Parameter Sweep** application macro. Certain models have dependent files that are not copied along with the model files in previous versions.
- Corrected ADAPTFEKO processing of modal port data blocks in case of multiple solutions per frequency.
- Fixed the layer assignment in the PCB stack up for a PCB with signal and ground traces on a layer in the **Pre-process REI File**.
- Updated the **Create Inductive Charging Coils** application macro to use the CADFEKO label convention when creating the coil with other GPM and CPM turn combinations other than the default.
- Resolved assertion failures when some application macros were cancelled.

WinProp 2022.3.1 Release Notes

The most notable extensions and improvements to WinProp are listed by component.

ProMan

Features

- Multiple transmitter sites can now be deleted at once. This was restricted to one site deletion at a time in previous releases.
- The display of selected rays can now be toggled on and off using the space bar.

Resolved Issues

- A warning is given when an Angle-Range Heat Map with incoherent ray superposition is requested to indicate that coherent ray superposition will be used instead.
- Resolved antenna duplicate name errors when defining multiple satellite transmitter sites from an Almanac file. Name collision is avoided by appending the site number to the name of the antenna.
- Improved the calculation accuracy for cases where an antenna has been given a significant downtilt in a fully polarimetric project.
- RCS objects are not considered for interactions when outside database polygons.

WallMan

Resolved Issues

- Fixed a WallMan crash when attempting to define time-variance along a trajectory.
- Coordinates of the converted indoor database are now consistent with those of the original CityGML file.

WRAP 2022.3.1 Release Notes

The most notable extensions and improvements to WRAP are listed by component.

General

Features

- Updated result of get Allotment API message to be inline with modify Allotment.

Resolved Issues

- Resolved duplication of stations in the database when a site is created through API.

Release Notes: Altair Feko 2022.3

Altair Feko 2022.3 is available with new features, corrections and improvements. It can be applied as an upgrade to an existing 2022.2 installation, or it can be installed without first installing Altair Feko 2022.2.

This chapter covers the following:

- [Highlights of the 2022.3 Release](#) (p. 67)
- [Feko 2022.3 Release Notes](#) (p. 71)
- [WinProp 2022.3 Release Notes](#) (p. 75)
- [WRAP 2022.3 Release Notes](#) (p. 77)

Feko is a powerful and comprehensive 3D simulation package intended for the analysis of a wide range of electromagnetic radiation and scattering problems. Applications include antenna design, antenna placement, microstrip antennas and circuits, dielectric media, scattering analysis, electromagnetic compatibility studies including cable harness modelling and many more.

newFASANT complements Altair's high frequency electromagnetic software tool (Altair Feko) for general 3D EM field calculations, including, among others, special design tools tailored for specific applications like complex radomes including FSS, automated design of reflectarrays and ultra-conformed reflector antennas, analysis of Doppler effects, ultrasound systems including automotive or complex RCS, and antenna placement problems. Advanced solver technologies like the MoM combined with the characteristic basis functions (CBFS), PO/GO/PTD, GTD/PO and MLFMM parallelised through MPI/OpenMP, being some of them especially efficient for the analysis of electrically very large problems.

WinProp is the most complete suite of tools in the domain of wireless propagation and radio network planning. With applications ranging from satellite to terrestrial, from rural via urban to indoor radio links, WinProp's innovative wave propagation models combine accuracy with short computation times.

WRAP is a comprehensive tool for electromagnetic propagation, antenna collocation and spectrum management. WRAP combines propagation analysis, often over large areas with many transmitters and receivers, with system analysis to include complex non-linear equipment properties.

Highlights of the 2022.3 Release

The most notable extensions and improvements to Feko, newFASANT, WinProp and WRAP in the 2022.3 release.

Salient Features in Feko

- In previous versions of Feko, mesh connectivity between parts could only be achieved when the parts had a common interface with shared vertices (a continuous mesh). For most geometric changes, the whole model needed to be re meshed to maintain connectivity between parts. When making localized geometric changes in large models or models that include imported meshes (for example, generated using Altair HyperMesh or Altair SimLab), the requirement to re mesh all connected parts to maintain connectivity can be challenging.

In Feko 2022.3 for MoM and MoM/MLFMM simulations, a new domain connectivity option was added. By specifying Domain Connectivity for specific parts, the meshes of those parts will be treated as if “connected” in places where the borders of the meshes are close together even though the mesh vertices on those borders are not coincident. This means that parts that have not changed do not need to be re meshed.

A typical use case would be an antenna placement study, where an antenna (parameterised geometry) is placed on the roof of a large pre-generated car mesh (static mesh), see [Figure 15](#).

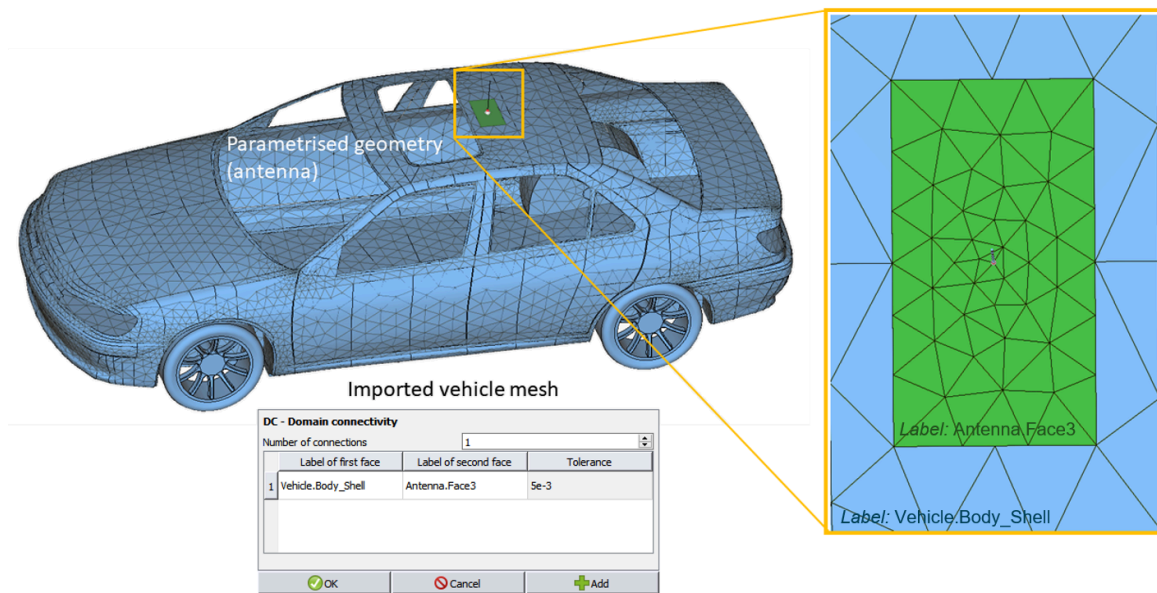

Figure 15: An installed performance study using a static imported car mesh and a parameterised antenna geometry. Though there are no shared mesh vertices between the car roof and the antenna ground plane, the roof and antenna ground plane will be treated by the MoM/MLFMM Solver as if “connected” based on the Domain Connectivity specified in a DC card.

- In addition to some performance improvements and bug-fixes, the Next-generation CADFEKO has been improved and extended to include various features that were available in CADFEKO [LEGACY]. A collection of some of these features is shown in [Figure 16](#).

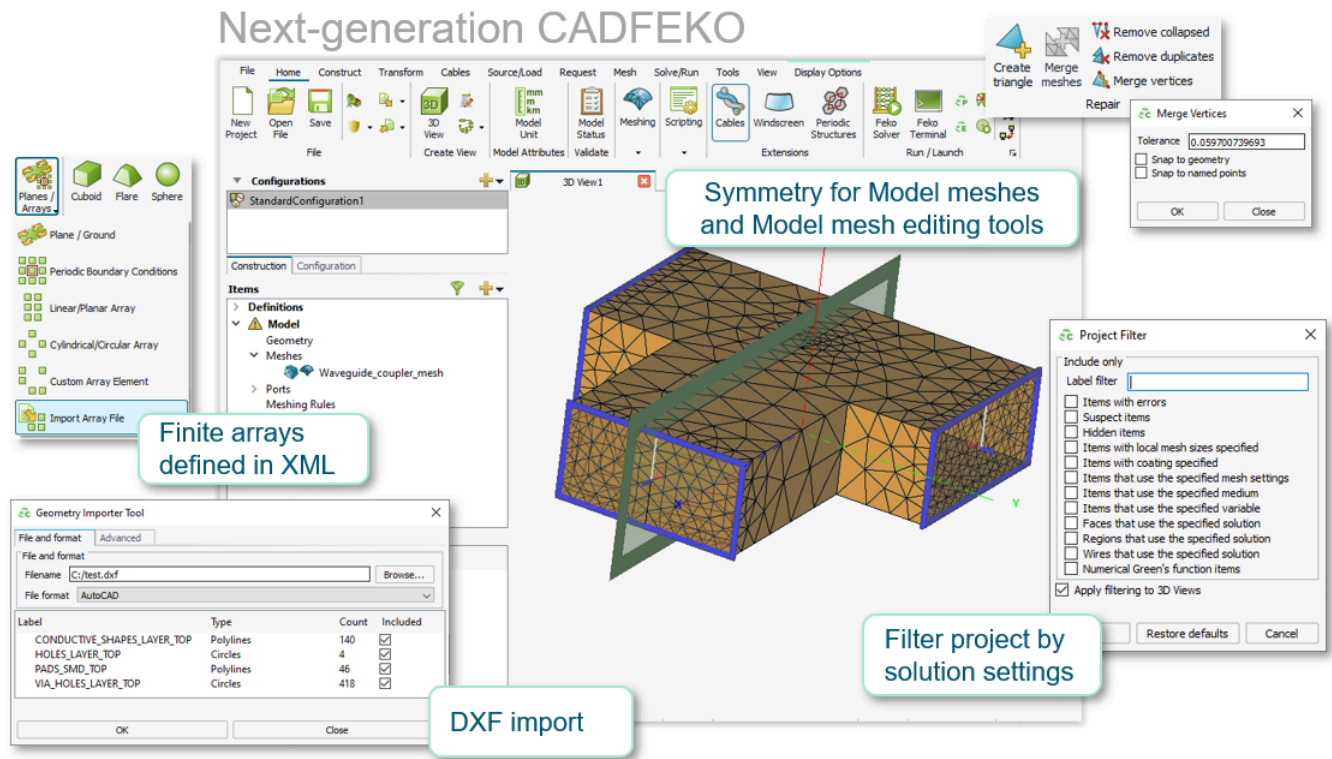

Figure 16: Some of the extensions added to the new CADFEKO interface implementation.

- Waveguide mesh ports can now be defined using mesh vertices. This option can be used when specifying a waveguide mesh port for FEM.
- The **Feko Source Data Viewer** now supports reduced `.rei` files generated by Altair PolEx, where data that will have little impact on radiated emissions calculations is excluded to reduce both `.rei` file and simulation times.
- 2D surface graphs in POSTFEKO were extended to support interactive zooming.

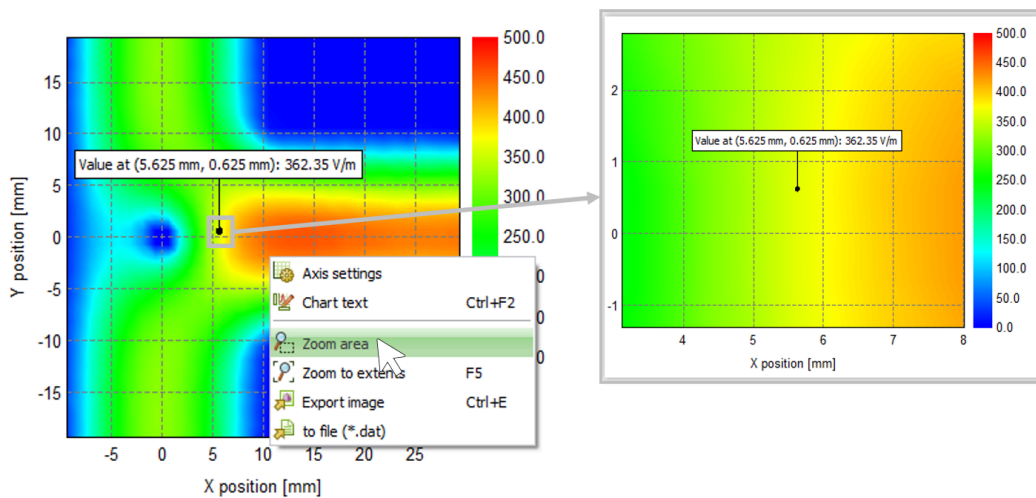

Figure 17: Surface graphs in POSTFEKO support interactive zoom.

Salient Features in WinProp

- Object dynamics can now be imported from a `.csv` file for non-preprocessed indoor databases. Once the dynamics are imported, the time-variant parameters are greyed out, and the values are set from the file.

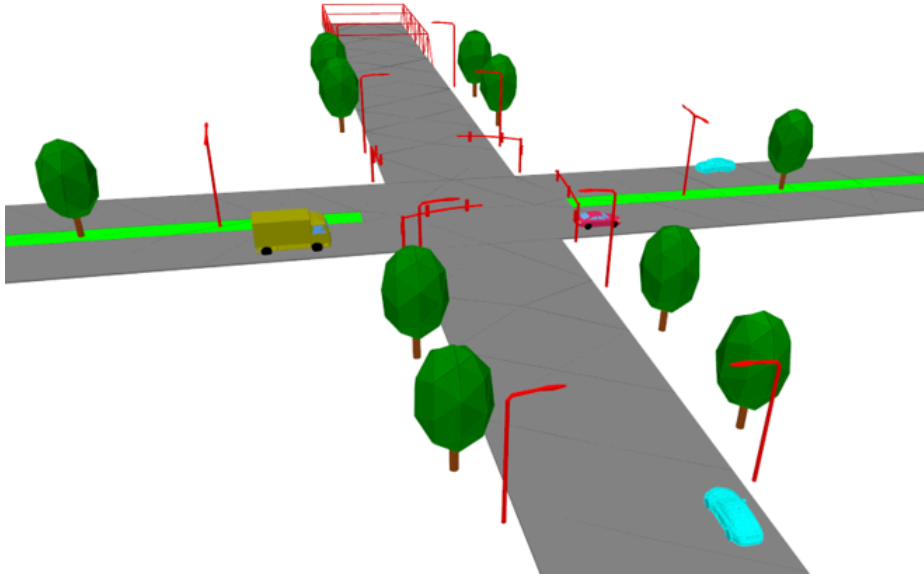

Figure 18: An example of object dynamics (moving vehicles in traffic).

- The ASAM OpenDRIVE format (provides a road network description that is used to simulate and validate ADAS features) can now be converted to WinProp indoor format.

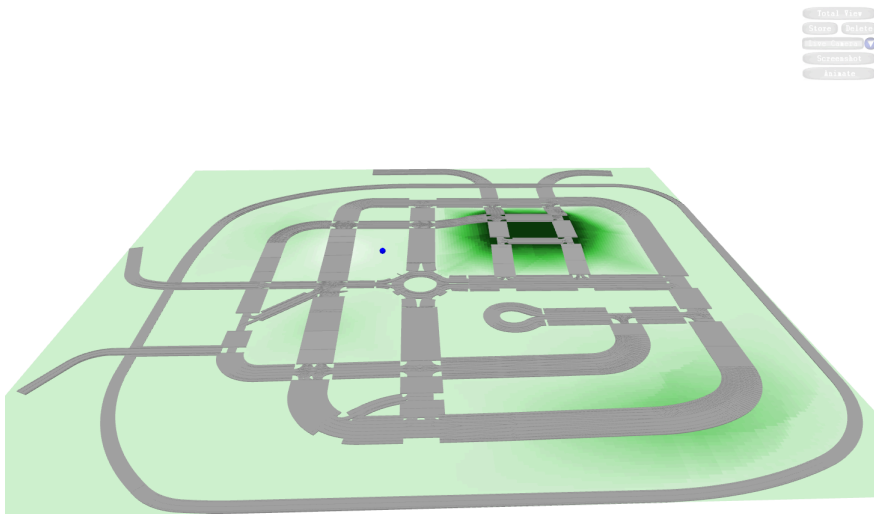

Figure 19: An example of a converted OpenDrive database.

- Trajectories can now be imported from a `.csv` file. Measured results can be included to visualise and compare measured results against WinProp results by adding a column in the `.csv` file. The measured results will not show up in the result tree, but a result file will be placed in the results folder.

- The following extensions were made to the Shooting and Bouncing Rays (SBR) method:
 - For projects that use an antenna pattern at the transmitter, the SBR method is accelerated by incorporating the antenna's gain in path loss estimation.
 - For calculations involving scattering, the accuracy is improved, and the memory consumption is reduced.
- Noise barriers along roads or highways can now be included in urban databases by drawing polylines in WallMan to represent walls.

Salient Features in WRAP

- For LTE communication systems, the following extensions were added:
 - The reporting of key performance indicators such as RSRP, RSRQ and RSSI.
 - For systems that employ multiple transmission modes, predict data rates and throughput at any receiver (mobile-station) location based on quantities like minimum required received power and minimum Signal-to-Noise-and-Interference Ratio.
 - The effect of MIMO is included.
- The map viewer was extended to include population density.

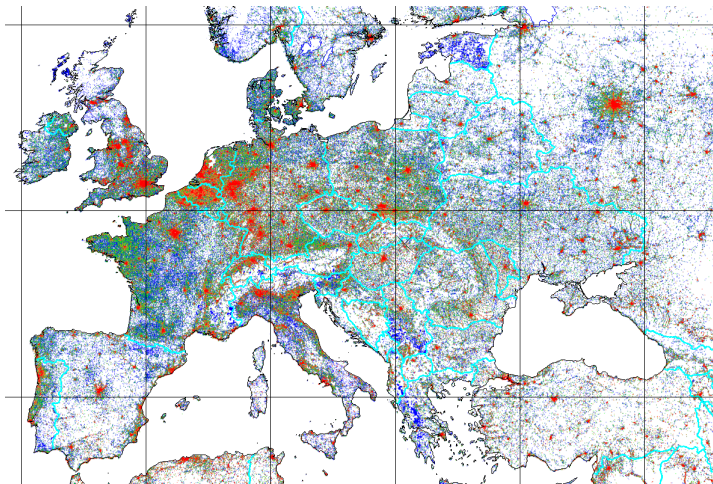

Figure 20: An example of population density included on the map viewer.

Feko 2022.3 Release Notes

The most notable extensions and improvements to Feko are listed by component.

CADFEKO

Features

- Extended waveguide mesh ports to specify the mesh port using vertices. Use the vertices when specifying a waveguide mesh port for FEM.
- Resolved issues related to the rendering of antenna arrays in the 3D view, such as the missing preview for arrays and rendering of ports and transformed elements. Improved the rendering of an active array element when a ground plane is present.
- Added support for the import of a finite array configuration from a `.xml` file.
- Added the ability to import mesh segments with different radii from `.fek` files.
- Added the ability to create mesh triangles for model meshes.
- Added the ability to remove duplicate model mesh triangles.
- Added the ability to merge model mesh vertices within a given tolerance.
- Added the ability to remove collapsed triangles from model meshes.
- Added the ability to merge triangle labels in a model mesh.
- Added support for editing the radius of individual wire segments in a model mesh.
- Extended the Feko Source Data Viewer to support reduced models with removed segment frequency data.
- The icons in the tree have been reordered. item selection and Show/Hide behavior has been improved.
- Extended geometry import to include AutoCAD `.dxf` files.
- Implemented missing print functionality for the script editor.
- Added the **Model** tab to the **Default Settings** dialog to include default model settings such as model unit, solution settings, export of files and MLFMM/ACA settings.
- The project filter in CADFEKO has been extended to allow filtering of visibility of items the geometry tree and 3D view based on solution settings.
- Extended the **Create Unit Cell** dialog to include an offset that allows shapes to be moved from the origin.
- Added an option to disable writing of the `.pre` file when saving the model.
- Added the **Request** tab to the **Default Settings** dialog to include default request settings such as far fields, near fields, error estimates, solution currents, S-parameters and transmission/reflection coefficient settings.
- Extended mesh import to include AutoCAD `.dxf` files.
- Improved the performance of duplicating certain geometry parts, most notably primitive parts. Various operations, such as the split operator, rely on duplicating geometry and could have been extremely slow.

- Added support for symmetry with model meshes and mesh ports.
- Added validation to inform the user that CBFM can not be used with ACA.
- Validation has been extended to provide better feedback when model decomposition is used in unsupported cases with FEM/VEP.
- The **Copy original geometry** capability has been added to CADFEKO.
- The bundle overlap detection for cables has been improved.
- Added the ability to modify the position of a model mesh vertex.
- Added the ability to modify individual mesh segment radii of a model mesh.
- Added the ability to delete mesh elements from a model mesh.
- Added the ability to delete mesh vertices from a model mesh.
- Adding missing functionality to the **Loft** tool.

Resolved Issues

- Cable validation now also takes voxel meshes (when FDTD is enabled) into account when checking for a valid mesh.
- When opening legacy CADFEKO models in CADFEKO, or reopening a model in CADFEKO that includes cable bundles, the bundling will be maintained. In some cases with earlier versions, bundling may have been unnecessarily recalculated resulting in an unintended change when opening the model.
- Added API documentation for the **MoveItems** method on the schematic view.
- Fixed a crash that could have occurred due to a tolerance issue when calculating the location of a cable probe.
- Improved the union operation for cases where it was failing.
- When performing Union operations on certain complex geometries, the Union action no longer continues indefinitely or causes the application to become unresponsive.
- Resolved an issue where saving a model during meshing did not save the mesh.
- Resolved an issue where model status errors were issued due to child entities being considered for validation instead of only considering root-level parts.
- Resolved an issue where DP card values were not being rounded to six significant digits.
- When converting a part that includes ports to primitive, the port assignments are now correctly maintained.
- When converting a part that contains local wire radius settings to primitive, the settings are correctly maintained in the converted part.
- Resolved an issue where the CI card was written incorrectly to the `.pre` file when a connector was shared between multiple cable paths.
- Improved the performance of opening models with large geometry hierarchies.
- Resolved an issue where the **Connectivity** tool did not show faces with unbounded edges in red for model meshes.
- Model mesh rendering now takes opacity into account.
- Resolved an issue where it was not possible to select mesh elements in the 3D view.
- Fixed the rendering of simulation mesh with waveguide mesh ports defined by vertices.

- Removed the **Rendering Options** dialog since the settings for rendering mode, transparency mode, 3D view text, and face displacement no longer apply to CADFEKO.
- Added right-click context menus to sliders on the **Advanced** tab of the **Create Mesh** dialog so that it is possible to restore the selected slider or all values to default.
- Fixed an assertion that occurred when importing a large `.stl` file.

CADFEKO [LEGACY]

Resolved Issues

- Fek format version errors no longer occur when importing fek files into legacy CADFEKO.

EDITFEKO

Features

- Added the new DC card that can be used to connect a discontinuous mesh and geometry where one is a static mesh and the second is dynamic parameterized geometry.

Resolved Issues

- Fixed a problem where the AR card did not accept the number of phi and theta points when defining a pattern in the `.pre` file. Opening the card panel when the card was populated with theta and phi points triggered an error that the card contained unknown field values.

POSTFEKO

Features

- Added **Zoom area** and **Zoom to extents** to the right-click context menu of surface graphs to allow for interactive zooming.

Resolved Issues

- Unexpected asserts no longer happen when using the POSTFEKO Mixed Mode S-Parameter application macro.

Solver

Features

- The HyperSpice library used by Feko has been upgraded.
- Support for SGI-MPT has been stopped.

- The Characteristic Basis Function Method (CBFM) can now be used in conjunction with MoM in the FekoSolver. This implementation will be extended to support MoM/MLFMM in future releases to improve impact for a wider range of practical problems for applications such as scattering analysis.
- The coordinates as well as element ID of defective triangles or connections are now written to the `.out` file.
- Updated Intel MKL to version 2022.2.
- Upgraded Intel MPI to version 2021.8 for Linux (though Intel MPI 2021.8 can also be used on Windows operating systems, Intel MPI 2021.2 is retained as default due to limitations observed in the number of shared memory allocations that can be made during a solution).

Resolved Issues

- When applying the RL-GO method to curvilinear meshes of certain curved geometries, the accuracy has been improved for cases where a higher number of interactions is considered in the ray-tracing.
- Fixed ACA memory problems for multiscale models.
- Improved solution stability of near singular SPICE circuit matrices. An example would be connecting ideal voltage sources in a delta configuration.
- Fixed a segmentation violation for the hybrid FEM/FMM when the FMM sparse matrix is large (more than $2^{31}-1$ entries).
- The problem of Feko simulations over multiple frequencies, running out of memory during the "Backward substitution for FEM coupling matrix" phase, that was observed on some hardware configurations, has been addressed by the IMPI upgrade to version 2021.8.
- ERROR 53420 is no longer issued during ACA matrix factorisation when running on some AMD machines.

Shared Interface Changes

Features

- Upgraded the 3D CAD modelling library, providing access to the latest Parasolid formats, bug fixes and performance enhancements.

Support Components

Resolved Issues

- Support for RCS simulations using RL-GO was improved in the Farm model to cluster application macro so that chunking is more practical.

WinProp 2022.3 Release Notes

The most notable extensions and improvements to WinProp are listed by component.

General

Features

- Intersections of DPM rays with vegetation and furniture (already considered in the computations) will now also be reported in the .str file.

Resolved Issues

- Fixed a bug in the Shooting and Bouncing Rays algorithm that caused too many rays to be spawned by diffraction at edges and wedges.

ProMan

Features

- Improved the accuracy and reduced the memory consumption of calculations involving scattering in the Shooting and Bouncing rays method.
- Accelerated the SBR solver, for projects that use an antenna pattern at the transmitter, by incorporating the gain of the antenna in pathloss estimation.
- Export in ProMan supports now transparent images in PNG and TIFF format where the not computed pixels are no longer white but transparent.
- Added to SRT the phenomenon of double edge diffraction by the same building, such that the ray grazes the roof or a side wall between the two edge diffractions. This is important for obtaining the power behind the building.
- FMCW radar post-processing is aligned now with the internal option of rays superposition (i.e. coherent or incoherent superposition of rays). It used to perform coherent superposition of rays in all cases. The power values can be computed now from the exported IQ data (in case of incoherent superposition of rays).
- Added support to import trajectories and points with propagation results.
- Enabled the import of object dynamics from a .csv file. An example that shows how to control object dynamics, such as moving vehicles in traffic, by modifying project files, is available on the Altair Knowledge Base. Such control is useful if the vehicle needs to react to radar observations within the same simulation.
- The computation window, where messages are written during the simulation, can now be resized for easier viewing.
- Added an option to the Deterministic Two-Ray Model to include the ground-reflected ray after the last diffraction point. With this option, constructive and destructive interference in the final segment of the ray path will be explicitly calculated. Without this option, the breakpoint effect will be used.

Resolved Issues

- Corrected the power of rays reflected in the specular direction at surfaces with high roughness that cause significant scattering. In some cases, this power was too high.
- Fixed an incorrect display of numbers of OFDM subcarriers for control, reference or data under OFDM Settings. Some numbers were displayed as zero while they clearly should not be zero; this was a display error only. Results were not affected.
- Prevented the creation of diffraction points on wedges with angles close to 180 degrees in the Urban Dominant Path Model.
- Improved transmission loss consideration in the SBR solver for cases where there are interaction points in multiple nearby objects.
- Fixed a bug in which a ray path through vegetation could have an unintended negative power loss.

WallMan

Features

- Added the capability to draw polylines in urban databases to represent walls such as noise barriers along roads.
- Implemented a converter for traffic scenarios from OpenDrive.

Application Programming Interface

Features

- Added support for vertical prediction planes to the API.

WRAP 2022.3 Release Notes

The most notable extensions and improvements to WRAP are listed by component.

General

Features

- Updated propagation model ITU-R P.528 to the latest version (version 5).
- Provided an option to include thermal noise in collocation interference calculations.
- Added the ability to display population data in the Map Viewer.
- Added option to display multiple stations in Google Maps / Google Earth after exporting WRAP results to a .kml or .kmz file.
- For LTE communication systems, the effect of MIMO can be included.
- For LTE communication systems that employ multiple transmission modes, WRAP can predict data rates and throughput at any receiver (mobile-station) location based on quantities like minimum required received power and minimum Signal-to-Noise-and-Interference Ratio.
- For LTE telecommunication systems, WRAP can now report key performance indicators such as RSRP, RSRQ and RSSI.
- Improved the calculation accuracy of the location of surface reflections. The improvement will be noticeable when a station is at high altitude.

Resolved Issues

- Fixed a bug in ITU-R P.619 that could sometimes, depending on station height, result in the transmission loss not being computed.
- Refined the criteria that decide which antenna is treated as transmitter and which one as receiver for calculations with ITU-R P.1546-6, in accordance with this ITU recommendation.
- Resolved an issue with the Cost and Coverage Optimiser for population data in raster format.
- Harmonized the handling of situations when a propagation model is used with parameters outside their valid ranges.
- Corrected API message results relevant to creation, modification, usage and deletion of allotments, cables, and stations.

Release Notes: Altair Feko 2022.2.2

Altair Feko 2022.2.2 is available with new features, corrections and improvements. This version (2022.2.2) is a patch release that should be applied to an existing 2022 or 2022.2 installation.

This chapter covers the following:

- [Feko 2022.2.2 Release Notes](#) (p. 79)
- [WinProp 2022.2.2 Release Notes](#) (p. 83)
- [newFASANT 2022.2.2 Release Notes](#) (p. 85)
- [WRAP 2022.2.2 Release Notes](#) (p. 86)

Feko is a powerful and comprehensive 3D simulation package intended for the analysis of a wide range of electromagnetic radiation and scattering problems. Applications include antenna design, antenna placement, microstrip antennas and circuits, dielectric media, scattering analysis, electromagnetic compatibility studies including cable harness modelling and many more.

newFASANT complements Altair's high frequency electromagnetic software tool (Altair Feko) for general 3D EM field calculations, including, among others, special design tools tailored for specific applications like complex radomes including FSS, automated design of reflectarrays and ultra-conformed reflector antennas, analysis of Doppler effects, ultrasound systems including automotive or complex RCS, and antenna placement problems. Advanced solver technologies like the MoM combined with the characteristic basis functions (CBFS), PO/GO/PTD, GTD/PO and MLFMM parallelised through MPI/OpenMP, being some of them especially efficient for the analysis of electrically very large problems.

WinProp is the most complete suite of tools in the domain of wireless propagation and radio network planning. With applications ranging from satellite to terrestrial, from rural via urban to indoor radio links, WinProp's innovative wave propagation models combine accuracy with short computation times.

WRAP is a comprehensive tool for electromagnetic propagation, antenna collocation and spectrum management. WRAP combines propagation analysis, often over large areas with many transmitters and receivers, with system analysis to include complex non-linear equipment properties.

Feko 2022.2.2 Release Notes

The most notable extensions and improvements to Feko are listed by component.

CADFEKO

Features

- Added support for the Cartesian boundary format for near field receiving antennas.
- The idle license check mechanism is suspended when running automation scripts (in interactive or non-interactive mode). This avoids license check errors during long-running scripts.

Resolved Issues

- Resolved an issue with the `.pre` file writing of the SD card where cable shields with admittance definitions were incorrectly using the impedance definition instead.
- Long error and warning messages written to `.pre` files reflecting CADFEKO errors and warnings are truncated to 490 characters.
- The polarity of voltage sources applied to wire ports is correctly maintained when using symmetry planes.
- Resolved an issue where a skin effect was not correctly applied to wire segments on which a port was defined.
- Resolved an issue where splitting closed geometry may have resulted in incorrect regions after the split.
- Waveguide ports are now correctly managed depending on whether they are active, inactive or not referenced by different S-parameter configurations when generating `.pre` files.
- `Pre` file writing for cable interconnects has been corrected for the case where two cable paths terminate at the same connector within the allowed tolerance (maximum dimension of volume containing all cable paths in the model times by $1e-4$).
- Fixed an issue that caused the **Find Clashing Geometry Elements** tool to become unresponsive.
- Allow multiple of the same ports with different rotations for S-parameter requests (this may have caused the conversion of CADFEKO [LEGACY] models to fail).
- Resolved an issue where entities in groups were not correctly labelled when generating the `.pre` file.
- Resolved an issue where previews were not correctly shown for operations (Translate, Rotate, Copy and Translate etc.).
- The model unit is correctly taken into account for predefined cable cross-sections (this may have impacted the conversion of legacy CADFEKO models).
- Fixed the incorrect rendering of the arrows displayed for plane wave sources with non-zero polarisation angle.
- Fixed missing snap points for imprinted points on geometry faces.

- Improved the feedback provided when a region mesh cannot be generated from the bounding surface mesh. The region that failed to mesh is now included in the error message. Users should adjust the mesh settings or the model to obtain a valid mesh.
- Fixed a crash when attempting to create a wire mesh port without first selecting a mesh edge.
- Legacy `.cfx` files that include materials with relative permittivity set to 0.0 will now load successfully. During load, the offending value/s are adjusted to 1e-06 and the user is informed with a warning.
- Fixed a crash when saving a `.pre` file that includes waveguide mesh ports with manually specified modes.
- Updated the **Pre-Process PolIEx REI File** application macro to use the correct syntax when filtering unnecessary via currents in the `.rei` file data.
- Entities may now be selected through a periodic boundary condition visualisation in the 3D view and it is no longer necessary to disable the PBC preview.
- A rendering error resulting in incorrect visualisation of the location of a custom workplane when setting the **Origin** value for far fields has been corrected.
- Fixed a crash that may have been encountered when using snapping for point entry.
- A source is not required for a cable harness when using a **Radiating (taking irradiation into account)** solution.
- Wire ports, network terminals and transmission lines within the label scope of a model decomposition request are correctly reflected in the `.pre` file.
- Fixed keyboard shortcuts using special characters - for example, “#” for **Add Variable**.
- The CADFEKO script editor now correctly detects changes to an open script file and will prompt the user to ask whether the file should be reloaded.
- When converting a nested geometry to primitive, ports and solution settings are no longer incorrectly removed from the geometry.
- The validation of wires in PBC boundary has been corrected. Redundant wires/edges could have been created for geometry and PBC boundary combinations. Matching of faces and edges on the PBC boundaries has been improved to limit the matches to faces in the same part when there are multiple matching entities.
- The correct front and back media for curved mesh faces are included in the `.cfm` file. In some cases, this was incorrect in previous versions.
- Fixed a bug where incorrect mesh size settings would be applied to faces and edges when using symmetry.
- Fixed an assertion that failed when pressing backtick (`) while on the start page.
- Reworked zoom to extents so that all entities currently displayed in the view (including far field and near field request previews) are considered when calculating the zoom factor.
- Point entry for the width of the cuboid primitive has been corrected.
- The correct error message is shown when specifying an invalid `.cfx` file to load from the command line. The script will no longer be run when using the `--run-script` command line option in conjunction with loading an invalid `.cfx` file.
- Improved point entry for the **Axis direction** field when applying a rotate transform on a custom workplane.

EDITFEKO

Features

- Extended the RA card to support the Cartesian boundary format for near field aperture receiving antennas.

POSTFEKO

Resolved Issues

- The detection of far field data in the DRE import application macro has been refined to correctly deal with different degree symbols in the data.

Solver

Features

- Interpolation of Z-parameters from Touchstone data has been improved for some cases.

Resolved Issues

- Reflected rays for near-zero reflection coefficients when using air-like characterised surface materials are no longer discarded in the RL-GO. In some cases discarded rays may have resulted in inaccurate results.
- Added support for parallel simulations using OpenMPI on machines with an NVIDIA GPU.
- Fixed an integer overflow in the allocation of memory that could have resulted in an internal error.
- An error during inter-host communication that may have resulted in error 240 when running with more than one host has been resolved.
- Adjusted the phase reference for the analytical waveguide TE and TM mode field expressions so that the zero phase reference is with respect to the transverse mode field components, rather than the axial mode field components. This ensures a consistent reference between all analytical waveguide port mode types and FEM modal port eigenmodes.
- For iterative techniques, the minimum number of iterations should be at least 5 to avoid premature convergence (this was broken and incorrectly set to 1).
- Resolved a performance regression during the near field to spherical mode transformation phase of a solution of a model with near field sources.

Support Components

Features

- Converted the ideal power divider application macro from the CADFEKO [LEGACY] API to the new CADFEKO API.

- The “Compare CADFEKO Models” application macro is now available in legacy and new CADFEKO.
- The “Load newFASANT Results application” macro in POSTFEKO now fully supports near fields and RCS results.
- Added a how-to in the Feko User Guide on interpreting far fields calculated from a PBC solution.

Resolved Issues

- Resolved an issue with the generate array macro in CADFEKO so that amplitude tapering is correctly applied in both X and Y directions of the array where relevant.
- Resolved an error where `.fhm` files generated by specific versions of Altair HyperMesh may have resulted in an “unsupported card ” error.
- Resolved an error when parsing CST NFS data.

WinProp 2022.2.2 Release Notes

The most notable extensions and improvements to WinProp are listed by component.

ProMan

Features

- Diversity gain, of multiple mobile station antennas, is now considered during network planning in ProMan.
- Corrected the calculation of the breakpoint distance in the Empirical Two-Ray Model. It is now calculated from the last diffraction point instead of from the transmitter.
- Improved the multi-threaded performance of the mechanism used to write results as well as log simulation progress. This stage was a performance bottleneck in previous versions when simulating projects with many transmitters using a large number of threads.
- Added an option to control the display of graphical elements (objects and entities not used in the simulation) in indoor projects.

Resolved Issues

- Corrected the RSRQ calculation for LTE scenarios with traffic load less than 100%.
- Corrected a case in calculation of rays scattered off a very rough surface where power scaling based on scattering tile size was not properly applied.
- Resolved an issue with the superposition of rays in a fully polarimetric project that uses Fresnel coefficients.
- The vertical knife edge diffraction in rural projects has been improved to create fewer diffraction points over rounded terrain profiles, especially when used in combination with the deterministic two-ray propagation model.
- The total gain is now used for non-polarimetric projects with `.ffe` pattern files at the transmitter.
- The `Antenna RayProfile.txt` result file in the `MS Results` folder now reports power values received at the mobile station.
- Fixed situations in which a change in calculation parameters did not invalidate previous results.
- Corrected the statistics information displayed for multi layer projects.
- Results are now disabled in the result tree of ProMan if parameters related to the database are modified.
- Added support for arbitrary angular ranges of transmitters consisting of antenna patterns read from `.ffe` files.

WallMan

Resolved Issues

- Fixed a bug that gave the third coordinate of the 2D views the wrong sign.

AMan

Resolved Issues

- Added support for arbitrary angular ranges of transmitters consisting of antenna patterns read from .ffe files.

Application Programming Interface

Features

- Improved the multi-threaded performance of the mechanism used to write results as well as log simulation progress. This stage was a performance bottleneck in previous versions when simulating projects with many transmitters using a large number of threads.

Resolved Issues

- Improved the display of network planning results 3D view for projects with prediction planes computed using the API.

newFASANT 2022.2.2 Release Notes

The most notable extensions and improvements to newFASANT are listed by component.

GUI

Resolved Issues

- A change was made to the installed configuration file to avoid problems on some systems where the GUI components of newFASANT did not start correctly.

General

Features

- The **Load newFASANT Results** application macro in POSTFEKO now fully supports near fields and RCS results.

WRAP 2022.2.2 Release Notes

The most notable extensions and improvements to WRAP are listed by component.

General

Features

- Enhanced the API to include a Status field for stations and equipment.

Resolved Issues

- Corrected one of the atmospheric attenuation settings for propagation models used in the Interference tool.
- Added time-availability to the ITU-R P.617 propagation model. Fixed an incorrect calculation of the tropospheric scattering angle in the ITU-R P.617 propagation model.

Release Notes: Altair Feko 2022.2.1

Altair Feko 2022.2.1 is available with new features, corrections and improvements. This version (2022.2.1) is a patch release that should be applied to an existing 2022 or 2022.1 installation.

This chapter covers the following:

- [Feko 2022.2.1 Release Notes](#) (p. 88)
- [WinProp 2022.2.1 Release Notes](#) (p. 92)
- [newFASANT 2022.2.1 Release Notes](#) (p. 93)
- [WRAP 2022.2.1 Release Notes](#) (p. 94)

Feko is a powerful and comprehensive 3D simulation package intended for the analysis of a wide range of electromagnetic radiation and scattering problems. Applications include antenna design, antenna placement, microstrip antennas and circuits, dielectric media, scattering analysis, electromagnetic compatibility studies including cable harness modelling and many more.

newFASANT complements Altair's high frequency electromagnetic software tool (Altair Feko) for general 3D EM field calculations, including, among others, special design tools tailored for specific applications like complex radomes including FSS, automated design of reflectarrays and ultra-conformed reflector antennas, analysis of Doppler effects, ultrasound systems including automotive or complex RCS, and antenna placement problems. Advanced solver technologies like the MoM combined with the characteristic basis functions (CBFS), PO/GO/PTD, GTD/PO and MLFMM parallelised through MPI/OpenMP, being some of them especially efficient for the analysis of electrically very large problems.

WinProp is the most complete suite of tools in the domain of wireless propagation and radio network planning. With applications ranging from satellite to terrestrial, from rural via urban to indoor radio links, WinProp's innovative wave propagation models combine accuracy with short computation times.

WRAP is a comprehensive tool for electromagnetic propagation, antenna collocation and spectrum management. WRAP combines propagation analysis, often over large areas with many transmitters and receivers, with system analysis to include complex non-linear equipment properties.

Feko 2022.2.1 Release Notes

The most notable extensions and improvements to Feko are listed by component.

CADFEKO

Features

- Added an option to improve rendering speed at the cost of visual quality. This option can be useful when working with large or detailed models for better application responsiveness.
- Extended the mesh info dialog to include edge length information for tetrahedra.

Resolved Issues

- Corrected the model status validation and `.pre` file writing for RL-GO faces with coatings.
- Fixed a rendering issue that would result in geometry having erroneous spiky triangles.
- Resolved a crash where a union operation involved a modification to the face of a waveguide port.
- An "index out of range error" avoided during conversion of some Legacy `.cfx` files.
- Resolved a problem where coatings applied to model mesh segments were not written out to the `.pre` file. Coatings on mesh segments were not taken into account during simulation and were not present when viewing the model in POSTFEKO.
- Corrected a `.pre` file writing bug where the region medium referenced by waveguide ports could have been written out incorrectly.
- Corrected `.pre` file writing where loads were not correctly reset in all cases. The problem presented for models containing multiple configurations with the the same frequency setting where the loads differ between the first and last configuration.
- Options were added to the **Solver Settings** dialog to request additional debug output from RUNFEKO, OPTFEKO and ADAPTFEKO. This adds the `-d` option when launching the relevant Feko component.
- Added validation to prevent the creation of extremely small complex surfaces. Previously, this could have caused the application to crash.
- Fixed a problem when using the **Tetrahedral mesh** definition method for near fields that the simulation would calculate a single Cartesian near field point. The selected definition method is now correctly reflected in the FE card in the `.pre` file written out by CADFEKO and correctly transferred to the solver.
- Fixed a problem where nearby parts would be meshed together, causing an unexpected recalculation of the mesh even when changing settings that should not cause a recalculation to be triggered (for example changing global mesh settings when the part has local mesh settings applied). This bug could also have caused mesh settings of the one part being applied to the other part.
- Adjusted the curvature mesh settings slightly. This will most likely result in fewer mesh elements for models where curvature dominates the element size calculation.
- Improved performance during a union operation on larger models.

- Improved application usability during rendering.
- Removed validation that prevented activation of **Remote** launching of the Solver when host names were not yet defined.
- Added missing support for wires when defining model decomposition requests.
- Fixed `.cfm` file writing for mesh regions.
- Resolved an issue where importing Unigraphics/NX files resulted in no geometry. Unigraphics/NX files can now be imported.
- Corrected validation for transmission lines and general networks to take connections outside of the schematic view into account. A model status error was erroneously issued indicating that the network component needed connections when it was used in an S-parameter request or connected to a voltage source or a load.
- Fixed a bug that could have resulted in a critical error when finding distorted or oversized elements if the model has invalid or incomplete simulation meshes.
- Corrected the standard deviation and tetrahedral mesh information on the **Mesh info** dialog.
- Introduced stricter validation that prevents the creation of coincident points to avoid a crash when creating complex surfaces.
- Improved the startup time of new CADFEKO. Also improved loading and closing times of models with meshes containing large numbers of mesh elements.
- Renamed **Include Cutout Layer** to **Include Board Outline**, changed the default PCB import type to ODB++ and unchecked import of solder resist and board outline layers by default.
- Added the missing **Field/Current Data** context menu entry for **Import Solution Coefficient Data**.

EDITFEKO

Resolved Issues

- Resolved a regression introduced in a previous version where the generic aperture option for a FEM modal port was not available at the MB card.

POSTFEKO

Features

- The DRE import has been extended to support near-fields in a cylindrical coordinate system.
- Added the option to choose the **Plane Wave Theta**, **Plane Wave Phi** or **Polarisation angle** axes as independent axis for characteristic mode results plotted on a Cartesian graph.

Resolved Issues

- Corrected the header written out to `.dat` file when exporting data from a surface graph to show the correct unit.
- Fixed a crash that could be encountered when deleting 2D text and shapes from 2D graphs.

- Fixed the export of `.efe` and `.hfe` files to use the correct capitalisation for axis names so that these files can be interpreted correctly by PREFEKO.
- Improved the handling of custom imported data containing axes in radians. The values are now correctly converted to degrees when plotting the data on a Cartesian or polar graph and using trace maths.

Solver

Features

- Improved the accuracy of the ray tracing phase of a Faceted UTD simulation for some models.
- General speed improvements were made to the implementation of the faceted UTD and parallel scaling was improved.
- Accelerated the ray tracing of the wedge diffraction phase of faceted UTD solutions.

Resolved Issues

- For the MLFMM run with MPI, only switch to out-of-core MUMPS with the hybrid MPI/OpenMP approach introduced with Feko 2022.2 if it is estimated that this will lead to a sufficient reduction of in-core memory to compute the numerical factorisation. Continue in-core otherwise, since out-of-core can have a severe performance penalty.
- Resolved a deadlock that occurred during a the preconditioning phase of a parallel MLFMM simulation on a machine with low hard disk space.
- Resolved an issue with the spatial-peak SAR calculation in a model having both MoM and FEM.
- Improved the performance of the solution preparation phase of an RL-GO simulation of models with a large number of observation points.
- Fixed a bug in the calculation of the normal vectors to the aperture faces of a Cartesian boundary near field receiving antenna. A consistent outward normal should be used.
- Corrected the reported memory requirements of the equivalent MoM matrix when solving a model using ACA.

Shared Interface Changes

Resolved Issues

- Fixed an issue where some PDF viewers on Linux could not be launched from the GUI components.
- Corrected the structure for the far field values written to the `.mcr` file by the multiport processor.
- Re-added support for sharing component launch option settings between applications.

Support Components

Features

- Added the export of annotation data from a polar and Cartesian graph to the HyperStudy extraction script. This allows values from annotations on POSTFEKO graphs to be used as values for optimisation without additional maths and setup in HyperStudy.
- Updated example C5 in the Example Guide to use the new periodic structures features in CADFEKO.
- Added auto-detection for near fields in a cylindrical coordinate system to the **Import DRE** application macro.
- Corrected a figure in the Feko User Guide that shows how to define a mask for optimisation. The values filled in on the dialog did not reflect that the frequency for the example was in GHz.
- Restored the **Create Rough Sea Surface** application macro to CADFEKO.

Resolved Issues

- Fixed the loading of CADFEKO models on Linux for the getting started GS4 and example guide A11.1 and A11.2 macros.
- Corrected expression evaluation for the inputs for the **Parameter Sweep: Create Models** application macro so that inputs no longer need to be numeric, but can include expressions.
- Added validation to detect if there are missing result files (.bof) before combining the data for a parameter sweep run. The missing files are ignored, and the available data is merged as normal.
- Added validation in the **Parameter Sweep: Create Models** application macro to report an error if the model path contains utf8 characters.
- Added validation the HyperStudy-Feko interface so that if meshing fails (for example if legacy CADFEKO is incorrectly called using an incompatible CADFEKO model) error feedback is given.

WinProp 2022.2.1 Release Notes

The most notable extensions and improvements to WinProp are listed by component.

ProMan

Features

- Antenna phase is now considered for transmitters in the `.apa` format.

Resolved Issues

- Improved the stability of SBR predictions by eliminating a rare local randomness in ordering of scattered rays.
- Resolved an issue that may sometimes lead to the application hanging after cancelling a multi-threaded indoor IRT prediction.
- Resolved an issue that led to a mismatch between field strength values associated with rays and the received power computed at a mobile station for some full polarimetric projects.
- Resolved an issue related to moving time-variant objects when a value of zero is assigned to the velocity of two or more consecutive steps of an object's dynamics.
- Ray information can now be displayed for all time steps in a time-variant urban project.
- Resolved an issue with the format of ASCII network-planning results in projects with multiple prediction trajectories.
- Reactivated the writing of a results log file.

WallMan

Resolved Issues

- Resolved a crash during conversion of a GeoTIFF database where the y-coordinate of the lower-left corner is larger than that of the upper-right corner.

AMan

Resolved Issues

- Resolved a bug that could result in inaccurate beam elevation when forming a 3D pattern from a vertical and a horizontal 2D pattern using `.msi` files.
- Improved the accuracy of generated antenna beams and envelope patterns when large elevation angles were requested.

newFASANT 2022.2.1 Release Notes

The most notable extensions and improvements to newFASANT are listed by component.

Solver

Resolved Issues

- Resolved an issue that could affect bistatic RCS calculation for certain points within the GTD-PO module.

WRAP 2022.2.1 Release Notes

The most notable extensions and improvements to WRAP are listed by component.

General

Features

- Set the default clutter option for the **Aeronautical Interference** tool to “No extra clutter loss” to avoid long computation times.
- Accelerated the time diagram calculations for satellites.

Resolved Issues

- Fixed a bug that could reduce the resolution of the maps and results when the Global Human Settlement population database was used.
- Corrected the determination of the path type (terrestrial/spatial) in the Interference tool for satellites.
- Corrected the EER value for the ITU-R P.452 model when Worst-month prediction is selected.
- Updated API messages with TgTuRatio element where thus far the old element TgTsRatio had been used.

WRAP MapDataManager

Features

- Added an error message for attempted conversion of GeoTIFF raster data with unsupported very-high resolution. Support for higher resolutions may be added in the Feko 2023 release.

Resolved Issues

- Fixed an incorrect DTED conversion of negative values.

WRAP CoordMan

Resolved Issues

- Added a confirmation window when the default country is changed.

Altair Feko 2022.2 is available with new features, corrections and improvements. It can be applied as an upgrade to an existing 2022.1 installation, or it can be installed without first installing Altair Feko 2022.1.

This chapter covers the following:

- [Highlights of the 2022.2 Release](#) (p. 96)
- [Feko 2022.2 Release Notes](#) (p. 101)
- [WinProp 2022.2 Release Notes](#) (p. 106)
- [WRAP 2022.2 Release Notes](#) (p. 107)

Feko is a powerful and comprehensive 3D simulation package intended for the analysis of a wide range of electromagnetic radiation and scattering problems. Applications include antenna design, antenna placement, microstrip antennas and circuits, dielectric media, scattering analysis, electromagnetic compatibility studies including cable harness modelling and many more.

newFASANT complements Altair's high frequency electromagnetic software tool (Altair Feko) for general 3D EM field calculations, including, among others, special design tools tailored for specific applications like complex radomes including FSS, automated design of reflectarrays and ultra-conformed reflector antennas, analysis of Doppler effects, ultrasound systems including automotive or complex RCS, and antenna placement problems. Advanced solver technologies like the MoM combined with the characteristic basis functions (CBFS), PO/GO/PTD, GTD/PO and MLFMM parallelised through MPI/OpenMP, being some of them especially efficient for the analysis of electrically very large problems.

WinProp is the most complete suite of tools in the domain of wireless propagation and radio network planning. With applications ranging from satellite to terrestrial, from rural via urban to indoor radio links, WinProp's innovative wave propagation models combine accuracy with short computation times.

WRAP is a comprehensive tool for electromagnetic propagation, antenna collocation and spectrum management. WRAP combines propagation analysis, often over large areas with many transmitters and receivers, with system analysis to include complex non-linear equipment properties.

Highlights of the 2022.2 Release

The most notable extensions and improvements to Feko, newFASANT, WinProp and WRAP in the 2022.2 release.

Salient Features in Feko

- A new **Periodic Structures** extension has been added to CADFEKO. This extension supports the preparation of structures such as those used in frequency selective surface (FSS) simulations. The new shapes, geometry and unit-cell tool can be used to quickly define both simple and complex parametric multi-layer unit-cell representations of multi-layer dielectric structures which may include FSS layers for material characterisation using a periodic boundary condition approach. Characterised materials can in turn be applied to surfaces for efficient simulation using RL/GO methods. With Feko 2022.2 it is also possible to apply such characterised materials to surfaces bounding a closed region and solve using the MoM/MLFMM. This provides an extremely powerful, flexible and efficient approach to applications such as radome analysis.

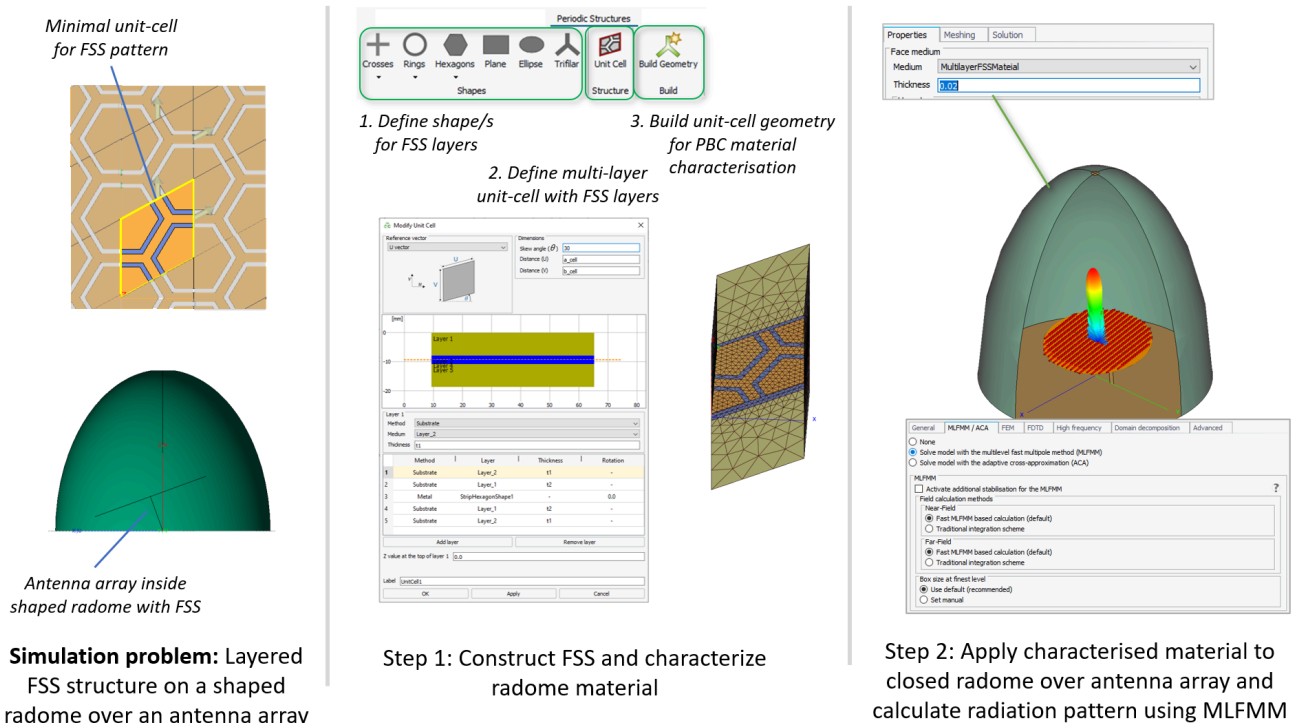

Figure 21: A streamlined and flexible workflow for simulation of multi-layer FSS radome structures using material characterisation with PBC and MoM/MLFMM.

- The waveguide port and sources were extended and can now also be applied to a single flat face on the boundary of a FEM region in CADFEKO in the same way as is done for SEP. This simplifies the process of switching between SEP and FEM for models using waveguide ports. Waveguide ports now support an additional power-based definition of magnitude which is common to all mode types and may be more intuitive.

- S-Parameter configurations in CADFEKO may now include additional requests (such as far field, near field and current requests) and separate configuration/s are not needed. These quantities will be computed as part of the solution for each port that is active during the S-Parameter simulation.
- Four new components were added to the **Component Library**. These are horn-fed reflector antennas as well as a dual-mode horn which may be used to provide more uniform illumination of a reflector than would be achieved with a simple conical horn.

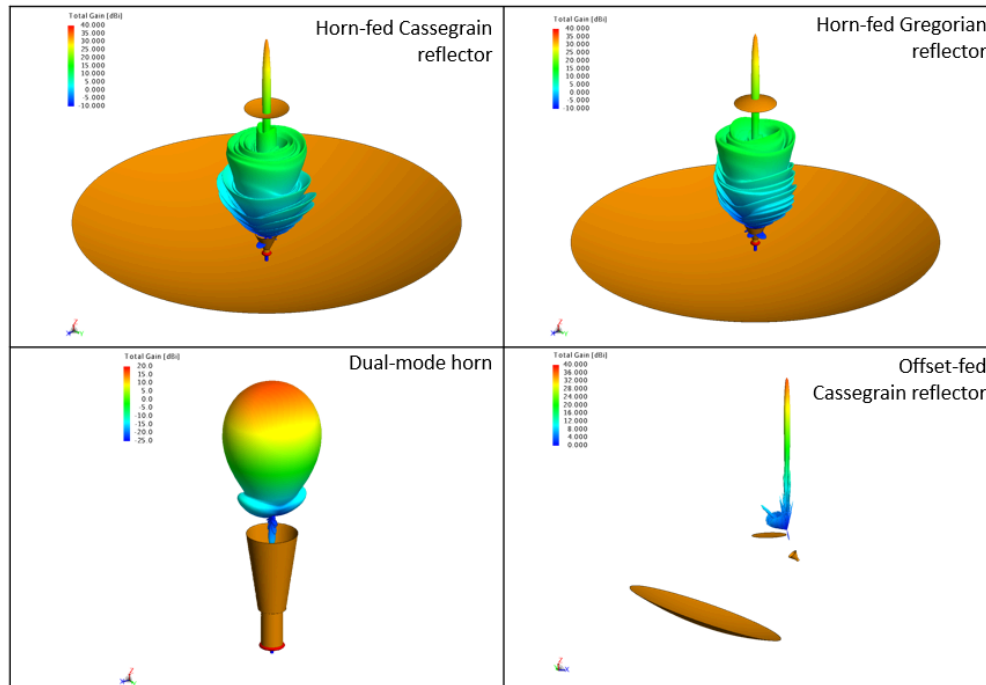

Figure 22: The four new components added to the Component Library.

- The ray search process in the faceted UTD has been accelerated significantly. In isolated cases assumptions may result in small errors and an option is available to deactivate this acceleration feature should this impact on the accuracy of a specific solution.
- PCB Import in CADFEKO now supports material properties that may be included in the imported PCB layout or ECAD data. The relevant materials will be created and applied during the import process. Additional layer types (such as solder-resist, solder-paste, silkscreen and user-defined layers) may also now be imported if required. Layers of a specific type may be included/excluded using simple bulk options on the import dialog.

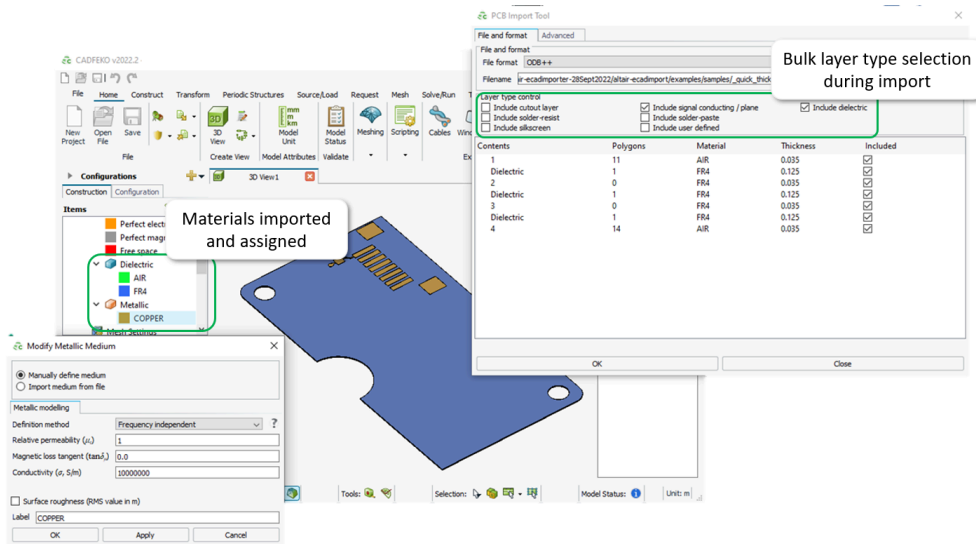

Figure 23: During import of PCB formats materials are included and assigned. In addition bulk include/exclude of layer types is supported.

- The boundary of a **PCB Current Source** is now shown in the 3D view in CADFEKO allowing the PCB source to be accurately positioned and visualised. A new **Feko Source Data Viewer** has been added to the context menu of **PCB Current Data** definitions. In this viewer, details of the currents in the PCB source can be viewed for each frequency, layer and net included in the **PCB Current Data**.

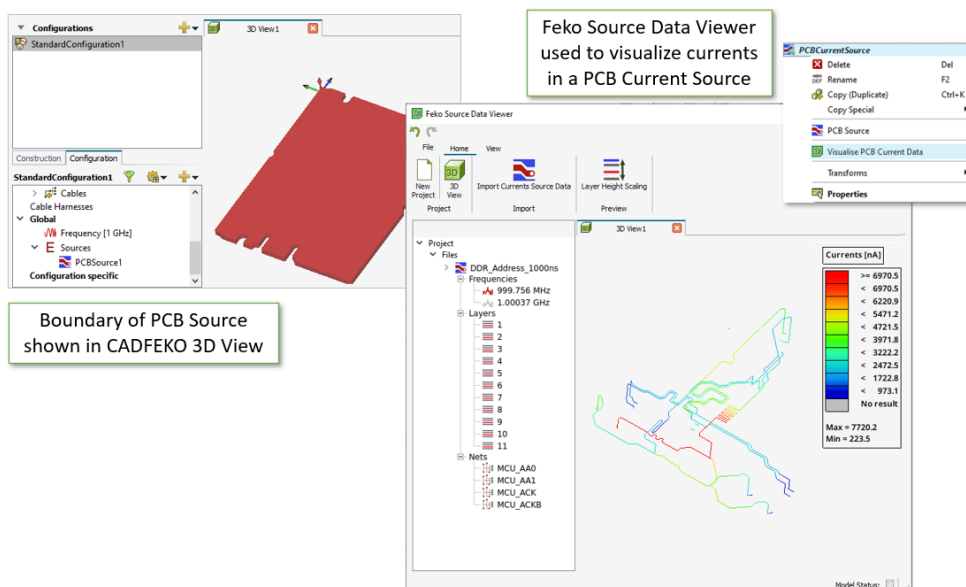

Figure 24: Viewing the boundary of a PCB Source and using the **Feko Source Data Viewer** to view the currents included in a PCB source at a chosen frequency.

Salient Features in WinProp

- Added support for X-polarization of the base and mobile station antennas. In previous versions, ProMan used to require you to define two transmitters explicitly. Now only one transmitter needs to be defined with X-polarization while ProMan handles the rest. This saves you significant time when setting up a network-planning project with many base stations.
- Added support in WallMan for building data in the CityGML (.gml, .citygml) format. The CityGML converter is a popular format used by many free-of-charge sources of city building data.

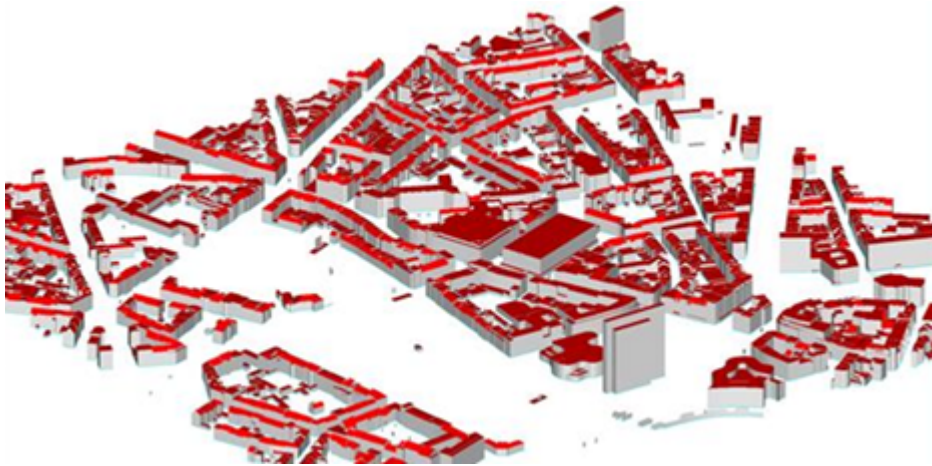

Figure 25: An example of building data converted using the CityGML converter in WallMan.

- Added the option to include explicitly the ground-reflected ray and roof-reflected rays in urban propagation computations with Intelligent Ray Tracing. Including the multipath makes the computation more accurate than using the approximation via breakpoint effect.

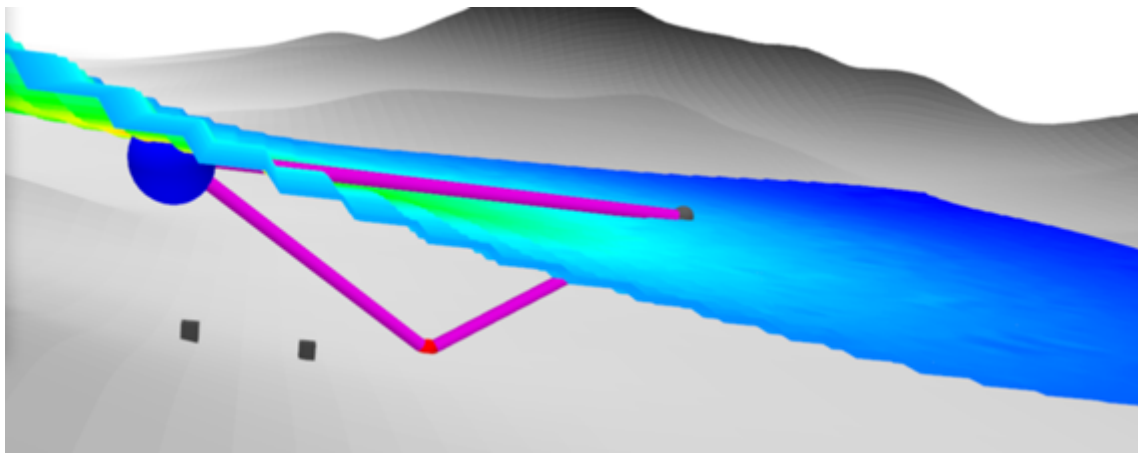

Figure 26: An example of a ground-reflected ray using Urban Intelligent Ray Tracing.

Salient Features in WRAP

- Added support in WRAP to import population data from the Global Human Settlement database. The Global Human Settlement database has world-wide population data with a resolution as fine as 250m and is important for network capacity planning.

- Updated two ITU propagation models to the most recent versions published by the ITU:
 - *ITU-R P.619*

The P.619 model is important for satellite communication and satellite coverage. The new version includes terrain in the simulations while the old version did not. Simulations will be more accurate but require more memory and runtime.

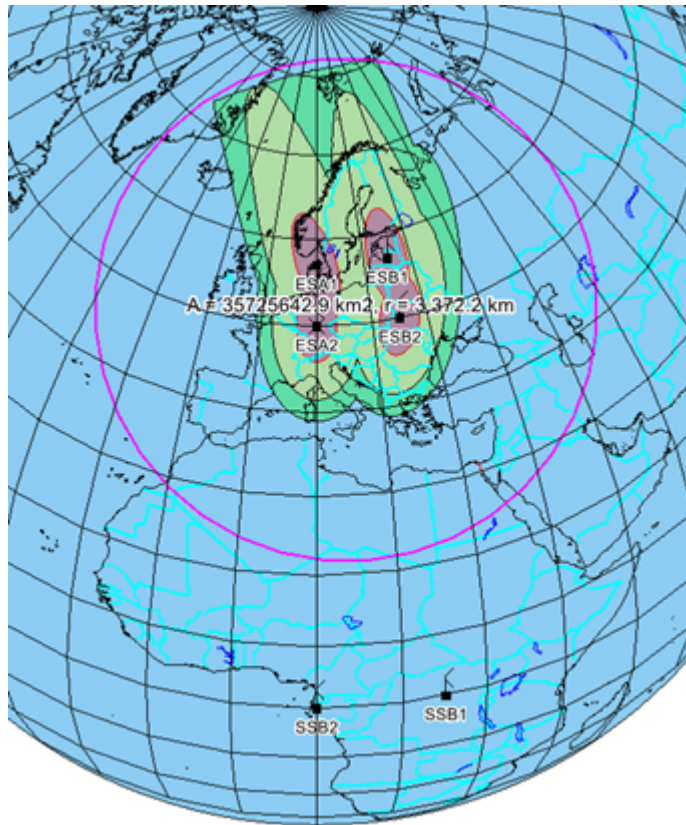

Figure 27: An example of satellite communication and coverage.

- *ITU-R P.528*

The P.528 model is important for aeronautical mobile and radio navigation services. The new version mandates calculations based on equations while the old version used tabulated data. Simulations will be more accurate but require more computer time. The old version remains accessible as an option.

Feko 2022.2 Release Notes

The most notable extensions and improvements to Feko are listed by component.

CADFEKO

Features

- Extended the geometry waveguide port and the waveguide source to be used in conjunction with analytical waveguide excitations supported in the FEM solution method.
- Added support for power-based definition of magnitude for waveguide ports. This definition is more intuitive than the one previously used and is common to all mode types. Select the **Use legacy magnitude convention** check box on the **Create Waveguide Port** dialog (**Advanced** tab) to use the legacy definition of mode-dependent units.
- Introduced new geometry surface primitives for constructing periodic structures. These allow for quick parametric definition of multilayer unit cell structures using diverse shapes. Unit cells can be used for material characterisation in a periodic boundary condition simulation.
- Extended S-parameter configurations to support field and current requests. This allows the fields and currents to be calculated for each excited port (excited at one port at a time).
- Extended S-parameter requests with an option to export the files required to do multiport post-processing.
- Upgraded the CAD import library to support the latest CAD file versions.
- Improved PCB imports in the following ways:
 - Collective layer types, grouped by media or other physical properties, can now be included or excluded during import.
 - Solder-resist, solder-paste, silkscreen and user-defined layers are now supported.
 - Material properties defined in the imported PCB file will now be defined and applied during import.
 - Introduced options on the the advanced tab to **Simplify** and/or **Union** the resultant geometry during PCB import.
- Board outlines of PCB sources are now displayed in the 3D view.
- The new **Feko Source Data Viewer** application can be launched from the context menu of **PCB Current Data** definitions. The currents can be viewed per frequency.
- Export of CATIA V5 is now supported on Linux.
- Added an option to import media from the **Altair Material Data Center**. The **Material Database** will be populated over time with materials that can be used in Feko simulations.
- Extended the face properties dialog to allow applying characterised surface coatings to closed regions solved with the MoM/MLFMM.
- Added a verification message for models containing faces with settings that are only valid when the faces form a closed surface. The combined field integral equation and magnetic field integral equation should only be applied to faces that bound closed regions. Similarly, characterised surface coatings can only be applied on faces of closed regions.

- Extended the solver settings dialog to support the new **Auto** low frequency stabilisation option.
- Added an option to enable or disable accelerations for the faceted UTD to the **Solver Settings** dialog.
- Extended the project filter with the option to apply the filter to the 3D view. Before, the project filter only filtered items in the tree.
- Removed the ability to **Show Only in Collection** to avoid confusion. The same behaviour can be achieved by using **Show Only** or toggling **Show/Hide**.
- Improved the performance of volume meshing by ensuring that volume meshes are always meshed with near-isotropic elements.
- Extended mesh refinement rules with the options to **Show/Hide** individual rules in the 3D view and to **Include/Exclude** rules to control whether they influence meshing.
- Extended adaptive mesh refinement control allowing the maximum threshold level to be set. A value of 1.0 was used in previous versions. Using the **ErrorLevelThresholdMaximum** and the **ErrorLevelThreshold** properties, mesh refinement ranges can be set.
- Added the **Create Wireless Communication Measurement Configuration** application macro in CADFEKO. This macro adds a standard configuration with the specified frequency range and far field request and can suggest the required angular increment for the far field request to have the correct sampling for the far field data when used in post-processing with the **Calculate Wireless Communication Performance** application macro in POSTFEKO.
- Converted the following application macros to the new CADFEKO API:
 - Farm Model to Cluster
 - Create Frequency Ranges
 - Create Far Field Equivalent Sources Split Over Frequency

Resolved Issues

- Resolved a hang when a union failed and a crash when a union failed during PCB import.
- Added error messages when using `.dxf` and Unigraphics/NX imports as they are currently unsupported.
- Added an error message when a geometry import results in no geometry.
- Resolved an issue where using **Show Only** on a sub-part caused it to be shown only while selected.
- Resolved an issue where it was rarely possible to select a region through a hidden region in the 3D view.
- Resolved a problem that prevented the display of volume meshing progress.
- Added icons to mesh tetrahedron regions in the details tree.
- For the case where a PEC face lies on a periodic boundary, bounds a PEC region and has a matching PEC face on the opposite PBC boundary, an error is no longer incorrectly shown in the model status panel.
- Resolved an issue where the links on the start page did not work on server installations.
- Resolved the issue that the `configure-script` command line argument did not work when launching the new CADFEKO.

- Resolved a crash when using the **Cancel** button on a Lua form if the button triggered an assert in the callback function.
- Resolved an issue with the **Generate Antenna Array** application macro that would end in an error when there are global loads and sources in the model.
- The correct number of layers is now created in the multilayer Green's function when creating the PCB stack-up in the **Pre-Process PolEx Rei file** application macro.

EDITFEKO

Features

- Added support to the AW (waveguide port) card for power-based definition of magnitude. This definition is more intuitive than the one previously used and is common to all mode types. Select the **Use legacy magnitude convention** check box to use the legacy definition of mode-dependent units.
- Added support to the CO card (for coatings) to define a characterised surface coating. This type of coating is supported for closed regions solved with the MoM/MLFMM solver.
- Extended the DA card (for writing additional data files) with an option to export the files required for multiport processing.
- Extended the EG card (that indicates the end of the geometry input) to support the new **Auto** low frequency stabilisation mode.
- Added support to the UT card to enable acceleration for faceted UTD. This acceleration technique is enabled by default and speeds up the search of the geometry significantly, but it might result in some rays not being found in exceptional cases. This option allows you to disable this feature at the expense of a runtime increase.

POSTFEKO

Features

- Added support for viewing impedance and other results for single port S-parameter request configurations when the S-parameter configuration also includes a near field, far field or currents request.
- Added support for characterised surface coatings on faces. The orientation of the specified reference direction as well as faces with this type of coating can be visualised in the 3D view.
- Annotations on 2D graphs can be added, modified and removed from the scripting environment.
- Added support for surface graphs to the **Copy Graph Formatting** application macro.
- Added the **Calculate Wireless Communication Performance** application macro to POSTFEKO. The macro calculates the effective isotropic radiated power (EIRP), effective isotropic sensitivity (EIS), total radiated power (TRP) and total isotropic sensitivity (TIS) from a far field data set. Use this macro with the **Create Wireless Communication Measurement Configuration** application macro in CADFEKO to get the correct sampling for the far field.

Resolved Issues

- Resolved the issue where a TG card that was manually inserted into the `.pre` to translate the model could cause an assertion to fail when loading the associated `.bof` file.
- Corrected the active port indices displayed for results associated with S-parameter configurations with inactive ports.
- Fixed a recent regression introduced in version 2022.1.1 that caused a problem with the display of named point labels in the 3D view.
- Text box elements added to 2D graphs will now correctly update when modifying them from the scripting environment.
- Resolved an issue where the **Import Winprop Trajectory Results** application macro would fail when importing results that included log files.

Solver

Features

- Discontinued MPICH support on Windows.
- Improved the performance of the iterative solution phase of an MLFMM simulation. Performance gains of ~15% are achievable on Intel CPUs.
- Added support for the OpenMPI message passing interface. This can be selected using the `FEKO_WHICH_MPI = 15` environment variable in `FEKOEnvironment.lua` and can not be used on machines with CUDA installed.
- SPICE circuit files can now be exported in a user-specified SPICE syntax (NGSPICE/LTSPICE/PSPICE), using the `--mtl-circuit-export` directive, without requiring the SPICE executable to be available.
- Various optimisations have been made to the faceted UTD solver which will provide accurate results but require less memory and runtime. In some cases the optimisations may result in small differences when compared to the solutions generated using rigorous UTD. Should the rigorous solution be needed, the optimisations can be deactivated using the High Frequency Solver Settings in CADFEKO or on the UT card in EDITFEKO.
- Improved the performance of sequential simulations of models with impressed near field sources.
- Added support for modelling of coatings using characterised surfaces.
- Extended the model decomposition framework by adding support for wires in the exported `.sol` file.
- When the estimated memory requirement for preconditioning exceeds the available memory during an MLFMM run with MPI, an intermediate approach using hybrid MPI/OpenMP is first considered, before switching to an out-of-core solution. In some cases, this may enable better use of the available memory and avoid running out-of-core.
- Corrected the source power calculation for models with equivalent sources and infinite ground plane.
- Memory limitation set through the `PAS_MEMORY` variable, on PBS job schedulers, is now also taken into account as the maximum allowable memory of a Feko run launched through such a job. This

has implications on how certain phases of a solution are executed. For instance, an out-of-core solution could be triggered depending on the value of PAS_MEMORY.

Shared Interface Changes

Feature

- Increased the `.fek` file version to 189 to accommodate new features.

WinProp 2022.2 Release Notes

The most notable extensions and improvements to WinProp are listed by component.

General

Features

- Upgraded many third-party libraries.

ProMan

Features

- Added the option to include explicitly the ground-reflected ray and roof-reflected rays in urban propagation computations with Intelligent Ray Tracing.
- Accelerated point mode predictions in rural scenarios through parallelisation across prediction points.
- Added the possibility to set the minimum wedge length as well as the maximum inner angle between wedges to be considered during indoor predictions with the DPM.
- Added support for X-Polarization of the base and mobile station antennas.

WallMan

Feature

- Added support for database conversions in the `.citygml` format.

AMan

Resolved Issue

- Resolved a bug that could result in inaccurate beam elevation when forming a 3D pattern from a vertical and a horizontal 2D pattern using `.msi` files.

WRAP 2022.2 Release Notes

The most notable extensions and improvements to WRAP are listed by component.

General

Features

- Added support for displaying cursor values of line results.
- Added the option to duplicate a station's antenna, in order to create easily multiple antennas on one station.
- Added a Filter capability to the Select Template Station dialog to facilitate searching in the list of station templates.
- Updated propagation model ITU-R P.619 to the latest version (version 5).
- Added options to specify distance in nautical miles and altitude in feet, the preferred units in nautical and aeronautical applications.
- Enabled WRAP to use data from the Global Human Settlement population database.
- Added support for using Active Directory for login rather than the WRAP login interface.

Resolved Issues

- Resolved a crash when using the broadcast tool in a project with a station that isn't a receiver.
- Resolved an issue with importing a certain class of .kml files (with internal multi-geometry tag) in the map window.
- Added the Extended Two-Ray model to the propagation-model advisor.

WRAP SAM

Feature

- WRAP Spectrum Allocation Manager now requires six Altair Units, down from 21.

WRAP MapDataManager

Resolved Issue

- Fixed an incorrect DTED conversion of negative values.

Release Notes: Altair Feko 2022.1.3

11

Altair Feko 2022.1.3 is available with new features, corrections and improvements. This version (2022.1.3) is a patch release that should be applied to an existing 2022 or 2022.1 installation.

This chapter covers the following:

- [Feko 2022.1.3 Release Notes](#) (p. 109)
- [WinProp 2022.1.3 Release Notes](#) (p. 111)
- [newFASANT 2022.1.3 Release Notes](#) (p. 112)

Feko is a powerful and comprehensive 3D simulation package intended for the analysis of a wide range of electromagnetic radiation and scattering problems. Applications include antenna design, antenna placement, microstrip antennas and circuits, dielectric media, scattering analysis, electromagnetic compatibility studies including cable harness modelling and many more.

newFASANT complements Altair's high frequency electromagnetic software tool (Altair Feko) for general 3D EM field calculations, including, among others, special design tools tailored for specific applications like complex radomes including FSS, automated design of reflectarrays and ultra-conformed reflector antennas, analysis of Doppler effects, ultrasound systems including automotive or complex RCS, and antenna placement problems. Advanced solver technologies like the MoM combined with the characteristic basis functions (CBFS), PO/GO/PTD, GTD/PO and MLFMM parallelised through MPI/OpenMP, being some of them especially efficient for the analysis of electrically very large problems.

WinProp is the most complete suite of tools in the domain of wireless propagation and radio network planning. With applications ranging from satellite to terrestrial, from rural via urban to indoor radio links, WinProp's innovative wave propagation models combine accuracy with short computation times.

WRAP is a comprehensive tool for electromagnetic propagation, antenna collocation and spectrum management. WRAP combines propagation analysis, often over large areas with many transmitters and receivers, with system analysis to include complex non-linear equipment properties.

Feko 2022.1.3 Release Notes

The most notable extensions and improvements to Feko are listed by component.

CADFEKO

Features

- Added support for Parasolid geometry import of files with `.xmt_txt`, `.xmt_bin`, `.p_b`, `.p_t`, `.xmp_bin` and `.xmp_txt` extensions.
- Added a Cassegrain Reflector Antenna to the Component Library.
- A Dual-Mode Horn Antenna component has been added to the Component Library.
- Added a Gregorian Reflector Antenna to the Component Library.
- Added an Offset Cassegrain Reflector Antenna to the Component Library.

Resolved Issues

- When opening a legacy CADFEKO model that includes cable bundles using auto-bundling, the correct bundling approach will be used.
- Resolved a problem with the handling of multiple configurations where the previous configuration contains a superset of the loads or excitations in the current configuration. Loads and excitations were not cleared correctly between these configurations and would incorrectly be included in the subsequent configuration. The problem affected results and would be observed as additional, unexpected loads in POSTFEKO.
- Fixed a bug that could cause a hang or a crash when clicking the **Browse** button on file and folder browsers in a Lua form.
- Fixed a bug that made the notes view not editable from the keyboard.
- Fixed view anchoring for rotating scaled model meshes in the 3D view.
- Fixed view anchoring for rotating parts while on **Simulation Mesh** display mode.
- Improved crash feedback so that a dialog is displayed instead of the application silently closing.
- Improved the meshing of structures which include long, curved edges (such as helices). Also improved the impact of advanced meshing options for refinement factor and minimum element size when meshing these types of models.

POSTFEKO

Resolved Issues

- Resolved an issue that caused an assertion to fail when enabling the mesh visibility options for tetrahedral edges or volumes in large models with over 110 000 000 mesh elements.

Solver

Resolved Issues

- Resolved an issue that incorrectly triggered errors for some models including FEM line ports and non-radiating networks.
- Avoided an error in MPI parallelization libraries that may have caused a simulation to abort due to a change in network connection.

WinProp 2022.1.3 Release Notes

The most notable extensions and improvements to WinProp are listed by component.

ProMan

Resolved Issues

- Improved the handling of scattered rays at different materials resulting in improvements in accuracy of SBR predictions.
- For the OFDM simplex network planning now the MS results will be considered (if available), so far always the propagation results were considered.
- Resolved an issue with loading a very large topography database.
- Resolved an issue that gave a false error in an urban project solved by IRT method.
- The memory limit shown on the **3D** tab of the **Global Settings** dialog is now displayed correctly. In case of too low value, it should be once manually set to 4 mega pixels.
- Fixed a bug that prevented rays from being displayed in a time-variant case where a transmitter moved along a trajectory.
- Resolved an exception that may have occurred when importing topo data into ProMan.
- An incorrect RunMS error (702) is now avoided for time-variant projects involving fine time increments.

WallMan

Resolved Issues

- Fixed an incorrect interpretation of a topography-database-file extension in capital letters.

newFASANT 2022.1.3 Release Notes

The most notable extensions and improvements to newFASANT are listed by component.

GUI

Resolved Issues

- Avoided an error in MPI parallelization libraries that may have caused a simulation to abort due to a change in network connection.

Release Notes: Altair Feko 2022.1.2

12

Altair Feko 2022.1.2 is available with new features, corrections and improvements. This version (2022.1.2) is a patch release that should be applied to an existing 2022 or 2022.1 installation.

This chapter covers the following:

- [Feko 2022.1.2 Release Notes](#) (p. 114)
- [WinProp 2022.1.2 Release Notes](#) (p. 119)
- [newFASANT 2022.1.2 Release Notes](#) (p. 121)
- [WRAP 2022.1.2 Release Notes](#) (p. 122)

Feko is a powerful and comprehensive 3D simulation package intended for the analysis of a wide range of electromagnetic radiation and scattering problems. Applications include antenna design, antenna placement, microstrip antennas and circuits, dielectric media, scattering analysis, electromagnetic compatibility studies including cable harness modelling and many more.

newFASANT complements Altair's high frequency electromagnetic software tool (Altair Feko) for general 3D EM field calculations, including, among others, special design tools tailored for specific applications like complex radomes including FSS, automated design of reflectarrays and ultra-conformed reflector antennas, analysis of Doppler effects, ultrasound systems including automotive or complex RCS, and antenna placement problems. Advanced solver technologies like the MoM combined with the characteristic basis functions (CBFS), PO/GO/PTD, GTD/PO and MLFMM parallelised through MPI/OpenMP, being some of them especially efficient for the analysis of electrically very large problems.

WinProp is the most complete suite of tools in the domain of wireless propagation and radio network planning. With applications ranging from satellite to terrestrial, from rural via urban to indoor radio links, WinProp's innovative wave propagation models combine accuracy with short computation times.

WRAP is a comprehensive tool for electromagnetic propagation, antenna collocation and spectrum management. WRAP combines propagation analysis, often over large areas with many transmitters and receivers, with system analysis to include complex non-linear equipment properties.

Feko 2022.1.2 Release Notes

The most notable extensions and improvements to Feko are listed by component.

CADFEKO

Features

- Added rendering previews for the copy and translate and copy and rotate operators to show all copies about to be created.
- Added an option to toggle snapping to mesh vertices on the **Modify Snap Settings** dialog.
- Added an option to the project filter to include only parts that are set to use the selected predefined local mesh settings.
- Restored nineteen antennas to the component library that were previously only available in CADFEKO [LEGACY].

Resolved Issues

- Resolved an issue where the wrong number of cable connector pins were written out to .pre file in some cable models, causing the Solver to terminate with `ERROR 23085: Wrong number of continuation lines when specifying cable connector details.`
- Fixed an intermittent bug where the cable bundle dialog would open in a broken state.
- Fixed the geometry export problem which prevented large models from being exported successfully.
- Resolved a problem with the tool for finding distorted mesh elements where only distorted elements found in model meshes were reported and not those present in simulation meshes.
- Fixed an issue converting legacy CADFEKO models where the nets in the schematic would not be correctly connected.
- Changed the `CopyAndMirror` API method to return a single entity rather than a list.
- Fixed an assertion that failed when adding a FEM modal mesh port to an S-parameter configuration.
- Relaxed the validation for converting legacy models to the new CADFEKO format to allow subtract operators that do not subtract any parts. The same validation relaxation is present from the API. In the graphical user interface, geometry to subtract is required when creating subtracted geometry, but the resulting geometry can be modified to contain only the original target for subtraction.
- Parts with faults that are due to extremely small edges will correctly mesh. Before, a bug in the meshing phase could cause an assertion failure upon meshing (or opening a model containing such parts with auto-meshing enabled).
- Resolved a problem where legacy model conversion failed for models containing dielectric media with empty entries in the frequency list table.
- Corrected the FEM line port validation when checking if the wire, which the port is located on, is in a FEM dielectric region. The problem could have caused a solver error if a port was defined on a child part.

- Fixed a bug that could have resulted in crashes when running a script as an application macro, while the same script would work correctly when running it directly from the script editor.
- Resolved an issue where setting the **Suppression of small features** advanced mesh setting to **Ignore** was not affecting the mesh.
- Fixed an assertion that could fail when opening and closing the project filter after having created a new project.
- Resolved a problem where meshing failed on undo after changing the frequency for a model containing a wire port.
- Resolved a problem with the handling of inactive waveguide ports that could lead to the solver terminating with `ERROR 36393: Incomplete specification of a waveguide port on the surface of a dielectric.`
- Reloading a protected model would leave CADFEKO in an unstable state. After the protected model was reloaded, an assert or crash would be triggered when interacting with the 3D view, creating a 3D view or exposing the model.
- Resolved an issue where drop-down lists referencing entities could rarely change to the first created entity of that type instead of the selected option.
- Near fields with a start and end point differing by more than 360 could have resulted in a `Range too big` warning being shown in error.
- Made various improvements to ensure the correct handling of protected models.
- Resolved an issue where model-specific variables could not be evaluated using `EvaluateExpression` from API automation.
- Updated SPICE file browser options to include `*.asc`, `*.txt` and `*.*`.
- Removed lower case, upper case file type repetition from file browsers on various dialogs (browsing for near field data, SPICE circuits or Touchstone files or exporting an image).
- Fixed a crash that could have been triggered when undoing.
- Resolved a crash when attempting to open a Lua script via the API (from another Lua script).
- Resolved an issue where the application would crash when deleting a duplicated model mesh.
- Resolved a crash that could be encountered when adding a schematic view.
- Fixed view anchoring for rotating geometry while on **Model View** display mode.
- Fixed an assert that occurred when wires were unioned inside a PEC region.
- Fixed a problem with the application macro library script for Example Guide (EG) F2 that failed to execute.
- Resolved the issue that the reference impedance could not be set for edge mesh ports on the S-parameter configuration dialog. The solver terminated with an error that no EG card (end of geometry) was found in the `.pre` file when edge mesh ports were used in an S-parameter configuration.
- Resolved an issue where a near field receiving antenna request with multiple faces specified to be combined were incorrectly passed to the solver as individual faces.
- Added CEM verification for near field receiving antenna requests. A model status error is triggered when the request contains Cartesian apertures that cannot be combined or when more than six Cartesian apertures are specified to be combined.

- CADFEKO_BATCH now correctly checks that the directory specified by the FEKO_USER_HOME environment variable (where user settings are stored) exists and if it does not, creates it to avoid a problem later relying on the existence of the directory.
- Improved memory usage for 3D view visualisation.
- The CO card (for coatings) was incorrectly written to .pre file for faces that at some point had a layered dielectric coating applied and were then updated to have the face medium set to layered dielectric. This could lead to a solver error that a triangle cannot be a coated conductor and a thin dielectric sheet at the same time. Layered dielectric face media and coatings are not supported together and the CO card .pre file writing rules have been corrected.
- Added missing API documentation and scripting auto-complete for the `cf.Application.GetInstance()` method.
- Fixed a bug where clicking the OK button more than once while importing sometimes caused an assertion failure.
- Fixed a problem where attempting to open a model by dragging and dropping it into the application could leave CADFEKO in an inconsistent state (with an empty tree) if the model failed to load.
- Resolved the issue that no previews were shown when transforming model meshes.
- Resolved an issue where snapping to zero while creating or modifying a cone could cause an assertion failure.
- Fixed a mapping bug where wires (free edges) and edges (bounding faces) were not mapped correctly to root level wires and edges. This could result in ports that go suspect.
- Corrected cutplanes to affect geometry vertex visualisation.
- Error feedback will now be given when media defined in .inc files fail validation during import.
- Improved the performance for operations involving incremental changes to large collections. This includes a general performance improvement when updating changes for large models.
- Corrected a bug relating to edge ports and the faces defining the edge port. The bug may have caused an error stating that a face is not allowed on a dielectric body.
- Corrected the simplify operation to remove edges between faces if they have local mesh settings that match.
- Resolved a problem that could result in an assert failing while working on the **Constrained Surface** dialog.
- Resolved an assertion failure that could be triggered when dragging an item out of a path sweep in the model tree. An appropriate error message is now shown and the invalid action prevented.
- Multi-selecting a layered dielectric and anisotropic dielectric and editing their properties does not result in an assert anymore. The two types are incompatible and an appropriate error message is displayed.
- Resolved an assertion failure that could be triggered when deleting a line from a union.
- Resolved an issue where the application would crash when undoing changes for voxel meshes.
- Resolved an issue where results would not be generated for protected models without any requests.
- Resolved an issue where the application would crash when replacing one model mesh with a duplicate of that model mesh instance.
- Re-executing a transform tool which fails will no longer crash.

- Changed cable connector path terminal labels back to **Start** and **End**. The labels **StartTerminal** and **EndTerminal** were used in CADFEKO 2022.1 and CADFEKO 2022.1.1.
- Resolved an issue where removing all the ports that an S-parameter configuration depended on did not remove the S-parameter configuration.
- Fixed the problem that locked geometry could be separated.
- Fixed the problem that locked geometry could be exploded or converted to primitive.
- Fixed a bug where the POSTFEKO session file, if it exists, did not get loaded when launching POSTFEKO from CADFEKO.
- Corrected a bug where the repair and sew faces operation could fail an assertion.
- Improved the error message that gets issued when setting a variable to an invalid expression using the **SetExpressions** method.
- Corrected the near field rendering points while editing a near field request.
- Improved far field and near field rendering and made these more consistent.
- Corrected point entry snapping when setting the reference vector of a waveguide port to calculate from the face centre to the point selected.
- Added **Create Port** to the model mesh face context menu.
- Added **Reverse Normals** to the context menu for model mesh curvilinear face.
- The run dialog, shown when running the solver and other non-GUI components, could have repeated output lines.
- Resolved the issue that enabling the named points snap setting did not enable snapping to named points.
- Resolved an issue where pressing F1 on some dialogs did not open the web help.

CADFEKO [LEGACY]

Feature

- Added the **Create Impedance Sheet for Layered Metals** application macro. The application macro creates an effective surface impedance from a stacked metal definition.

POSTFEKO

Resolved Issues

- Fixed assertion failing when opening an older POSTFEKO session file (`.pfs`) containing a 3D view of a model with a FEM modal port.
- Prevented an assertion failure when opening a fek file with a large number of mesh elements.

Solver

Resolved Issues

- Resolved a bug, due an increased usage of MPI tags after a recent upgrade of the Intel MPI runtime, during the factorisation of the ACA matrix.
- Resolved inaccuracies in computing currents through a load of a model solved with the numerical Green's function where the LU decomposition of the static interaction matrix is read from an existing .ngf file.
- Resolved an issue that may have incorrectly resulted in divergence during the MLFMM solution of a configuration included in a simulation containing multiple configurations and media.
- Improved the performance of the matrix fill stage of a simulation of models using VEP with low frequency stabilisation.
- Improved memory-related feedback messages.

Shared Interface Changes

Resolved Issue

- Resolved an issue where launching CADFEKO from POSTFEKO did not open the current model loaded in POSTFEKO.

Support Components

Resolved Issue

- Corrected the Get to Know the New CADFEKO Interface to state that the location of temporary files generated during the import process of geometry and meshes has changed to %FEKO_TMPDIR%. The log files are still located at %FEKO_USER_HOME%.

WinProp 2022.1.2 Release Notes

The most notable extensions and improvements to WinProp are listed by component.

ProMan

Features

- The orientation of the receiving antenna, in point mode, is now displayed on the point and updated as different time-steps are visualised.
- The number of threads used in a simulation is now reported to the log file.

Resolved Issues

- Resolved a regression in the computation of LOS results of indoor projects in point mode.
- Resolved inaccuracies due to duplicated rays from the same walls/wedges in urban IRT predictions. This fix may result in slight changes in computed results.
- Fixed an incorrect behavior in the display of ray paths computed with the Dominant Path Model. The computation of the power and delay time were always correct, just the ray path display could be incorrect.
- Fixed a bug that prevented the display of rays computed via the WinPropCLI RunMS for all but the first time step.
- Aligned header and syntax of trajectory files to display in GUI. The new order for the angles in trajectory files is: Yaw Pitch Roll.
- Resolved an issue related to duplicate rays in CNP projects, with the transmitter inside the CNP building, simulated with IRT with post-processing.
- Fixed a crash that could occur in case a result folder could not be created.
- Resolved a display issue of buildings in 3D view in urban projects with topography.
- The receiving angle, in cases where an interaction point coincides with a receiving pixel, is now correctly computed for ray tracing based propagation models.
- Resolved a visualisation bug, in 3D view, that resulted in buildings being shifted to an incorrect topographical height.

WallMan

Resolved Issues

- Align header and syntax of trajectory files to display in GUI. The new order for the angles in trajectory files is: Yaw Pitch Roll.
- Fixed a case where the speed along a trajectory is not imported/exported as part of the trajectory import/export operation.
- Fixed a crash that might occur when trying to convert a corrupted file. Instead, a proper message will be issued.

AMan

Resolved Issue

- Resolved a bug that resulted in artificially high gains due to violations of interpolation conditions when using antenna patterns from `.msi` files. Interpolation conditions are now strictly enforced.

Application Programming Interface

Features

- Added support for the combination of Urban IRT with Rural Knife Edge Diffraction model to the WinPropCLI.
- Added support for repeaters in the WinProp API.

Resolved Issues

- Fixed a bug that prevented the display of rays computed via the WinPropCLI RunMS for all but the first time step.
- Fixed a crash that could occur in case a result folder could not be created.

newFASANT 2022.1.2 Release Notes

The most notable extensions and improvements to newFASANT are listed by component.

GUI

Resolved Issue

- Resolved an issue with updating surfaces that caused an unexpected Doppler spectrum in the Ultrasound module (US module).

WRAP 2022.1.2 Release Notes

The most notable extensions and improvements to WRAP are listed by component.

General

Features

- Area mode is now the default when the Longley Rice model is used in the Spectrum Viewer.
- Added an Example Guide to the documentation.
- Improved the interaction speed with large databases via the API.
- The required distance between antennas in the Separation Distance Calculator can now be specified up to a one meter resolution. The previous minimum limit was 10 meters.

Resolved Issues

- Starting WRAP from the command line, with user name and password, now uses the saved password. Previously, this resulted in an error.
- Resolved an issue preventing creation, modification and deletion of equipment from API for a user with password.
- Streamlined the modification of a station via the API by taking out an unnecessary step.

Release Notes: Altair Feko 2022.1.1

13

Altair Feko 2022.1.1 is available with new features, corrections and improvements. This version (2022.1.1) is a patch release that should be applied to an existing 2022 or 2022.1 installation.

This chapter covers the following:

- [Feko 2022.1.1 Release Notes](#) (p. 124)
- [WinProp 2022.1.1 Release Notes](#) (p. 129)

Feko is a powerful and comprehensive 3D simulation package intended for the analysis of a wide range of electromagnetic radiation and scattering problems. Applications include antenna design, antenna placement, microstrip antennas and circuits, dielectric media, scattering analysis, electromagnetic compatibility studies including cable harness modelling and many more.

newFASANT complements Altair's high frequency electromagnetic software tool (Altair Feko) for general 3D EM field calculations, including, among others, special design tools tailored for specific applications like complex radomes including FSS, automated design of reflectarrays and ultra-conformed reflector antennas, analysis of Doppler effects, ultrasound systems including automotive or complex RCS, and antenna placement problems. Advanced solver technologies like the MoM combined with the characteristic basis functions (CBFS), PO/GO/PTD, GTD/PO and MLFMM parallelised through MPI/OpenMP, being some of them especially efficient for the analysis of electrically very large problems.

WinProp is the most complete suite of tools in the domain of wireless propagation and radio network planning. With applications ranging from satellite to terrestrial, from rural via urban to indoor radio links, WinProp's innovative wave propagation models combine accuracy with short computation times.

WRAP is a comprehensive tool for electromagnetic propagation, antenna collocation and spectrum management. WRAP combines propagation analysis, often over large areas with many transmitters and receivers, with system analysis to include complex non-linear equipment properties.

Feko 2022.1.1 Release Notes

The most notable extensions and improvements to Feko are listed by component.

CADFEKO

Features

- Added support to define a characterised surface with a thickness as the face medium for faces solved with the MoM/MLFMM.
- Added CEM verification for the pitch length of twisted pair cables.
- Added CEM verification for geometrically thin coatings on mesh elements.
- **Mouse Binding Settings** are now ordered alphabetically and all view interactions can be customised.
- Converted three application macros from the CADFEKO [LEGACY] API to the new CADFEKO API.
- Extended the CADFEKO API by adding the `getApplicationName` method to the `Application` object to return the application's name.
- Extended the CADFEKO API by adding the `getApplicationVersion` method to the `Application` object to return the application's version information.

Resolved Issues

- Resolved a problem that could cause the application to hang when running an external process such as the Feko Solver from the GUI.
- Resolved a problem that could cause CADFEKO_BATCH to crash when called from the GUI.
- Resolved an issue that caused large spaces to be displayed in the output on the **Executing runfeko** dialog.
- Resolved an issue where CADFEKO wrongly passed process priority to RUNFEKO for sequential jobs.
- Made various corrections and improvements to the saving process, in particular, what files are saved when processes are still busy performing calculations.
- When opening `.cfx` files created in CADFEKO [LEGACY] or older versions of CADFEKO, the initial view will be zoomed to the extents of the model.
- Resolved various problems with the view not restoring correctly when re-opening a model.
 - Tiled views are restored correctly when loading a model.
 - The previously selected view is selected when loading a model.
 - The zoom level is restored correctly when loading a model.
- Fixed a crash that could have resulted when closing all windows.
- Fixed a crash that could occur when applying changes on the **Transform View** dialog to a 3D view.
- The **Transform View** button is now correctly disabled on the ribbon for schematic views. Attempting to transform the view with a schematic view active caused the application to crash.
- Fixed a crash on Linux when zooming out in the cable harness schematic view.

- Resolved an issue where opening a model created in CADFEKO [LEGACY] or older versions of CADFEKO could open with a port having unconnected terminals in the schematic circuit.
- Resolved an issue where the dialog that indicates that the application is busy converting a legacy model was hidden behind the splash screen.
- Models with incorrect coaxial cable definitions or incorrect 3D anisotropic medium definitions may have resulted in an error while converting from a legacy model.
- Corrected a problem with number formatting where a decimal separator instead of a space was used as thousands separator.
- CAD fixing with the remove small feature tool, simplify part representation tool or the repair edge tool could have resulted in large faces being removed if the faces were inside solid regions and not touching any of the region boundaries.
- Resolved an assertion failing when removing rows from the **Constrained Surface** dialog.
- Fixed an assertion failure which occurred intermittently when opening the **Create S-parameters** dialog.
- Resolved an assertion failure when duplicating an S-parameter configuration that had no ports defined.
- Introduced more descriptive error messages when regions are unable to mesh.
- Resolved various problems creating FEM volume meshes with symmetry.
- Resolved an issue where cable ports were reported as non-symmetric.
- Fixed a problem where the wrong cable connector names were written to the CI card in the `.pre` file.
- Resolved an issue with cable ports not being imported during `.cfx` import.
- Prevented a crash when pressing Cancel on the **Combine Cables** dialog.
- Fixed model status validation reporting an error for an MTL cable harness where the cable path reference direction was correctly defined.
- Restored twenty three antennas to the component library that were previously only available in CADFEKO [LEGACY].
- Resolved an issue with the align tool being populated incorrectly when adding a component from the **Component Library** to an existing project.
- Creating a union of layered isotropic dielectric faces and anisotropic dielectric regions will no longer trigger an assert.
- Fixed a crash when saving a model with a suspect wire port.
- Resolved a crash when re-opening the project filter in the same session where settings were applied to the project filter while another model was open.
- Resolved an issue where an **Unnamed** error message dialog was shown instead of a pop-up error message when applying an invalid change on any dialog.
- Updated the geometry vertex rendering to only render the vertices and not extra vertices from tessellation.
- Fixed an assertion failure that was triggered when modifying multiple entities at the same time and a tri-state value was invalid or empty.
- Fixed a crash that occurred on Linux when modifying the properties on multiple faces.

- Fixed a crash that occurred on Linux when modifying the numerical Green's function (NGF) settings.
- Fixed a failure when loading models created in CADFEKO [LEGACY] or older versions of CADFEKO containing subtracted geometry parts.
- Fixed mesh refinement rules not being applied when it has a non-default workplane set.
- Mesh overlay display is disabled while tools, other than those where mesh settings can be modified or mesh information is displayed, are open.
- Resolved an issue with **Connectivity** not displaying in the 3D view immediately upon being enabled.
- Resolved an issue with snap points being rendered in the 3D view when no snap points were expected or used.
- Improved the accuracy of windscreen work surface snapping to allow using point entry to create surface lines.
- Resolved an assertion that failed upon geometry modification of a wire referenced by a wire port, where the modification results in the wire becoming an edge.
- Prevented certain actions on child geometry parts through the GUI and API, including converting to primitive, exploding, reversing of normals and unlinking the mesh.
- Added validation to prevent an assertion failing when attempting to path sweep geometry along a disjoint path.
- Added validation to prevent the deletion of a local mesh setting definition that is used in the local mesh settings of a part.
- Resolved an issue where a view with two start pages could have resulted if a model failed to load, with the view being split into two sections. The application had to be restarted to return the view to normal.
- Saving the model is no longer part of the protect and unprotect model feature.
- Protected model validation incorrectly used solution methods on parts that are not root-level parts and could have incorrectly stated that a model cannot be validated.
- Resolved an assertion that failed when meshing a protected model with a larger model unit than the model it was imported into.
- Relaxed optimisation constraint validation so that validation is only done on active constraints.
- Use alphabetical ordering for optimisation collections under the **Construction** tab in the model tree.
- Resolved an issue where the cut of the cutplane was not facing the user by default.
- Corrected the orientation of the Theta and Phi angles when using rotation to define a cutplane.
- Removed unused options from the **Geometry Importer Tool**. ODB++ format can be imported using the **PCB Import Tool**. Gerber format is not currently supported.
- Resolved an issue with incomplete version information being written out to .pre file.
- Resolved a hang when opening a model that was created and saved using a script.
- Resolved an issue with the script editor where the full filename did not get displayed for filenames containing multiple full stops.
- Resolved a crash that could be triggered by clicking on the **Close** button on the application macro dialog while the macro is running.

- Added API support for updating multiple variables simultaneously using the Lua method **SetExpressions**.
- Resolved an issue where some collection methods were missing from the API documentation.
- Resolved an issue where table methods were not showing up in the API documentation.
- Resolved an issue where list methods did not have the correct capitalisation in the API documentation.

EDITFEKO

Feature

- Added support to the SK card to define a thickness for triangles using a characterised surface definition medium. The thickness is used for MoM/MLFMM simulations and is disregarded for RL-GO.

POSTFEKO

Feature

- Added the far field power integral result type to the **Parameter Sweep: Combine Results** application macro.

Resolved Issues

- Resolved a problem on Windows that prevented image exports. An error message stated that the postscript driver was not found.
- Added validation to the **Optimise Model in HyperStudy** macro to avoid executing the Feko solver when the variables in a model did not update correctly.

Solver

Features

- Accelerated the ray tracing phase of faceted UTD simulations of models with a large number of reflection paths or a large number of interactions. The performance gains depend on the geometry of the model and/or the location of the source.
- Upgraded MUMPS to version 5.5.0.
- Improved further both the memory and time requirements when calculating Green's function interpolation tables for specific cases.
- Relaxed an error condition when near field aperture samples are close to zero.
- Added support for characterised surfaces usage with MoM/MLFMM. Models with characterised surfaces are, in general, more computationally efficient to simulate compared to the full model containing all geometrical details.

Resolved Issues

- Print a note that power scaling settings are not effective in characteristic mode analysis.
- A warning about suppressing surface current export is now only issued if the current request includes UTD, faceted UTD or RL-GO triangles.
- Resolved an issue with reporting very high permittivity and permeability values in the `.out` file.

Support Components

Features

- Enabled HyperStudy to work with the new CADFEKO 2022.1.
- Updated the steps for the HyperStudy Example I.3 in the Feko Example Guide to use the model creation script in the macro library.

Resolved Issue

- When launching a parallel simulation across multiple nodes using Intel MPI, the correct number of processes will now be started on each node according to the configuration.

WinProp 2022.1.1 Release Notes

The most notable extensions and improvements to WinProp are listed by component.

ProMan

Features

- Popup windows with information regarding the lack of intersection between walls of a database and the prediction plane are no longer issued when ProMan simulations are launched from the command line.
- ProMan projects can optionally be exported without the database.
- Extended **Postprocessing incl. Tx and Rx** to moving antenna arrays.
- UWB air interface is now supported for urban and rural scenarios.
- Resolved an issue with importing a `.msi` file that has multiple dots in the file name.

Resolved Issues

- Prevented a crash in ProMan in case a trajectory is placed outside the area of the topographical map.
- Improved indoor LOS correction for projects with time-variance, prediction points or planes.
- An explanatory error message will now be issued when a time-variant transmitter moves outside the available topography area.
- Resolved an issue where normalization of channel matrices was not carried out correctly for some cases.
- `.kml` files are now always exported with Longitude/Latitude coordinates for all scenarios.
- Corrected the display of VNLOS and VLOS pixels in some projects (V=Vegetation).

WallMan

Feature

- WallMan now accepts thickness and roughness of a material specified in micrometers.

Resolved Issues

- Fixed a case where only part of a GeoTIFF topography file was converted.
- Outdoor pixels are now computed when an indoor project is computed with IRT.
- Fixed a case where invalid wedges or segments were created for Urban IRT at locations where buildings connect and parallel walls essentially form one wall.

Application Programming Interface

Feature

- Prevented dialog windows related to geometry conversion from appearing when the conversion is performed through the API.

Altair Feko 2022.1 is available with new features, corrections and improvements. It can be applied as an upgrade to an existing 2022 installation, or it can be installed without first installing Altair Feko 2022.

This chapter covers the following:

- [Highlights of the 2022.1 Release](#) (p. 132)
- [Feko 2022.1 Release Notes](#) (p. 136)
- [WinProp 2022.1 Release Notes](#) (p. 139)
- [newFASANT 2022.1 Release Notes](#) (p. 141)
- [WRAP 2022.1 Release Notes](#) (p. 142)

Feko is a powerful and comprehensive 3D simulation package intended for the analysis of a wide range of electromagnetic radiation and scattering problems. Applications include antenna design, antenna placement, microstrip antennas and circuits, dielectric media, scattering analysis, electromagnetic compatibility studies including cable harness modelling and many more.

newFASANT complements Altair's high frequency electromagnetic software tool (Altair Feko) for general 3D EM field calculations, including, among others, special design tools tailored for specific applications like complex radomes including FSS, automated design of reflectarrays and ultra-conformed reflector antennas, analysis of Doppler effects, ultrasound systems including automotive or complex RCS, and antenna placement problems. Advanced solver technologies like the MoM combined with the characteristic basis functions (CBFS), PO/GO/PTD, GTD/PO and MLFMM parallelised through MPI/OpenMP, being some of them especially efficient for the analysis of electrically very large problems.

WinProp is the most complete suite of tools in the domain of wireless propagation and radio network planning. With applications ranging from satellite to terrestrial, from rural via urban to indoor radio links, WinProp's innovative wave propagation models combine accuracy with short computation times.

WRAP is a comprehensive tool for electromagnetic propagation, antenna collocation and spectrum management. WRAP combines propagation analysis, often over large areas with many transmitters and receivers, with system analysis to include complex non-linear equipment properties.

Highlights of the 2022.1 Release

The most notable extensions and improvements to Feko, newFASANT, WinProp and WRAP in the 2022.1 release.

Salient Features in Feko

- CADFEKO 2022.1 has been completely refactored, providing a foundation on which usability and feature improvements can be made. This next-generation interface will also serve as a platform for tighter integration with Altair HyperWorks Products while maintaining a familiar interface for Feko users. View the *Get to Know the New CADFEKO Interface* document for more information.

This refactored version of CADFEKO is included in Feko 2022.1 alongside the legacy CADFEKO. For some older CADFEKO models and Lua scripts as well as specific use-cases and workflows the legacy CADFEKO should be used. The legacy CADFEKO will be removed in a future release, once users have had a chance to give us feedback and have been able to make the transition fully to the new interface.

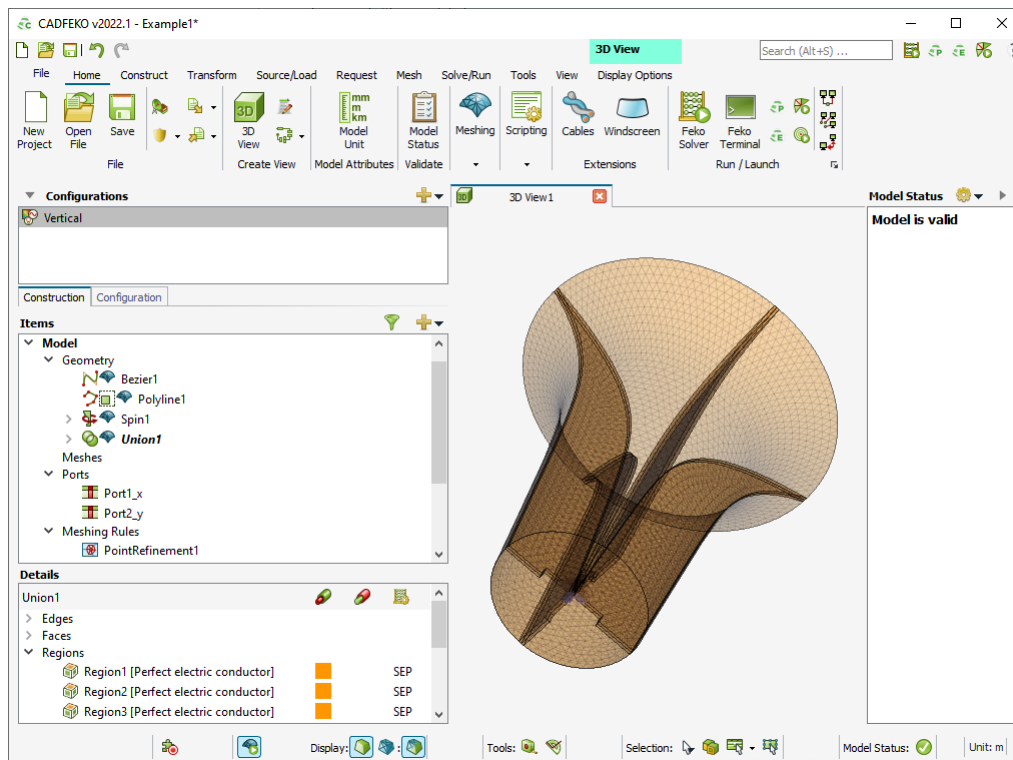

Figure 28: The refactored CADFEKO 2022.1.

- Added support for password-protection of a model. The primary usage of model protection is to allow a prepared simulation model to be shared as a "component" that may be included in the construction of another model, while maintaining limited visibility of the internal details of the model as well as the simulation quantities for anyone who does not know the password for the protected model. When a protected model is imported, no geometry or mesh is visible or editable for that part of the model and limitations are imposed on the requests that may be calculated.

Model protection may also be used to ensure that those who do not have the password are unable to open the model. When using protection in this way, please keep in mind that, though a protected model can be simulated by running the solver, some simulation results may not be calculated and no mesh will be available in POSTFEKO for post processing after simulation. It is generally advisable to unprotect the model before simulation to avoid these limitations.

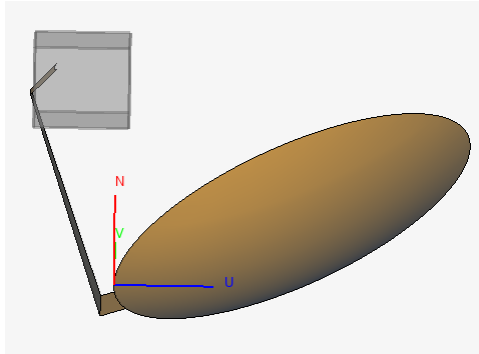

Figure 29: An offset reflector with an imported protected model of a horn (feed) showed in grey in CADFEKO.

Salient Features in newFASANT

- Added support for exporting transmission/reflection coefficients in Feko format.

Salient Features in WinProp

- An array-synthesis tool was added to AMan. Define the array elements in a rectangular array with options such as amplitude tapering for side-lobe suppression and phase difference for beam steering, and generate the radiation pattern. Use the radiation pattern in any ProMan project, for example, for a 5G base station or a radar.

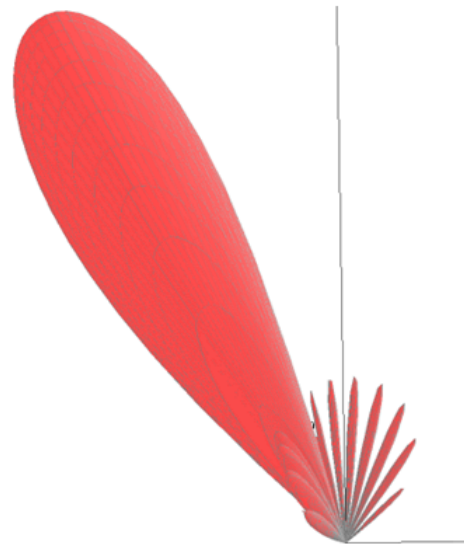
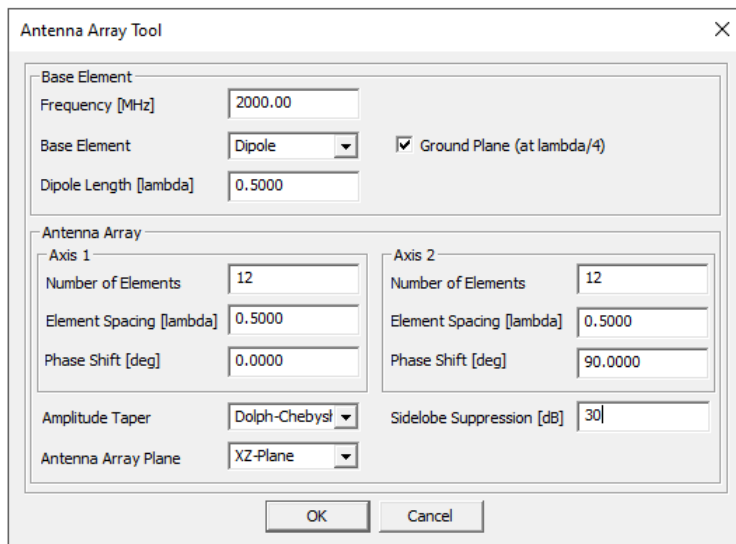

Figure 30: The **Antenna Array Tool** dialog where you can define rectangular array elements.

- The Rural Knife Edge Diffraction prediction model can now be combined with the Urban Intelligent Ray Tracing for accurate predictions among buildings shadowed by topography.

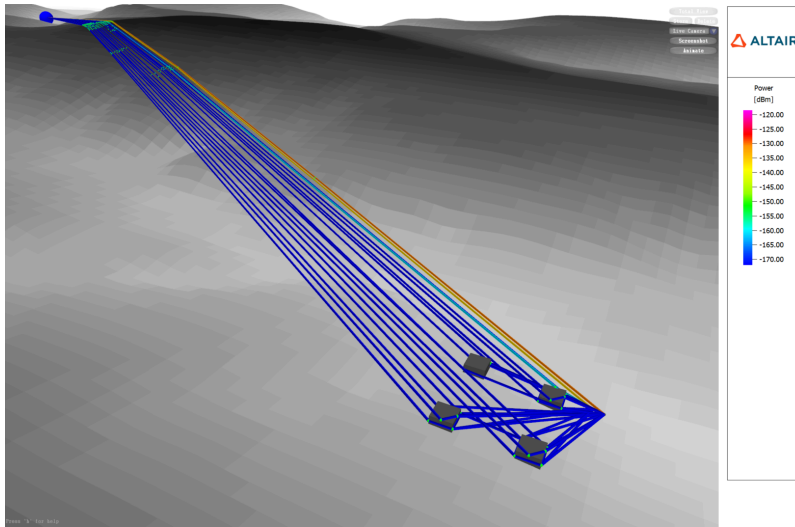

Figure 31: 3D multipath in an urban scenario where the transmitter is shadowed from the buildings due to hilly terrain.

- A library of traffic objects (with an explanation and examples) is now available on [Altair Community](#).

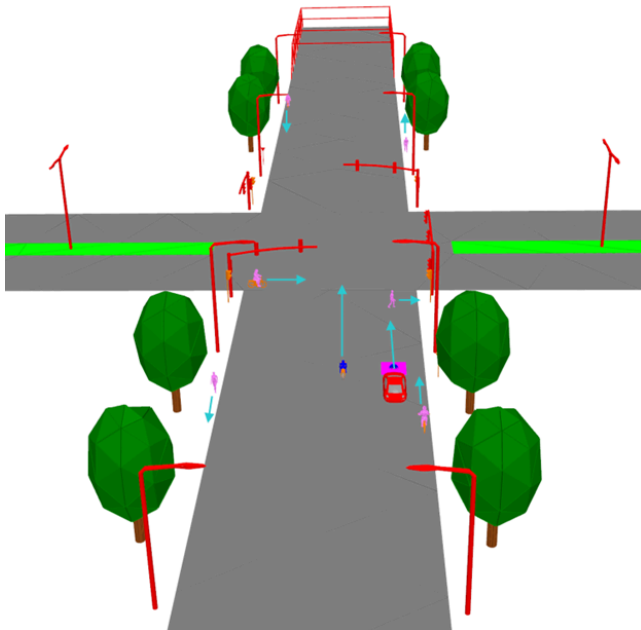

Figure 32: The library contains useful traffic objects that can be used to simulate the performance of automotive radar in traffic.

- Arrays of individual receiving elements (with individual offsets relative to the centre of the array) can now be used in FMCW radar signal post-processing.

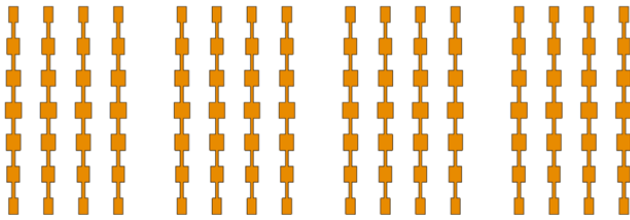

Figure 33: Arrays of individual receiving elements, each with individual offsets relative to the centre of the array.

- The default interaction loss in the Dominant Path Model is now frequency-dependent.

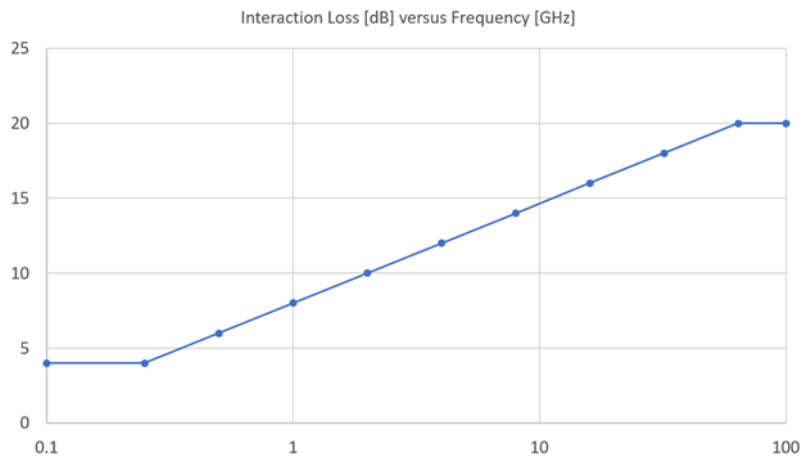

Figure 34: The DPM interaction loss is now frequency-dependent.

Salient Features in WRAP

- WRAP is now available as part of the Altair Student Edition license program.

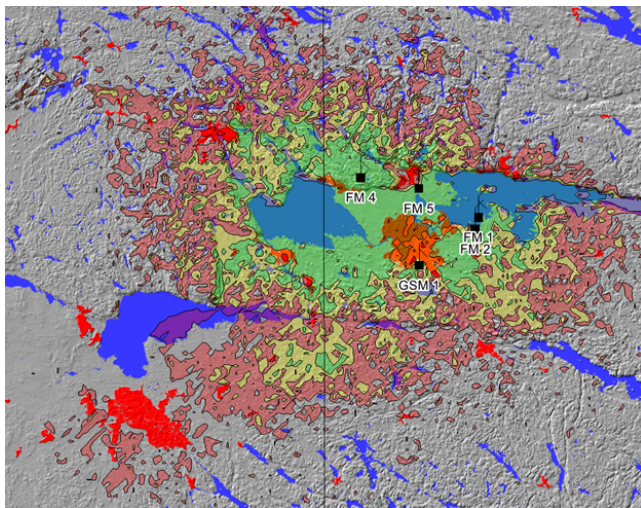

Figure 35: The WRAP student edition is limited to prediction on an area in Sweden.

Feko 2022.1 Release Notes

The most notable extensions and improvements to Feko are listed by component.

CADFEKO

A subset of features and improvements included in the new CADFEKO interface are listed here. View the *Get to Know the New CADFEKO Interface* document for a more extensive list of features and changes in the new CADFEKO. The issues mentioned in this section were reported for older versions of CADFEKO, but are resolved in the new CADFEKO. See the CADFEKO [LEGACY] section for changes to CADFEKO 2022.1 [LEGACY].

Features

- Added support for password-protecting a model and for importing a password-protected model into the current model. **Protection** can be found on the **Home** tab next to **Import** and **Export**.
- Computational electromagnetic validation is now performed continuously. The **Model Status** icon on the status bar indicates the validity of the model. Error and warning messages are displayed in the **Model Status** panel. This new functionality replaces the **CEM validate** tool.
- The new **Separate** tool can be used to disband a union. It returns the individual geometry parts that were combined into a single part by the union.
- Dialogs are dynamically resized to display all contents without scrollbars.
- When adding a new point to a polyline or polygon in CADFEKO, the coordinates from the previous point are used as starting values for the added point.
- Added keyboard shortcuts for a variety of actions including **Include/Exclude**. Additionally, keyboard shortcuts can be customised from the **Keyboard Shortcut Settings** dialog.
- Model extents no longer need to be defined by the user. The model bounding box is automatically calculated.
- Added the option to the **Solver Settings** dialog to select which files to write out when opting to export ray data for RL-GO or UTD.
- It is now possible to apply transforms to cable paths, as well as copy special operations.
- Improved validation to ensure a cable connector has uniquely (case insensitive) named pins, as required by the Feko solver.
- Completed automation for finite antenna arrays.

Resolved Issues

- Added support for specifying the rotation of a coaxial waveguide port. This was possible using the **AW - Waveguide port** card in EDITFEKO, but not directly in CADFEKO due to a regression in a previous release.
- Resolved various issues previously reported against **CEM validate**. The checks are now done continuously and are displayed in the **Model Status** panel.
- Improvements to applying variable changes allowing variables to be updated in some cases that fails in CADFEKO [LEGACY].

- Resolved an issue with excluded ground plane media being defined in the `.pre` file.
- Resolved various import failures due to scale factor limitations.
- Distorted mesh elements created when using larger model extents settings in CADFEKO [LEGACY] no longer occur in CADFEKO.

CADFEKO [LEGACY]

Feature

- Implemented a mechanism to recover backups stored for models converted to the new CADFEKO model format.

EDITFEKO

Features

- Extended the **MB - Specify a modal port** card panel with the options to define analytical FEM waveguide port shapes. Circular and coaxial waveguide ports can now be defined in addition to rectangular waveguide ports.
- Extended the **AB - Modal port excitation** card to support analytical FEM waveguide ports (specified with the **MB** card).
- Extended the **UT - Specify the UTD/RL-GO parameters** card to support the selection of the file or files to which ray data should be written.

POSTFEKO

Feature

- Increased the `.fek` file version to 187 to accommodate new features.

Solver

Features

- Analytical waveguide ports are now supported with the FEM solver. The options regarding these ports can be selected using the MB card in EDITFEKO.
- Added support to export diffracted rays for RL-GO models.
- Added support to export rays to only `.bof` file or only `.ray` file. Previously the export was always to neither or both files.
- Revised the consideration of diffraction effects from curvilinear wedges on planar triangles, resulting in improved accuracy of faceted UTD simulations.

- Updated the memory requirement summary, reported in the `.out` file of an MLFMM solution, to explicitly state that amount of memory required by the preconditioner is not included in the summary.
- Upgraded the CUDA runtime used in GPU computations to version 11.6.
- Improved the robustness of visibility relation considerations in faceted UTD simulations.
- A load can now be defined across the terminals of a network port, when the port is also a geometric port (in other words, a segment, vertex or edge port).
- Reduced the memory footprint of the MLFMM near field matrix when SPAI preconditioner is used on computers with shared memory architecture.
- The time taken to write or read solution coefficients from the `.str` file is now reported in the timing section of the `.out` file.
- Accelerated the ray tracing phase of faceted UTD solutions of models with a high number of interactions.

Resolved Issues

- Resolved a performance regression during monostatic far field computations.
- Reduced both the memory and time required when calculating planar Green's function interpolation tables. This can have a significant impact on resource requirements for some simulations using the planar Green's function.
- Accelerated the ray launching/tracing phase of the RL-GO solution.
- Resolved an issue that led to MPI-related errors, during a parallel MLFMM solution of some models on Windows, due to the number of allocated shared memory buffers exceeding the limits imposed by the operating system per executable. The number of shared memory allocations has been reduced to below ten percent of the maximum limit.
- Resolved an issue that may have led to a deadlock between processes during MLFMM-based near field computations in simulations with a large number of parallel processes on Windows.

Support Components

Features

- Added a selection option to the **Utilities** tab of the Launcher utility to allow selection between CADFEKO and CADFEKO [LEGACY]. When this option is toggled the corresponding CADFEKO version as well as the corresponding documentation relevant to that version will be opened from the Launcher utility.
- When running a simulation using RUNFEKO where CADFEKO_BATCH is used, CADFEKO_BATCH [LEGACY] will be used if the environment has the environment variable FEKO_LEGACY_CADFEKO set to 1.

Resolved Issue

- Resolved a PREFEKO error that occurred when importing an Abaqus file containing ELSET in an element's definition.

WinProp 2022.1 Release Notes

The most notable extensions and improvements to WinProp are listed by component.

General

Resolved Issue

- Resolved a crash that occasionally may have occurred when running CoMan.

ProMan

Features

- A library of traffic objects has been created for automotive-radar simulations. This library, with explanation and examples, is available from the Altair Knowledge Base.
- Added support for multi-threaded indoor IRT predictions from a single transmitter. Parallelization was previously only supported across sites or transmitters such that all computations per transmitter was done using only one thread.
- The default interaction loss in the dominant path model is now frequency dependent.
- Rural knife edge diffraction can now be combined with urban intelligent ray-tracing to obtain accurate multipath predictions among buildings that are shadowed by topography.
- Previously, only direct rays ending in a CNP building were considered for predictions within the building. This has now been improved to include rays with additional interactions such as transmission and reflection, resulting in improved accuracy.
- Added support for the use of arrays of individual receiving elements, with individual offsets relative to the centre of the array, in FMCW radar signal post-processing.
- Added support to show all time steps of Doppler-Range heat plots in a single figure. Moreover, IQ data can be created for all time steps.
- Added the option to display prediction-point results for all time steps at once in time variant simulations.
- Modified the syntax of the exported IQ channel data so that the exported file can easily be imported in third-party software such as numerical computation tools or spreadsheet applications.

Resolved Issues

- Fixed a bug due to which the gain of a transparent repeater could not be defined in a propagation-only project, after which a crash could occur during the simulation.
- Corrected the superposition of the different polarisations to the total contribution for the results which include the MS antenna.
- Topography information is now correctly considered in the vertical plane for urban scenario predictions using COST/KE/P.1411 models in projects where the transmitter is located outside the prediction area.

- Increased the precision, with which element offsets of a receiving array are reported in the output ASCII files, from two to six decimal places.
- Corrected the transmitter height when absolute height to the sea level used in some rural and indoor models.

WallMan

Resolved Issue

- Resolved an issue with the pre-processing of a CNP model giving unintended error messages.

AMan

Feature

- AMan is enhanced with an array-synthesis tool, which is useful in 5G applications. Starting with any antenna element pattern it will produce the array pattern of a rectangular array. Options include phase difference for beam steering and amplitude tapering for side-lobe suppression.

Application Programming Interface

Feature

- Added signal handling and exit process clean-up when WinPropCLI simulations are halted, for instance, by pressing CTRL+C.

newFASANT 2022.1 Release Notes

The most notable extensions and improvements to newFASANT are listed by component.

GUI

Feature

- Added support for exporting transmission/reflection coefficients in Feko `.tr` file format.

Solver

Resolved Issues

- Made various improvements to the CBFM when applied to non-RCS simulations to resolve issues noted in the Feko 2022 release of this capability.
- Materials defined by reflection/transmission coefficients are now correctly considered in the MONCROS module.

WRAP 2022.1 Release Notes

The most notable extensions and improvements to WRAP are listed by component.

General

Features

- A Student Edition of WRAP is now available. While it has restrictions related to the geographical area and the number of stations, almost all features of the commercial version are available.
- Updated atmospheric attenuation calculations to ITU-R P.676-12.

Resolved Issues

- Corrected the calculation of atmospheric attenuation between 57 and 63 GHz in several models.
- Added a check to prevent changing the class of a linked station in multiple edit mode. The obtained behaviour is in line with what is expected for single edit mode.

WRAP MapDataManager

Features

- Added support for tiling vector data from OpenStreetMap in Shapefile format. This enables easy and quick access to vector data in the map viewer.
- Ensured that simulation results, when displayed, will always appear on top of any other layers that may exist in the map.

Altair Feko 2022.0.2 is available with new features, corrections and improvements. This version (2022.0.2) is a patch release that should be applied to an existing 2022 installation.

This chapter covers the following:

- [Feko 2022.0.2 Release Notes](#) (p. 144)
- [WinProp 2022.0.2 Release Notes](#) (p. 146)
- [newFASANT 2022.0.2 Release Notes](#) (p. 148)
- [WRAP 2022.0.2 Release Notes](#) (p. 149)

Feko is a powerful and comprehensive 3D simulation package intended for the analysis of a wide range of electromagnetic radiation and scattering problems. Applications include antenna design, antenna placement, microstrip antennas and circuits, dielectric media, scattering analysis, electromagnetic compatibility studies including cable harness modelling and many more.

WinProp is the most complete suite of tools in the domain of wireless propagation and radio network planning. With applications ranging from satellite to terrestrial, from rural via urban to indoor radio links, WinProp's innovative wave propagation models combine accuracy with short computation times.

newFASANT complements Altair's high frequency electromagnetic software tool (Altair Feko) for general 3D EM field calculations, including, among others, special design tools tailored for specific applications like complex radomes including FSS, automated design of reflectarrays and ultra-conformed reflector antennas, analysis of Doppler effects, ultrasound systems including automotive or complex RCS, and antenna placement problems. Advanced solver technologies like the MoM combined with the characteristic basis functions (CBFS), PO/GO/PTD, GTD/PO and MLFMM parallelised through MPI/OpenMP, being some of them especially efficient for the analysis of electrically very large problems.

WRAP is a comprehensive tool for electromagnetic propagation, antenna collocation and spectrum management. WRAP combines propagation analysis, often over large areas with many transmitters and receivers, with system analysis to include complex non-linear equipment properties.

Feko 2022.0.2 Release Notes

The most notable extensions and improvements to Feko are listed by component.

CADFEKO

Resolved Issues

- Resolved an issue with the handling of cable loads in models with multiple configurations. Additional (unrequested) load results could sometimes be available in POSTFEKO due to loads not being cleared correctly between configurations.
- Avoid creating zero volume tetrahedral mesh elements in models with symmetry.

POSTFEKO

Resolved Issues

- Resolved several issues with the handling of filenames containing multiple full stops (periods).
 - POSTFEKO session files containing multiple full stops can now be saved through the API.
 - Error and warning messages are corrected to reference the complete filename.
 - The specified filename is now used in full when exporting currents or near field results.

Solver

Feature

- Significantly improve memory usage when activating ray export for the RL-GO.

Resolved Issues

- When interrupting a simulation on Windows by pressing Ctrl+C, orphan solver processes will no longer remain and licenses will be released correctly.
- Resolved the problem that licenses were not checked back in upon cancellation of a parallel Feko run, resulting in an incorrect accumulation of checked out units in subsequent runs. This was caused by a regression in Feko 2022.
- An error resulting in higher memory usage than expected for MLFMM has been resolved.
- Resolved an error in a model with cable harnesses having multiple configurations.
- An informative error message is now issued for cases where the orientation of cable segments, relative to nearby geometry, may be problematic during the solution.
- The processing of receiving antennas in wideband simulations using asymptotic solvers has been optimized. This will result in faster overall simulation times.
- Resolved an internal error during geometry processing of a VEP model with metallic faces.

Shared Interface Changes

Features

- Added the **Create Frequency Ranges** macro to create sub-models in a directory for each frequency range specified. A specific solver (MoM, MLFMM, ACA) can be assigned to each frequency range to optimise run time. Use the **Combine Results** macro in POSTFEKO to merge the results across the different frequency ranges.
- Updated the **Optimise model in HyperStudy** macro to automatically create a HyperStudy session with the Feko model, solver, variables and output data sources set up in the session.

Support Components

Resolved Issue

- Removed the incorrect unit displayed for the XPR axis for the **MIMO Performance Evaluation** application macro.

WinProp 2022.0.2 Release Notes

The most notable extensions and improvements to WinProp are listed by component.

ProMan

Features

- Improved the behavior of the window scroll when deleting a site or antenna in a long list. Now the window cursor stays where the deleted site or antenna was, instead of scrolling to the top of the list.
- Added support for time-variant predictions, in point mode, in a static indoor database.
- Added a new transmitter type, the repeater. This enables simulation of an important class of communication scenarios in which a signal reaches its destination via single or multiple “hops”.
- The consideration of propagation phenomena, such as reflection, diffraction, transmission and scattering, of different materials in a database can now be set or modified in ProMan. In previous releases, such changes were only possible in WallMan.

Resolved Issues

- Improved the robustness of duplicate ray detection during IRT predictions.
- Resolved a bug that resulted in a crash when simulating a time-variant project with multiple prediction heights using IRT.
- Fixed a bug that prevented the use of the parabolic equation solver.
- Resolved potential inaccuracies in point mode results due to numerical precision issues.
- The combination of time-variant simulation and trajectory mode is no longer allowed, unless all dynamics along the trajectory are zero.

WallMan

Feature

- Improved `.gml` database conversion to the WinProp indoor and outdoor binary formats.

AMan

Resolved Issue

- Increased the number of input files that can be converted to beam and envelope patterns to more than 500.

Application Programming Interface

Feature

- Site ID related network planning results, such as cell area and number of receiving sites, can now be computed with the WinProp API.

Resolved Issue

- Resolved a bug that resulted in a crash during OFDM network planning predictions of a project, with prediction planes, simulated with the API. Additionally corrected the used transmitter power, in the API, for a project with a transmitter set to non-EIRP mode.

newFASANT 2022.0.2 Release Notes

The most notable extensions and improvements to newFASANT are listed by component.

Solver

Resolved Issue

- Resolved a slowdown with the hybrid MPI/OpenMP simulations when using the MoM module.

WRAP 2022.0.2 Release Notes

The most notable extensions and improvements to WRAP are listed by component.

General

Features

- Provided more guidance with messages when a user opens a project with a GeoClass that differs from the GeoClass of other open projects.
- Added a collocation interference diagram that shows at a glance the level of interference, if any, between all pairs of transmitters and receivers.
- Added support of exporting line results in `.kml` or `.kmz` file formats.
- Implemented a frequency sweep capability, with proper graphical results presentation, in the **Collocation-Interference** tool.

Resolved Issues

- Fixed a crash that could occur when creating and working with a radio net without having defined **valid from** and **valid to**.
- Fixed a bug due to which ITU-R P.526 did not respect the user-defined values for temperature and water vapour density in the calculation of atmospheric attenuation.
- Fixed a bug in the temperature dependence of atmospheric attenuation. Atmospheric attenuation now decreases with increasing temperature in accordance with ITU-R P.676-2.
- Fixed inaccurate coverage results that could occur when using ITU-R P.2001 over both land and sea in the same simulation.
- Resolved a crash that could occur when a group is dragged and dropped from the project view into the map view.
- Avoided rare cases where the Coverage calculator might not release the license when done.
- Corrected the searching algorithm for stations close to national borders.
- Added the missing option **This Project** in the selection of a station template in the **Cost and Coverage Optimizer**.
- Improved the robustness of WRAP by reducing the number of compiler warnings in multiple places.

Altair Feko 2022.0.1 is available with new features, corrections and improvements. This version (2022.0.1) is a patch release that should be applied to an existing 2022 installation.

This chapter covers the following:

- [Feko 2022.0.1 Release Notes](#) (p. 151)
- [WinProp 2022.0.1 Release Notes](#) (p. 154)
- [newFASANT 2022.0.1 Release Notes](#) (p. 156)

Feko is a powerful and comprehensive 3D simulation package intended for the analysis of a wide range of electromagnetic radiation and scattering problems. Applications include antenna design, antenna placement, microstrip antennas and circuits, dielectric media, scattering analysis, electromagnetic compatibility studies including cable harness modelling and many more.

WinProp is the most complete suite of tools in the domain of wireless propagation and radio network planning. With applications ranging from satellite to terrestrial, from rural via urban to indoor radio links, WinProp's innovative wave propagation models combine accuracy with short computation times.

newFASANT complements Altair's high frequency electromagnetic software tool (Altair Feko) for general 3D EM field calculations, including, among others, special design tools tailored for specific applications like complex radomes including FSS, automated design of reflectarrays and ultra-conformed reflector antennas, analysis of Doppler effects, ultrasound systems including automotive or complex RCS, and antenna placement problems. Advanced solver technologies like the MoM combined with the characteristic basis functions (CBFS), PO/GO/PTD, GTD/PO and MLFMM parallelised through MPI/OpenMP, being some of them especially efficient for the analysis of electrically very large problems.

WRAP is a comprehensive tool for electromagnetic propagation, antenna collocation and spectrum management. WRAP combines propagation analysis, often over large areas with many transmitters and receivers, with system analysis to include complex non-linear equipment properties.

Feko 2022.0.1 Release Notes

The most notable extensions and improvements to Feko are listed by component.

CADFEKO

Resolved Issues

- Made improvements to volume meshing performance after changes introduced in Feko 2021.2.2 may have caused volume meshing to be slower.
- Resolved an issue with CEM validate incorrectly reporting an error for models containing SEP regions and finite arrays to be solved with the domain Green's function method (DGFM). This combination is supported.
- Resolved an issue with the visualisation of connector pins in the cable harness schematic view in Feko 2022.
- Resolved an issue that may have prevented reading solutions from an existing `.str` file for models containing circular waveguide ports. This could have caused unintended re-calculation of solutions rather than using existing solutions. For models that suffered from this behaviour, the `.str` will need to be created once using this version of Feko. The behaviour in subsequent simulations should be as expected. This change will affect the precision of values used in waveguide port point definitions generally.
- Resolved an issue where the properties of a cable shield could not be set through the API if the cable shield previously referenced a medium that no longer exists in the model.
- Resolved an issue where the outer radius of a cable bundle was required to be much larger than the minimum **Total shield radius** value displayed on the **Advanced** tab of the **Cable shield** dialog of the cable shield applied to the bundle.
- Resolved an issue with the number of frequency points written out by the **Parameter Sweep: Create Models** application macro. This could have triggered a `Number of frequency points mismatch` error when using the **Parameter Sweep: Combine Results** application macro in POSTFEKO.
- Resolved the issue that only complex impedance loads could be added to transmission line ports. All load types, for example series or parallel circuits, can now be applied to transmission line ports.
- Resolved an assertion failing with the message `Assertion failed: getLayer()` when working with network schematics. After deleting network schematic elements in a certain order, the assertion failure could be encountered in various ways, including further modifications to the model, re-opening the model after saving it, or when importing another `.cfx` model.

POSTFEKO

Resolved Issue

- Resolved an issue with Cartesian graphs where the graph axes were not updated correctly when the axis unit changed due to changes made to the graph. Showing or hiding a trace with a different

range from the plotted traces may have seemed to cause traces to disappear from the graph until zooming to extents or re-applying the **Axis settings**.

Solver

Feature

- Improved the robustness of creeping ray path computations near transition regions of faceted UTD models.

Resolved Issues

- Improved the accuracy of receiver power calculations in coupled MoM/RL-GO or MoM/faceted UTD simulations.
- Improved the efficiency of the Huygens source processing phase of an RL-GO solution, resulting a speed-up of up to 35% for in some cases.
- Corrected an error that may have resulted in inaccurate calculation of power when using the receiving antennas with faceted UTD solver.
- Resolved an issue that may have resulted in unexpected termination of the solution or inaccurate results when using the ACA solver with plane wave source/s looped over multiple directions.
- Resolved an internal error that occurred during the calculation of interpolation tables of a model with a planar multi-layer substrate and wire ports.
- Resolved an issue where results for angles of incidence in a loop of multiple plane waves that were already completed may not have correctly been loaded and shown in POSTFEKO if the user terminates the simulation.
- Optimize the calculation phase of the spherical mode receive antenna.
- Cable analysis problems solved using the MTL method using will not incorrectly trigger error 55007. This resolves an error introduced in Feko 2022.
- Resolved a regression in Feko 2022 that resulted in longer runtimes than expected when re-using solution coefficients from a `.str` file with the MLFMM solver.
- Resolved an issue that may have caused rapid non-physical variations in the reflection coefficient phase when solving some periodic structures using periodic boundary conditions.
- Resolved an issue that resulted in multiple `.ffe` files, each containing a single direction, being written out for monostatic RCS requests in a recent release. A single `.ffe` file containing results from all directions is now written to disk.
- The test to determine when grating lobes may impact on results for simulations using oblique PBC unit cells has been refined so that a warning about potential inaccuracies is only given when relevant.
- An MPI error that occurred in some combinations of parallel processes stating that `message sizes do not match across processes` is now avoided.

Shared Interface Changes

Resolved Issue

- Resolved an issue where In-App Licensing was used instead of HPC Licensing when the Solver was started from a Feko Terminal opened from within a Feko graphical user interface (GUI) application. HPC Licensing should apply where a solver is not started from inside a graphical user interface application and a SolverHPC license feature is present. Feko Terminals opened from the Launcher utility was not affected by this issue.

Support Components

Feature

- The automatic mesh refinement script has been extended to cater for simulation models that include referenced files.

Resolved Issues

- Resolved an issue where opening the Feko help from the Launcher utility invoked two instances of the help in the web browser.
- Resolved an issue that may have caused a memory violation when a large number (> 500) samples were required in ADAPTFEKO.
- Added consistency checks and a more verbose error message when importing near field files as equivalent sources or receiving antennas.
- Resolved the issue that the Feko help could not be opened from the Launcher utility in server installations.

WinProp 2022.0.1 Release Notes

The most notable extensions and improvements to WinProp are listed by component.

ProMan

Feature

- Extended MIMO network planning from 4 to 8 streams.

Resolved Issues

- Fixed an incorrect reading of the phase information from antenna patterns given in `.ffe` files.
- Network planning results are now displayed for all time steps in a project with a moving transmitter.
- Rays can now be displayed in all relevant layers of CNP projects.
- Disabled condition number computations, during mobile station post-processing, of a SISO project.
- Resolved a regression introduced in a previous version that resulted in the incorrect computation of the transmission matrix entries of the horizontal polarization.
- Accelerated the 2D display of large urban projects.
- For a prediction point that moves with an object in a time-variant simulation, the rotation of the mobile antenna pattern with the object, if any, will now also be considered during RunMS.
- Resolved a crash that could occur during RunMS computation with Doppler Spread requested.
- Improved the handling of diffraction considerations around walls near sub-divisions, resulting in enhanced accuracy of SBR calculations.
- Resolved a crash that may occur during network planning, with EMC analysis, in a project without an associated `.emc` file.
- Resolved an issue that resulted in non-existent lines being displayed in 2D view in ProMan for some large databases.
- Disabled data export along a polyline for trajectory and point-mode results.
- Result-plot legends defined on processed results, such as after an arithmetic operation, are discarded when unprocessed data are displayed afterward, to avoid using a scale that is not appropriate. This was previously not the case.
- Negative prediction heights with respect to sea level can now be specified in case topography includes such low-lying land.

WallMan

Resolved Issues

- It is now possible to split various formats of large topographical maps into tiles upon conversion into the WinProp binary format. The converted tiles can then be more efficiently loaded and viewed in ProMan via the generated `.tdi` index file.

- Improved the detection of whether the user specified an incorrect coordinate system for topography and clutter map conversions.
- Resolved an issue that resulted an incorrect clutter shape when defining clutter, based on a polygon, in an urban database.
- Resolved an issue related to the orientation of topographical maps, after conversion from the digital terrain elevation format into the WinProp binary format.
- Resolved an issue that resulted an incorrect clutter shape when defining clutter, based on a polygon, in an urban database.

Application Programming Interface

Features

- Enabled Doppler shift results and PropSim channel output for projects with trajectories simulated with WinPropCLI.
- Added support for Components to the API.

Resolved Issues

- Resolved a bug that resulted in "NaN" being written out for some points in ASCII result files of some trajectory-mode projects.
- Resolved an issue that leads to different RunMS results between WinPropCLI and ProMan when the maximum number of rays is much higher than the default value.
- Resolved an infinite loop condition that may occur during predictions with the SRT using the API on Linux.

newFASANT 2022.0.1 Release Notes

The most notable extensions and improvements to newFASANT are listed by component.

General

Resolved Issues

- Various improvements to have been made to the CBFM when applied to non-RCS simulations to resolve issues noted in the Feko 2022 release of this capability.

GUI

Resolved Issues

- Fixed an error that resulted in the incorrect orientation of the multipole antenna in the GTD module for some cases.
- Rendering errors with ray tracing visualisation option in the US (Ultra Sound) module have been fixed.
- An error which caused an error in the Java runtime environment when closing the application on some Linux systems has been resolved.
- Corrected a backwards compatibility problem that may have occurred when opening old models with imported field sources. Various changes were also made in order to improve visualisation performance.

Solver

Features

- A new material definition method, based on reflection and transmission coefficients has been added for the MoM module. This material definition method can be used to get more accurate results when modelling radomes that include FSS structures, after characterising the FSS unit-cell using the periodic structure module.
- Added support for multiple active sources when the coupling is requested in the US module.

Resolved Issue

- Improved the meshing speed on Windows operating systems.

Altair Feko 2022 is available with new features, corrections and improvements. Altair Feko 2022 is a major release. It can be installed alongside other instances of Altair Feko.

This chapter covers the following:

- [Highlights of the 2022 Release](#) (p. 158)
- [Feko 2022 Release Notes](#) (p. 161)
- [WinProp 2022 Release Notes](#) (p. 164)
- [newFASANT 2022 Release Notes](#) (p. 167)
- [WRAP 2022 Release Notes](#) (p. 168)

Feko is a powerful and comprehensive 3D simulation package intended for the analysis of a wide range of electromagnetic radiation and scattering problems. Applications include antenna design, antenna placement, microstrip antennas and circuits, dielectric media, scattering analysis, electromagnetic compatibility studies including cable harness modelling and many more.

WinProp is the most complete suite of tools in the domain of wireless propagation and radio network planning. With applications ranging from satellite to terrestrial, from rural via urban to indoor radio links, WinProp's innovative wave propagation models combine accuracy with short computation times.

newFASANT complements Altair's high frequency electromagnetic software tool (Altair Feko) for general 3D EM field calculations, including, among others, special design tools tailored for specific applications like complex radomes including FSS, automated design of reflectarrays and ultra-conformed reflector antennas, analysis of Doppler effects, ultrasound systems including automotive or complex RCS, and antenna placement problems. Advanced solver technologies like the MoM combined with the characteristic basis functions (CBFS), PO/GO/PTD, GTD/PO and MLFMM parallelised through MPI/OpenMP, being some of them especially efficient for the analysis of electrically very large problems.

WRAP is a comprehensive tool for electromagnetic propagation, antenna collocation and spectrum management. WRAP combines propagation analysis, often over large areas with many transmitters and receivers, with system analysis to include complex non-linear equipment properties.

Highlights of the 2022 Release

The most notable extensions and improvements to Feko, WinProp and newFASANT in the 2022 release.

Salient Features in Feko

- The flexibility of Feko solvers has been extended to support hybrid simulations where faceted UTD is used to solve some parts of the model and other parts are solved with the MoM. Both fully coupled and uncoupled simulations are supported, though dielectrics in the MoM region are not yet supported. Receiving antennas (defined using far field, near field or spherical modes) may also be included in the simulation. Additional optical effects as well as higher-order effects are added to the faceted UTD enabling more accurate simulations for many cases.

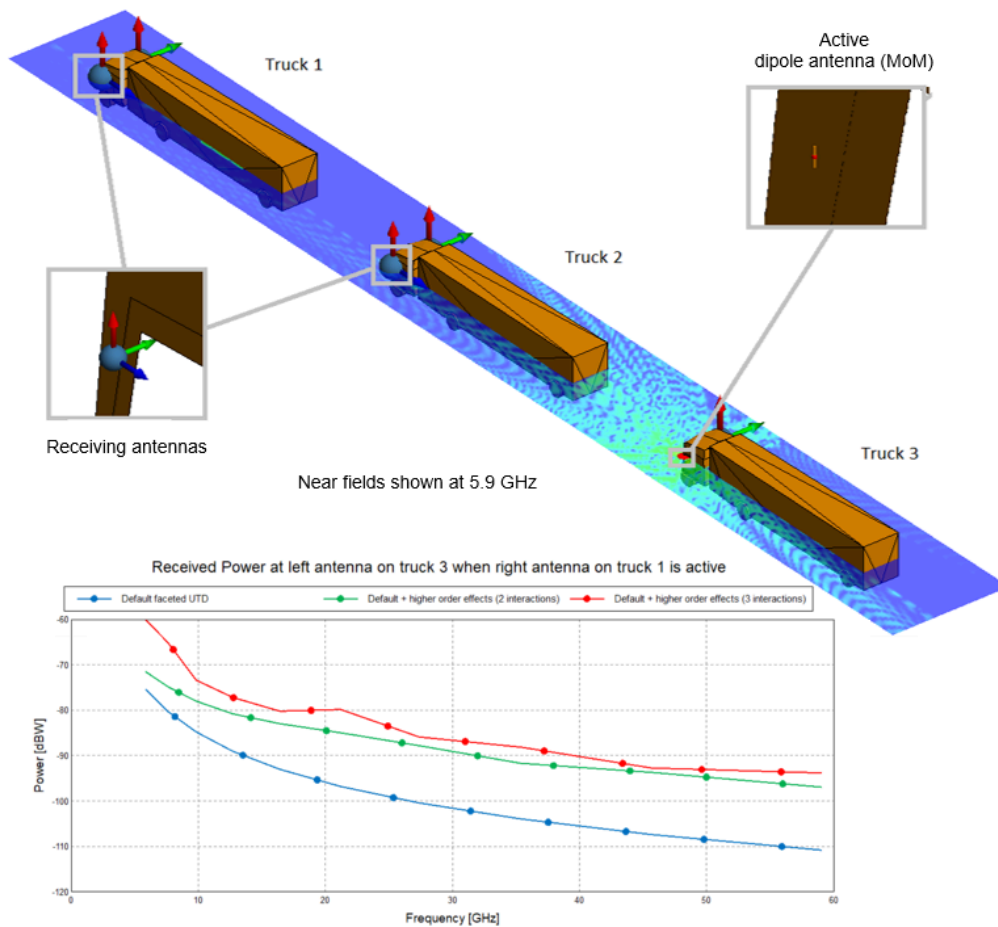
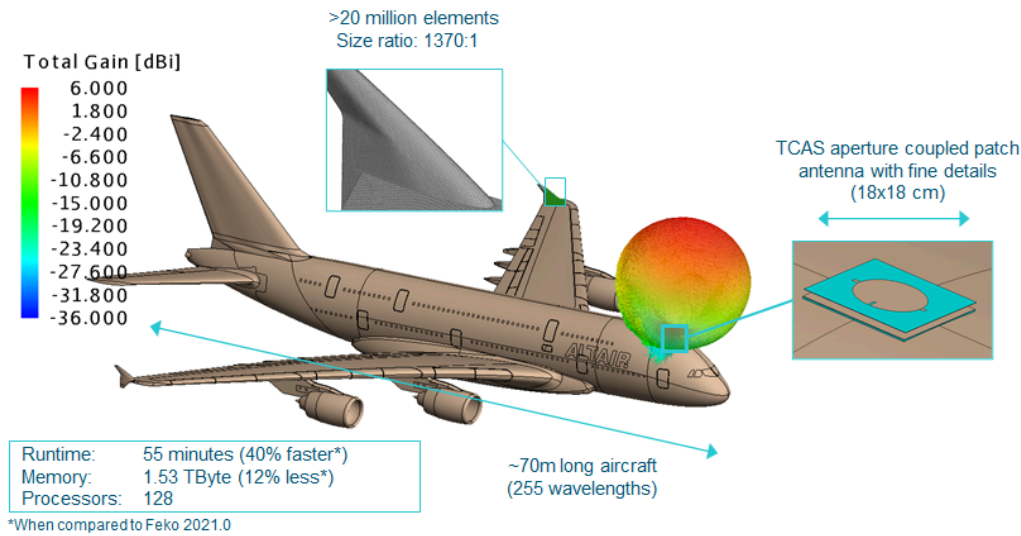

Figure 36: Faceted UTD coupled with MoM used to analyse the field distributions and antenna coupling for rear-view mirror mounted communication antennas in a set of platooning trucks at different frequencies. Multiple interactions and the inclusion of higher-order effects result in more accurate calculation of coupling between certain combinations of antennas.

- Improvements in the application of shared memory and low-level MPI optimisations in the MLFMM solution result in improved parallel efficiency (both runtime and memory) for highly distributed simulations (across multiple nodes).



Salient Features in WinProp

- The calculation of Doppler shift due to movement or rotation of objects around any 3D axis has been added.

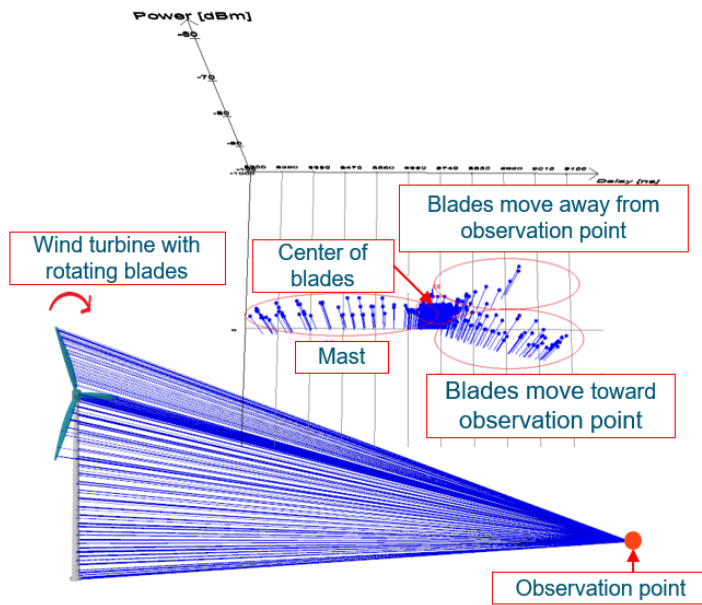

Figure 38: Calculation of Doppler shift due to the rotation of the blades of a wind turbine.

- Higher accuracy of solutions using the SBR (Shooting Bouncing Rays) solver is achieved by using a hybrid ray tracing approach which employs path verification from standard ray tracing.
- When viewing radio-coverage results in a 3D view, transmitter antenna patterns can be displayed - allowing for easier visual verification and interpretation of the results.
- The API has been extended to support the generation of 5G beam patterns as well as automation of FM-CW post processing.

Salient Features in newFASANT

- A new workflow has been added to get accurate and fast simulation results for even more complex and realistic multi layer radomes with frequency selective surface (FSS) structures in newFASANT. The radome and FSS is first characterised in terms of reflection/transmission and is then applied as a material to the relevant surface when configuring the full radome analysis.

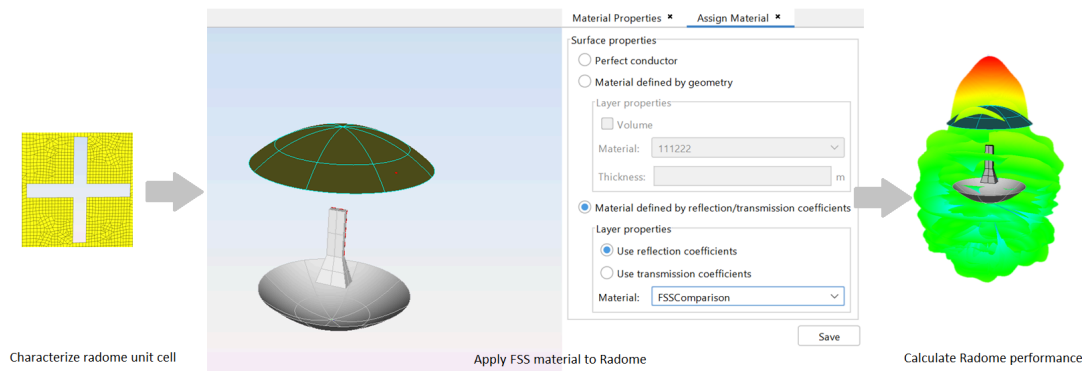

Figure 39: The new workflow for accurate and fast characterisation of multi layer radomes with FSS performance based on pre-characterisation of the radome and FSS as a material.

- The MoM module now supports the usage of the Characteristic Basis Function Method (CBFM) for non-RCS calculations.
- Near fields calculated using Feko solvers on a Cartesian boundary in *.efe/*.hfe format may now be imported as a simulation source.

Feko 2022 Release Notes

The most notable extensions and improvements to Feko are listed by component.

CADFEKO

Features

- Extended near field data with the option to allow using all data blocks in the specified file(s).
- Made changes to the **Solver settings** dialog to support the latest faceted UTD solver extensions.
- Upgraded the meshing library to the latest version. Improvements include more robust meshing of cable cross sections.

Resolved Issue

- Resolved an issue with advanced solver settings not being applied correctly. Using the direct sparse solver could result in a warning being issued erroneously when running the solver.

EDITFEKO

Feature

- Enabled the **UT - Specify the UTD/RL-GO parameters** card **Corner and tip diffraction**, **Higher-order effects** and **Uncoupled with moment method** checkboxes for **Faceted UTD**.

Solver

Features

- Added support for hybridised coupled and uncoupled MoM/Faceted UTD simulations.
- Added support for the receiving antenna with the faceted UTD solution.
- Added support for computing corner diffraction to the faceted UTD solver.
- Added support for multiple reflections plus one diffraction as a higher-order effect for faceted UTD.
- The version of the MPI runtime is printed now to the `.out` file as well as the screen for information.
- Upgraded to the latest Microsoft MPI version.
- Upgraded to Intel MPI 2021 update 2.
- Upgraded MPICH to version 4.0.1.
- Improved memory scaling relative to the number of parallel processes used in a FEM or FEM/MoM simulation.
- The MLFMM fast near field computation is computed in chunks where memory resources are insufficient.
- Improved the efficiency of FEM based iterative solution.

- RL-GO now supports edge diffraction with receiving antennas and fast far fields.
- Improved the parsing of `.rei` XML files from PollEx to allow for a more compressed format where trace/via currents may be suppressed for some frequencies.
- Improved the near and far field computation times for physical optics (PO) models.
- Reduced the memory footprint of parallel simulations.
- Reduced the memory footprint of the field calculation phase of parallel MLFMM solutions.
- Improved the modal and waveguide port mode data in the `.out` file to report a table of the received complex mode power values for passive modes instead of the backward wave mode expansion coefficients.
- `Warning 3423` is now issued only once in standard output. Details of the affected elements are reported to the `.out` file.

Resolved Issues

- Improved the robustness of the faceted UTD solver with respect to corner diffraction.
- Improved the accuracy of the faceted UTD solver with respect to wedge and corner diffraction.
- Improved the accuracy of faceted UTD simulations of some models where diffracted ray effects are considered.
- Resolved an issue that led to a fatal MPI error during the matrix fill phase of a MoM solution of a model solved using Microsoft MPI as the parallelisation library. Note that Microsoft MPI Version 10.1.12498.18 or newer may be required.
- In order to accommodate changes in MPI behaviour, the return code from the Feko solver has been revised. A return code of 0 indicates that the Feko solver terminated successfully, with the possibility of notes and warnings. A return code of 2 indicates that the Feko solver encountered an error. Previously a return code of 1 indicated that warnings were present, but this is no longer supported. This change may impact on automated launch scripts that leverage the warning return code.
- Added support for magnetic scalar potential computations of models consisting of cuboids.
- Improved the power calculations for sources of PCB current data.
- Resolved warnings and slow computations while creating the interpolation table, at some frequencies, in an example with layered media.
- Included an error check that thick coatings and shielding are not allowed on the same label.
- Fixed a floating point exception during the calculation of irradiation coupling into a cable harness.
- When solving large problems and employing shared memory it is possible to exceed the shared memory allocation limits for the specific system and architecture of the simulation cluster. This may result in memory errors. A note has been added to the output to indicate when this situation may arise.
- User-defined loads, in the SPICE circuit, are now considered during wideband crosstalk calculations.
- When using a `.str` file, the transfer function memory size estimation is no longer written to the `.out` file. This information is redundant.
- Improved error reporting in parallel solutions including cables. In some cases, not all errors and related triangle numbers required to isolate the error may have been reported.

- Changed the naming of `.ep1` output files to be consistent with the naming convention of other ASCII files exported by the kernel.

Support Components

Feature

- Adjusted the license checks for various Feko components to optimise communication with the license server.

Resolved Issues

- Fixed a bug in the parsing of field data of a Cartesian boundary from Feko Solver (`.efe/.hfe`) files when using all data blocks.
- Improved the removal of temporary files with `.ol` and `.os` extensions on completion of the simulation when running ADAPTFEKO.

WinProp 2022 Release Notes

The most notable extensions and improvements to WinProp are listed by component.

General

Feature

- Added new air interface files to the examples, to cover standards 802.11af and 802.11ax, as well as several 5G bands.

Resolved Issues

- Removed the creation of the `.msu` file association to WinProp to avoid conflicts with `.msu` files used for Microsoft system updates.
- In the calculation of scattering at rough surfaces, ensured a smooth transition between angular ranges.

ProMan

Features

- Added support for a hybrid SBR/SRT solver with improved accuracy over the standard SBR solver of previous releases.
- Added support to display the antenna patterns of transmitters within the 3D view.
- Added a column with the antenna downtilt to the list of antennas in the **Site** dialog.
- Implemented a better interpolation of antenna gain patterns in simulations.
- Implemented multi-threading for Urban Intelligent Ray Tracing (Urban IRT).
- Added the ability to define moving groups within ProMan and via the API, in addition to the existing capability in WallMan.
- Added support for Doppler shift due to movement and rotation in any direction and around any axis in 3D.
- Added the ability to modify the maximum number of polygons to be considered for SRT acceleration. There is a memory trade-off and most users can keep the default.
- Added `.wst` files for the IEEE 802.11ax and 802.11aj standards in the set of examples that is shipped with the installation.

Resolved Issues

- Breakpoint effects at individual pixels along a dominant path are now correctly considered, resulting in accuracy improvements in DPM results in some regions of a database.
- Removed the option to cancel determination of further rays if free space loss is reached as it is no longer relevant for accelerating IRT computations in urban scenarios.

- Improved accuracy of urban scenario predictions by correctly accounting for the shifted height of transmitters above buildings.
- Resolved an issue that resulted in vegetation loss being incorrectly considered at prediction heights well above the vegetation objects during predictions with the dominant path model.
- Improved the accuracy of indoor IRT simulations by robustly handling duplicate rays.
- Resolved a bug that resulted in a missing MIMO stream when a MIMO site is defined using the **Set site** option.
- Improved accuracy of rural propagation by switching from single to double precision storage of some critical parameters.
- Implemented the calculation of Doppler shift for transmitters and prediction points moving along trajectories in otherwise-stationary geometries.
- Fixed a slight difference in indoor DPM results between regular indoor and hybrid urban/indoor models by avoiding a small pixel offset in the latter scenario.
- Corrected the calculation of the breakpoint distance in urban scenarios when the prediction height is specified as absolute height above sea level instead of above ground.
- Fixed a situation in urban scenarios with topography where the determination that a result pixel is inside a building might be incorrect.
- Resolved a crash in a CNP project, solved with IRT, with the transmitter located inside the indoor database.
- Consolidated ray tracing acceleration options between SBR and SRT.

WallMan

Features

- Added support for conversion of several 3D file formats: Autodesk `.3ds` and `.fbx`, COLLADA `.dae`, GL Transmission `.gltf` and `.glb`, Blender `.blend`.
- Added support for database export in the NASTRAN file format.

AMan

Feature

- Improved antenna-pattern generation in AMan, GUI and API, both for single beams and for 5G patterns.

Resolved Issue

- Improved the dipole antenna pattern that is shipped with the examples.

Application Programming Interface

Features

- Added support for predictions on building surfaces with the API.
- Added API functions to export geometry data to binary formats.
- Added a function, `WinProp_Net_Project_Open_WST`, to the network planning API, that reads and generates air interface parameters from a wireless standard file (`.wst` file).
- Added the ability to define moving groups within ProMan and via the API, in addition to the existing capability in WallMan.
- Added support for FMCW radar post processing to the API.
- Added support for preprocessing of time-variant databases with the API.
- Added support for preprocessing of CNP databases with the API.
- Added support for mobile station post-processing and network planning for prediction planes in the WinPropCLI.
- Added support for post-processing, using RunMS, in WinPropCLI.
- Added support for optionally generating a database in ASCII format during database conversion.

newFASANT 2022 Release Notes

The most notable extensions and improvements to newFASANT are listed by component.

General

Feature

- Usage of the CBFM in the MoM module is now supported for non-RCS simulations.

Solver

Resolved Issue

- Resolved a segmentation fault in the Ultrasound module where a crash occurs when a surface is defined for four equal points.

WRAP 2022 Release Notes

The most notable extensions and improvements to WRAP are listed by component.

General

Features

- For collocation interference, enabled the import of a Touchstone file to specify the coupling loss matrix.
- Updated the Area-Mode Longley Rice model to include the variability calculation. Updated the Point-to-Point Mode Longley-Rice model to include the terrain profile.
- Added support to convert GeoTIFF data into native WRAP geodata format.
- It is now possible to select, edit, export, show in map viewer, and delete multiple coverage comparison results.
- Trajectory is included as a calculation area type. It is possible to simulate a receiving antenna that moves along a pre-defined path with given velocity, yaw, pitch and roll.
- Added a vertical interference diagram to the Profile Viewer to visualize in the point-to-point link the impact of changes in antenna heights.
- Added support to import/export frequency characteristics of transmitters, receivers, and filters.
- Added to the Cost and Coverage Optimizer the possibility for the user to view the present best configuration during on-going optimization, and to end the optimization cleanly if desired.
- Implemented the option Terrain Height Peak in the API.
- It is now possible to change the terrain code colors in profile view.
- Removed the obsolete option **Convert Access Database...** from the ChangeDB utility.

Resolved Issues

- Resolved an issue that caused NaN values for a specific settings with the Obstruction Manager.
- Fixed a crash that could occur when no propagation model was selected in the Advisor and the user pressed OK.
- Fixed a crash that could occur if a transmission-loss coverage calculation with Detvag90 is attempted with a "receiver only" station.
- Fixed bugs that set indoor and clutter loss to zero for certain combinations of propagation models and WRAP tools. The propagation models are ITU-R P.370, P.452, P.526, P.2001/P.368, the Extended Two-Ray Model and external models. The WRAP tools are Interference, Radio Calculator, Separation Distance Calculator and Link Check. Also, fixed a bug that set the indoor loss to zero in ITU-R P.1546 for all WRAP tools.
- Prevented unintended repositioning of geostationary satellites that could occur by invoking the time-control bar.
- Fixed a bug in the calculation of the ITU-R P.1812 building loss and the addition or not of the indoor loss from the landcover database.
- Avoided a crash when no propagation model is selected with the Radar Coverage tool.

- Defined a new default path for GeoData: C:\ProgramData\Altair\Feko\shared\WRAP\GeoDB. It remains independent of the installed Feko version.
- Resolved an issue that omits the additional attenuation in Radio Link Performance tool when effective earth radius (EER) is modified.
- The separation distance calculator for the Longley-Rice model now distinguishes between the terrain-dependent version for point-to-point mode and the terrain-independent version for area mode.
- Fixed a bug due to which a wind mill in ObsMan could be interpreted and displayed as just a mast without blades.
- Discontinued the function **Convert Access Database** in ChangeDB as it had become obsolete.
- Corrected a bug in the reading of the drag coefficient B^* in satellite orbits.
- Added a progress window in the Broadcast tool for a process that could take time if many stations are present.
- Result plots of C/I for satellites with zero interference will be clipped at 999 dB to avoid unrealistic values.
- Fixed a crash that could occur if a result was deleted during computation followed by Exit without Save.
- Added the option Terrain Height Peak to radar coverage simulations.
- The best available terrain resolution is now always used by the Coverage tool, rather than it being a user option.
- Resolved a bug in the export of result types Best Server and Number of Servers to .kml format.
- Implemented a progress bar for the import of stations from a file.
- Fixed a bug in the calculation of dense-urban clutter according to ITU-R P.2108-0 3.1.

WRAP MapDataManager

Features

- Added support to export WRAP topographical databases to ASCII Grid format.

Resolved Issues

- A warning will now be issued if the resolution of an imported map is incompatible with WRAP's MapDataManager.

WRAP FM

Features

- Removed the obsolete **Terrain Profile** menu to generate/edit terrain profile manually.
- Provided easy backup and restore options for all Geo data in the Geo Classes dialog.
- Implemented the option to select and export all result layers of a radar volume simulation.

Altair Feko 2021.2.4 is available with new features, corrections and improvements. This version (2021.2.4) is a patch release that should be applied to an existing 2021 installation.

This chapter covers the following:

- [Feko 2021.2.4 Release Notes](#) (p. 171)
- [WinProp 2021.2.4 Release Notes](#) (p. 173)
- [newFASANT 2021.2.4 Release Notes](#) (p. 175)

Feko is a powerful and comprehensive 3D simulation package intended for the analysis of a wide range of electromagnetic radiation and scattering problems. Applications include antenna design, antenna placement, microstrip antennas and circuits, dielectric media, scattering analysis, electromagnetic compatibility studies including cable harness modelling and many more.

WinProp is the most complete suite of tools in the domain of wireless propagation and radio network planning. With applications ranging from satellite to terrestrial, from rural via urban to indoor radio links, WinProp's innovative wave propagation models combine accuracy with short computation times.

newFASANT complements Altair's high frequency electromagnetic software tool (Altair Feko) for general 3D EM field calculations, including, among others, special design tools tailored for specific applications like complex radomes including FSS, automated design of reflectarrays and ultra-conformed reflector antennas, analysis of Doppler effects, ultrasound systems including automotive or complex RCS, and antenna placement problems. Advanced solver technologies like the MoM combined with the characteristic basis functions (CBFS), PO/GO/PTD, GTD/PO and MLFMM parallelised through MPI/OpenMP, being some of them especially efficient for the analysis of electrically very large problems.

Feko 2021.2.4 Release Notes

The most notable extensions and improvements to Feko are listed by component.

CADFEKO

Feature

- The skin depth calculator included in the POSTFEKO application macro library is now also available in CADFEKO.

POSTFEKO

Resolved Issue

- Corrected the mesh triangle IDs displayed on annotations in the 3D view for elements using the faceted UTD solution method.

Solver

Feature

- The memory footprint for models using MLFMM with localised multiple dielectric regions has been reduced.

Resolved Issues

- Improved the accuracy of MoM/RL-GO simulations of models with waveguide ports.
- Resolved a bug that resulted in Feko hanging if an internal error is issued during the iterative solution phase of a parallel MLFMM simulation of some models.
- Resolved a floating point error during the iterative solution phase of a parallel MLFMM solution. The occurrence of this floating point error was hardware dependent.
- Resolved an issue that led to incorrect results when solving a model, with multiple media junctions, with the uncoupled domain Green's function method.
- Resolved an issue that resulted in passivity violations in S-parameter results of a coupled radiation and irradiation MTL solution of a model consisting of cables.
- Reverted simplifications in the calculation of quantities related to cable harness, introduced in the 2021 version, and improved the robustness of combined MoM/MTL solutions.
- Resolved an issue that resulted in the shield transfer impedance being incorrectly set to zero when only a single frequency point is defined in a model consisting of a shielded cable.
- Improved the robustness of cable path intersection checks during the solution of models with cable harnesses.
- Resolved a slowdown while creating the interpolation table in an example with layered media.

- The MLFMM fast near field computation is computed in chunks where memory resources are insufficient.
- Improved calculation of transmission coefficients for some simulation using periodic boundary conditions (PBC).

Shared Interface Changes

Resolved Issue

- Resolved a crash in CADFEKO and POSTFEKO when calling the `close` method on the `Application` object via automation.

Support Components

Features

- Added an application macro to iteratively apply adaptive mesh refinements based on error estimates to assist in achieving a refined mesh.
- Added a chunk parameter to the **Farm model to cluster** application macro. This parameter controls how many sub models are created to farm to a cluster.

Resolved Issues

- A warning is now issued when high-order effects are included in faceted UTD model. A parsing error was issued by previous versions of PREFEKO.
- Fixed a problem causing the **Create HyperStudy extraction script** not to execute correctly.
- Corrected the **Generate Antenna Array** application macro so that wire ports are not removed when using the simplify option.

WinProp 2021.2.4 Release Notes

The most notable extensions and improvements to WinProp are listed by component.

General

Resolved Issues

- Improved the accuracy of SBR predictions by robustly accounting for all transmission effects.
- Corrected the computation of transmitter height in the COST model for the case where topography data are used and the transmitter is on top of a building.

ProMan

Features

- The computation of the MIMO condition numbers has been extended for higher order MIMO systems, for example, 4x4 or 8x8.
- The transmission mode corresponding to the maximum data rate has been added to the `.dda` and `.dua` files.
- Improved the parallel scaling of predictions of project with multiple transmitters using a large number of threads.

Resolved Issues

- Fixed a crash that occurred in trajectory mode and in point mode in time-variant projects with the transmitter moving along a trajectory.
- Fixed a crash that could occur when **Generate per-stream and sub-channel power results** was requested under **Postprocessing incl. Tx and Rx**.
- Resolved a crash when a cable with 3 points is moved with **Move Component** tool.
- Resolved an issue that prevented displaying propagation results for an Urban model with GPS satellites.
- Corrected the unit for the resolution of prediction results when geodetic coordinates are used.
- Reduced memory usage of multi-threaded simulations with the dominant path model.

WallMan

Resolved Issues

- Resolved an issue with IRT preprocessing of an outdoor database that leads to duplicate rays diffracted from the common wedge of two buildings.
- Fixed an error message that could appear when drawing a correct polyline object.

- Resolved an issue that caused a missing shape in an indoor IRT model when a database was preprocessed while the option **Additionally prediction of outdoor pixels** was enabled.

Application Programming Interface

Features

- Added support for Motley-Keenan model with the WinPropCLI.
- Added support for conversion of indoor databases to urban databases as well as conversion of urban to indoor using WinPropCLI.

newFASANT 2021.2.4 Release Notes

The most notable extensions and improvements to newFASANT are listed by component.

GUI

Feature

- Corrected the phase information in the ray tracing output file of the US module.

Resolved Issues

- Resolved an issue that resets the rotation parameters for the Doppler calculation in the PO/GTD-PO modules.
- Extended the newFASANT US module to add support for selection of specific effects (such as direct, reflected, diffracted, and transmitted rays) and to exclude rays that are longer than a selected distance while computing Coupling.

Solver

Feature

- Corrected the phase information in the ray tracing output file of the US module.

Resolved Issues

- Corrected the transmitted ray component for dielectric objects in the GTD module.
- Resolved an issue that resets the rotation parameters for the Doppler calculation in the PO/GTD-PO modules.
- Extended the newFASANT US module to add support for selection of specific effects (such as direct, reflected, diffracted, and transmitted rays) and to exclude rays that are longer than a selected distance while computing Coupling.
- Resolved an issue with reading radiation pattern for coupling computation in the US module.

Altair Feko 2021.2.3 is available with new features, corrections and improvements. This version (2021.2.3) is a patch release that should be applied to an existing 2021 installation.

This chapter covers the following:

- [Feko 2021.2.3 Release Notes](#) (p. 177)
- [WinProp 2021.2.3 Release Notes](#) (p. 179)
- [newFASANT 2021.2.3 Release Notes](#) (p. 181)

Feko is a powerful and comprehensive 3D simulation package intended for the analysis of a wide range of electromagnetic radiation and scattering problems. Applications include antenna design, antenna placement, microstrip antennas and circuits, dielectric media, scattering analysis, electromagnetic compatibility studies including cable harness modelling and many more.

WinProp is the most complete suite of tools in the domain of wireless propagation and radio network planning. With applications ranging from satellite to terrestrial, from rural via urban to indoor radio links, WinProp's innovative wave propagation models combine accuracy with short computation times.

newFASANT complements Altair's high frequency electromagnetic software tool (Altair Feko) for general 3D EM field calculations, including, among others, special design tools tailored for specific applications like complex radomes including FSS, automated design of reflectarrays and ultra-conformed reflector antennas, analysis of Doppler effects, ultrasound systems including automotive or complex RCS, and antenna placement problems. Advanced solver technologies like the MoM combined with the characteristic basis functions (CBFS), PO/GO/PTD, GTD/PO and MLFMM parallelised through MPI/OpenMP, being some of them especially efficient for the analysis of electrically very large problems.

Feko 2021.2.3 Release Notes

The most notable extensions and improvements to Feko are listed by component.

POSTFEKO

Features

- Added support for setting the independent axis of a surface graph to a swept parameter when plotting parameter sweep results.
- Added a new script to the POSTFEKO application macro library which allows the import of simulation results from newFASANT projects to be imported and processed as custom data.

Resolved Issues

- Resolved an issue where an assertion failure could be triggered when plotting characteristic mode results on a Cartesian graph and switching the independent axis to **Mode index (untracked)**. This fix resolves the problem for results calculated with much older versions of Feko, while an improvement made to Feko 2020.1.2 already prevents a similar assertion failure from triggering when plotting results from more recent versions.
- Resolved an issue that caused negative axis values to be returned incorrectly as “untracked” values when using the API to query available axis values.
- Fixed a regression that got introduced in Feko 2021.1.1 that caused incorrect half power beamwidth (HPBW) annotations for polar graphs.
- Lifted the restriction that triangle normals need to point in the same direction for the tool that indicates mesh connections where a certain included angle is exceeded.
- Added case-sensitive checks to prevent an assertion from failing when calling API functions like `GetFixedAxisValue` with the axis string specified incorrectly, for example, using “theta” instead of “Theta”.
- Resolved an issue with Cartesian graph annotations that caused the annotations to be positioned at the wrong location, or not added to the graph at all, for some interpolated trace values.

Solver

Resolved Issues

- Resolved MPI errors observed during certain RL-GO solutions on a machine with shared memory architecture.
- Resolved an internal error that may have occurred during the parallel MLFMM solution for some models.
- A change introduced in Feko 2021.1 resulted in a small reduction in accuracy for simulations involving wire segments. This has been corrected.

- Improved the accuracy of the computed charges for models including some degenerate curvilinear triangles, solved with high order basis functions.

WinProp 2021.2.3 Release Notes

The most notable extensions and improvements to WinProp are listed by component.

ProMan

Features

- Improved and accelerated the detection of convex wedges for diffraction calculations.
- Accelerated SBR simulations in projects with a large number of transmissions in the propagation path.
- Improved load balancing of parallel SBR simulations, resulting in improved parallel efficiency and faster simulation times.
- ASCII output, when requested, will now include all requested points, including those where no result could be computed (for example, where no communication was possible).
- Added support for adding time-variant transmitters and prediction points in urban IRT simulations.
- For transmitters or prediction points moving along a curved trajectory but not exactly on the trajectory, such as antennas on aircraft wings, rotation is now included in a natural way relative to a moving reference point on the trajectory.

Resolved Issues

- Resolved an issue where a connector component could be missing after closing and reopening the project.
- Visibility relations between stationary and dynamic objects are now accurately considered in time-variant IRT simulations of indoor projects.
- Resolved a crash in a project where **consider scattering at ground** was enabled while **consider additionally rays with scattering** was disabled.
- Resolved an issue around power superposition of cells belonging to the same distributed antenna system during network planning.
- Improved the initial detection of objects that will be hit by shooting and bouncing rays (SBR), so no object larger than the maximum ray tube width or height will be overlooked by the rays that were launched from the transmitter.
- Improved the existing transmitter height correction for transmitters that are accidentally placed inside a building in an urban scenario.
- Improved the visualization of trajectory results for time variant projects. Now all the points on a trajectory for a given time step are shown simultaneously.
- Resolved an issue with the consideration of scattering loss that cause a higher gain than expected.
- Prevented the occurrence of small random differences in the results of repeated simulations with the parabolic equation solver.
- Relaxed an error into a warning during `.kml` file export from small topo maps with ellipsoid coordinate system other than WGS-84.

- Improved the display of results in urban IRT projects where the pre-processing had been done with a resolution factor greater than one. The necessary interpolation between available result pixels is applied.
- Resolved a case of missing animation frames for a time-variant project with topography data.

WallMan

Resolved Issues

- Improved the robustness of object triangulation in databases containing closed polygons.
- Visibility relations between stationary and dynamic objects are now accurately considered in time-variant IRT simulations of indoor projects.
- Improved geometry checks involving wedges in a database, leading to accuracy improvements of predictions using the DPM, SRT and IRT methods.
- Corrected the trajectory definition in WallMan using ALD mode. Objects now move in the right direction.

Application Programming Interface

Features

- Default ground material properties can now be specified via the WinProp API.
- Added an example on how to use the API for network planning with the 5G-TDD communication protocol. This example is distributed with the installation.
- Added support for predictions along surfaces in indoor databases with the API.
- Add support for predictions on arbitrary planes with the WinProp API.

Resolved Issue

- Resolved an issue where network throughput results computed by WinPropCLI on Linux could not be viewed with ProMan on Windows.

newFASANT 2021.2.3 Release Notes

The most notable extensions and improvements to newFASANT are listed by component.

General

Features

- Near-field data calculated on a Cartesian boundary in Feko and saved as `.efe` and `.hfe` files may now be imported into the newFASANT interface and used as an excitation for simulations with newFASANT solvers.
- Added a new script to the POSTFEKO application macro library which allows the import of simulation results from newFASANT projects to be imported and processed as custom data.

GUI

Resolved Issue

- When a NASTRAN file is imported into newFASANT and rotated, the visualisation of the imported geometry will now remain correct if the project is closed and reopened. For projects created in versions where this bug was present, geometry will have to be re-imported for the visualisation to be correct.

Solver

Resolved Issues

- Resolved an issue in the GTD module where creeping rays could not be resolved for specific near field points.
- The computed transmission of rays using the newFASANT GTD solver will no longer incorrectly calculate null amplitude transmission for some cases.
- Resolved a segmentation fault in the PO module where a crash occurs for specific observation directions with specific number of processors.

Altair Feko 2021.2.2 is available with new features, corrections and improvements. This version (2021.2.2) is a patch release that should be applied to an existing 2021 installation.

This chapter covers the following:

- [Feko 2021.2.2 Release Notes](#) (p. 183)
- [WinProp 2021.2.2 Release Notes](#) (p. 185)
- [newFASANT 2021.2.2 Release Notes](#) (p. 188)

Feko is a powerful and comprehensive 3D simulation package intended for the analysis of a wide range of electromagnetic radiation and scattering problems. Applications include antenna design, antenna placement, microstrip antennas and circuits, dielectric media, scattering analysis, electromagnetic compatibility studies including cable harness modelling and many more.

WinProp is the most complete suite of tools in the domain of wireless propagation and radio network planning. With applications ranging from satellite to terrestrial, from rural via urban to indoor radio links, WinProp's innovative wave propagation models combine accuracy with short computation times.

newFASANT complements Altair's high frequency electromagnetic software tool (Altair Feko) for general 3D EM field calculations, including, among others, special design tools tailored for specific applications like complex radomes including FSS, automated design of reflectarrays and ultra-conformed reflector antennas, analysis of Doppler effects, ultrasound systems including automotive or complex RCS, and antenna placement problems. Advanced solver technologies like the MoM combined with the characteristic basis functions (CBFS), PO/GO/PTD, GTD/PO and MLFMM parallelised through MPI/OpenMP, being some of them especially efficient for the analysis of electrically very large problems.

Feko 2021.2.2 Release Notes

The most notable extensions and improvements to Feko are listed by component.

CADFEKO

Feature

- Improved the functioning of volume mesh refinement rules. Point refinement rules will now take effect when completely embedded inside a region. Before, the refinement region had to touch or cross a face to have any effect.

Resolved Issue

- Corrected a problem where the far field source was written out incorrectly to the `.pre` file when changing a far field data definition from using a specified point range to using all data blocks. The simulation seemingly ignored the updated setting.

POSTFEKO

Resolved Issues

- Resolved the following issues with polar graph zoom levels:
 - Polar graph zoom levels did not persist in saved projects (`.pfs` files).
 - Zooming to extents on polar graphs did not respect the radial grid range settings.
 - Newly created polar graphs were not zoomed to extents for all graph range settings.

Solver

Feature

- An error is now given if a twisted pair with an unrealistically short pitch length is specified in a cable definition.

Resolved Issues

- Resolved a bug in near and far field computations of faceted UTD models, resulting in accuracy improvements.
- The model setup time of a faceted UTD simulation is now reported under the “Reading and constructing the geometry” entry of the timing section at the end of the `.out` file.
- Resolved a bug that led to inaccurate results when calculating near fields from a request that only contains the magnetic near field with the scattered field only option.
- Reduced the impact of a change made in the Feko 2021.2.1 patch update that resulted in slower simulations when many wire segments were included.

- Corrected a slowdown in the solution of some simulations using periodic boundary conditions (PBC).
- Fixed a bug in the parallel MLFMM fast far fields when a translation (OF card) is present.
- Accelerated and improved the parallel efficiency of near field computations by reducing the communication overhead in parallel simulations with a large number of processes.
- Fixed an exception during the ray launching phase of RL-GO when using an aperture source and parallel solution.
- Revised the check for the validity of a combined MoM/MTL solution of an unshielded cable to include unbounded cross-sections whose dielectric material is the same as that of the background medium.

Shared Interface Changes

Feature

- Limited the display frequency of the license expiration notice to once per day instead of every time a component is launched.

Support Components

Resolved Issue

- Relaxed the check for the version of the existing Feko installation, to enable the installation of WRAP 2021.2 into a patch updated version of Feko.

WinProp 2021.2.2 Release Notes

The most notable extensions and improvements to WinProp are listed by component.

ProMan

Features

- It is now possible to globally define the TDD configuration for all the cells from the **Air Interface** tab of a 5G project in ProMan.
- Added support for yaw/pitch/roll angle transformations applied to time variant objects.
- Added support for preprocessing multiple heights for urban databases.
- Site name and cell name are now included in the respective text files for network projects solved with the trajectory mode.
- Added support for the extended cyclic prefix for 5G network planning projects.
- Added support for a user-defined maximum inner angle of wedges to be included in diffraction computations with SBR/SRT. This value can be used to accelerate SBR/SRT predictions, depending on the geometry of the objects in the database.

Resolved Issues

- Resolved a bug that resulted in higher than expected received power results when one switches transmitter settings from OutputPA to EIRP in a fully polarimetric project with a horizontally polarised `.ffe` antenna pattern, created in AMan, at the transmitter.
- The ground reflected ray is now accounted for in the main lobe of the transmitter when gain adaptation is activated in the SBR solver.
- Resolved an issue that resulted in reflection contributions not being computed when the maximum number of transmissions is set to one in the SBR solver.
- Prevented exceptionally high memory usage during wedge detection in a complicated geometry.
- Resolved an issue that reflection was included although only scattering was requested in the SRT propagation model.
- Fixed a bug in the computation of ground clutter.
- Improved the robustness and accuracy of the SBR solver by further preventing rays from slipping through wedges into buildings or other objects in the database.
- Optional additional vector data, such as roads, rivers and railway lines, are now displayed below the buildings and result planes.
- Resolved an error that prevented execution of RunMS in a UWB network planning project.
- Avoided a RunMS error when a transmitter located inside an urban building was automatically shifted to the roof of the building.
- Resolved a bug that resulted in the first time step of a time-variant simulation being displayed multiple times in the drop-down menu.
- Resolved an issue that caused vegetation objects still being displayed in a project after being disabled.

- Corrected the display location in urban scenarios of transmitters that had to be shifted upward automatically to avoid placement inside buildings.
- Resolved an issue related to a inability to close the mobile post-processing, including Tx and Rx, dialog box after cancelling computation.

WallMan

Features

- Added support for yaw/pitch/roll angle transformations applied to time variant objects.
- Added support for preprocessing multiple heights for urban databases.
- The centre of the focused 2D view is now suggested as the location of an imported database, in WallMan, by default so that the imported database is immediately visible to a user.

Resolved Issues

- Deleted walls are now removed from their associated object groups.
- Resolved an issue that caused velocities in the definition of a time-variant trajectory to be shifted by one segment.
- Group of objects defined in .dxf or .dwg files are now preserved when converted to the WinProp binary database format.
- Resolved an issue that resulted in the absence of segment to segment visibility relations during IRT preprocessing of some indoor databases in WallMan.
- Improved the calculation of the rotation of a moving object. The center of rotation is now used to calculate the angle by which the object is to be rotated, instead of the center of the moving object.
- An error message is now issued when the absolute path for the preprocessing output file does not exist.
- Wall-Check settings, specified under Global Settings, will be saved.
- Resolved an issue that result in an object moving out of its trajectory, defined in RAC mode, in a time-variant simulation.
- Resolved a bug where a higher number of threads than specified were used during indoor IRT preprocessing. This resulted in increased license usage.

AMan

Resolved Issue

- Added support for sub-one degree pattern resolutions for antenna patterns in the MSI format.

Application Programming Interface

Feature

- Added support for UWB network planning projects with WinPropCLI.

Resolved Issues

- Resolved an issue that caused warnings to be triggered when compiling WinProp API examples on Linux.
- Resolved an issue where network planning results were incorrectly marked as not computed, when a project simulated with WinPropCLI is opened in ProMan.
- Resolved inconsistencies in the requirement to include the file extension when converting databases into the WinProp binary format using the API. The file extension is now automatically appended if it was not supplied by a user.

newFASANT 2021.2.2 Release Notes

The most notable extensions and improvements to newFASANT are listed by component.

General

Feature

- When launching a newFASANT project using RUNFEKO, the output indicates when options that are not supported for newFASANT solvers are passed to RUNFEKO.

Resolved Issues

- When solving a problem using RT-CBFM with MPI, the MPI is now always launched correctly.
- An assert no longer is triggered when using Volume Based Blocks for the CBFM.

Altair Feko 2021.2.1 is available with new features, corrections and improvements. This version (2021.2.1) is a patch release that should be applied to an existing 2021 installation.

This chapter covers the following:

- [Feko 2021.2.1 Release Notes](#) (p. 190)
- [WinProp 2021.2.1 Release Notes](#) (p. 192)
- [newFASANT 2021.2.1 Release Notes](#) (p. 194)

Feko is a powerful and comprehensive 3D simulation package intended for the analysis of a wide range of electromagnetic radiation and scattering problems. Applications include antenna design, antenna placement, microstrip antennas and circuits, dielectric media, scattering analysis, electromagnetic compatibility studies including cable harness modelling and many more.

WinProp is the most complete suite of tools in the domain of wireless propagation and radio network planning. With applications ranging from satellite to terrestrial, from rural via urban to indoor radio links, WinProp's innovative wave propagation models combine accuracy with short computation times.

newFASANT complements Altair's high frequency electromagnetic software tool (Altair Feko) for general 3D EM field calculations, including, among others, special design tools tailored for specific applications like complex radomes including FSS, automated design of reflectarrays and ultra-conformed reflector antennas, analysis of Doppler effects, ultrasound systems including automotive or complex RCS, and antenna placement problems. Advanced solver technologies like the MoM combined with the characteristic basis functions (CBFS), PO/GO/PTD, GTD/PO and MLFMM parallelised through MPI/OpenMP, being some of them especially efficient for the analysis of electrically very large problems.

Feko 2021.2.1 Release Notes

The most notable extensions and improvements to Feko are listed by component.

CADFEKO

Resolved Issue

- Improved the meshing of spiral structures to more accurately represent the geometry. In the past, in some cases, non-adjacent points in the spiral would be connected in the mesh.

POSTFEKO

Resolved Issues

- Resolved an issue with the recently added support to view and process far field, near field and other results generated during S-parameter calculations (where the SP card option in EDITFEKO is enabled before calculation). For models with multiple configurations, some results could have been wrong or missing.
- Resolved a problem that caused unpredictable Ctrl+Click selection of result palette entries.
- Fixed a regression that got introduced in POSTFEKO 2019.2 where the iso-surface plot type was no longer available for spherical near fields.
- Added unit information to indicate that the amplitude is plotted in dB when previewing spectrum of a time domain signal.
- Resolved an issue where the message `Warning 18219: The medium has been referenced (used), but it was never declared. Please correct the model by creating a suitable definition for the medium.` was encountered due to media with identical properties being incorrectly merged. The media merging will now only occur when it is relevant.
- Resolved the problem that the visibility of mesh segment lines could not be toggled through the API.

Solver

Features

- Reduced the memory footprint of the linear equation solution phase of a simulation by exploiting shared memory architecture.
- Added a warning regarding the validity of braided shield models with respect to frequency.
- Added user warnings in cases where a cable's cross-section may violate MTL rules.
- Added support for the PARAMS keyword in the .SUBCKT syntax of a SPICE netlist.

- Reduce the number of low level MPI communications needed during far field calculation phases. This results in reduced far field calculation times and better scaling when the number of processes increase.

Resolved Issues

- Detect stagnation during an iterative solution, where the process of reducing the residuum stops progressing and the iterative process should be exited instead of running to the maximum number of iterations.
- Resolved an issue that resulted in the inability to visualise rays, from some faceted UTD models with creeping wave effects, in POSTFEKO.
- An error message is now issued when simulating a model consisting of a material with zero permittivity.
- For HOBf improve the segmentation error message given when a triangle is too large. A warning is added that higher order basis functions cannot be used at connection points or junctions (even if the user has specified HOBf on these triangles).
- Correct results are now calculated when using Periodic Boundary Conditions for cases where the boundaries are electrically very close to each other.

WinProp 2021.2.1 Release Notes

The most notable extensions and improvements to WinProp are listed by component.

ProMan

Features

- Accelerated the transmission mode computation for 5G network planning projects.
- Improved the display of courtyards in 2D and 3D view.

Resolved Issues

- Resolved an error that occurred when using the post-processing option that includes transmitters and receivers, with individual location offset arrays used on both the base and mobile stations.
- Resolved a high-memory-consumption problem that could occur in simulations with complicated geometries.
- Added support for mobile station post-processing, using RunMS, in projects with satellite transmitters.
- Made the settings dialog of the spatial channel impulse response accessible.
- Preprocessed CNP projects, exported from ProMan, now include the indoor database.

WallMan

Features

- Added support for triangulating selected objects. This can repair/replace objects that would otherwise be considered invalid, such as non-planar ones.
- Preprocessing projects, including indoor/urban databases as well as any associated secondary data such as topography maps, can be exported from WallMan as a ZIP archive.
- Added support to convert an indoor database (.idb) to an outdoor database (.odb).

Resolved Issues

- Resolved an issue with IRT preprocessing when the walls are not perfectly planar.
- Resolved an issue when converting a NASTRAN file to an indoor database format.
- Resolved an error that could occur upon opening a pre-processing project with a relative file path.
- Resolved an issue that led to horizontal plates being assigned negative heights after conversion from OpenStreetMap via a .odb urban database into a .idb indoor database.
- Resolved a problem that occurred during preprocessing when vegetation blocks are partly outside the topography area.

AMan

Resolved Issue

- An explanatory error message is issued when the transmission loss of a material in the MASC module exceeds 200 dB and produces unacceptable path loss.

Application Programming Interface

Feature

- Added support for moving transmitters or receiving points along trajectories in rural and urban scenarios in the WinProp API.

Resolved Issues

- Made the sorting of object IDs consistent between Windows and Linux.
- Added support for simulations of projects using the ITU P.1546, ITU P. 526 or ITM propagation models with the WinPropCLI.
- Updated the C# structures in the API.

newFASANT 2021.2.1 Release Notes

The most notable extensions and improvements to newFASANT are listed by component.

GUI

Resolved Issue

- When the newFASANT graphical interface fails to resolve a newfasant.conf file at startup, a default configuration is generated and used. Previously this process wrote an error message to the output before continuing, which may have been misleading. A note with a clearer message is now written to the output.

Solver

Feature

- By combining Ray-Tracing techniques with CBFM, an approach has been added where the optimal number of macro-basis functions is used for each block for the specific problem. This approach minimizes the number of unknowns while maintaining accuracy.

Resolved Issues

- Fixed a bug that resulted in a simulation error during an array resizing operation in the PO module when multiple reflections and diffraction are considered.
- Resolved several problems that caused unexpected asymmetry of reflected rays when using the US module.
- Resolved various problems with the MIMO option when working with the GTD module.

Altair Feko 2021.2 is available with new features, corrections and improvements. It can be applied as an upgrade to an existing 2021 installation, or it can be installed without first installing Altair Feko 2021.

This chapter covers the following:

- [Highlights of the 2021.2 Release](#) (p. 196)
- [Feko 2021.2 Release Notes](#) (p. 200)
- [WinProp 2021.2 Release Notes](#) (p. 203)
- [newFASANT 2021.2 Release Notes](#) (p. 205)

Feko is a powerful and comprehensive 3D simulation package intended for the analysis of a wide range of electromagnetic radiation and scattering problems. Applications include antenna design, antenna placement, microstrip antennas and circuits, dielectric media, scattering analysis, electromagnetic compatibility studies including cable harness modelling and many more.

WinProp is the most complete suite of tools in the domain of wireless propagation and radio network planning. With applications ranging from satellite to terrestrial, from rural via urban to indoor radio links, WinProp's innovative wave propagation models combine accuracy with short computation times.

newFASANT complements Altair's high frequency electromagnetic software tool (Altair Feko) for general 3D EM field calculations, including, among others, special design tools tailored for specific applications like complex radomes including FSS, automated design of reflectarrays and ultra-conformed reflector antennas, analysis of Doppler effects, ultrasound systems including automotive or complex RCS, and antenna placement problems. Advanced solver technologies like the MoM combined with the characteristic basis functions (CBFS), PO/GO/PTD, GTD/PO and MLFMM parallelised through MPI/OpenMP, being some of them especially efficient for the analysis of electrically very large problems.

Highlights of the 2021.2 Release

The most notable extensions and improvements to Feko, WinProp and newFASANT in the 2021.2 release.

Salient Features in Feko

- When visually inspecting the mesh in POSTFEKO, a new tool has been added to highlight edges between mesh elements where the joining angle exceeds a certain threshold. Careful consideration of the angles between mesh elements is particularly useful when employing the faceted UTD solver, where there will be an impact on the optical effects that will be considered at that edge depending on angle. By default, a joining angle exceeding 210° will result in the edge being treated as a diffracting edge rather than an artefact from meshing of a smooth or gradually curving surface.

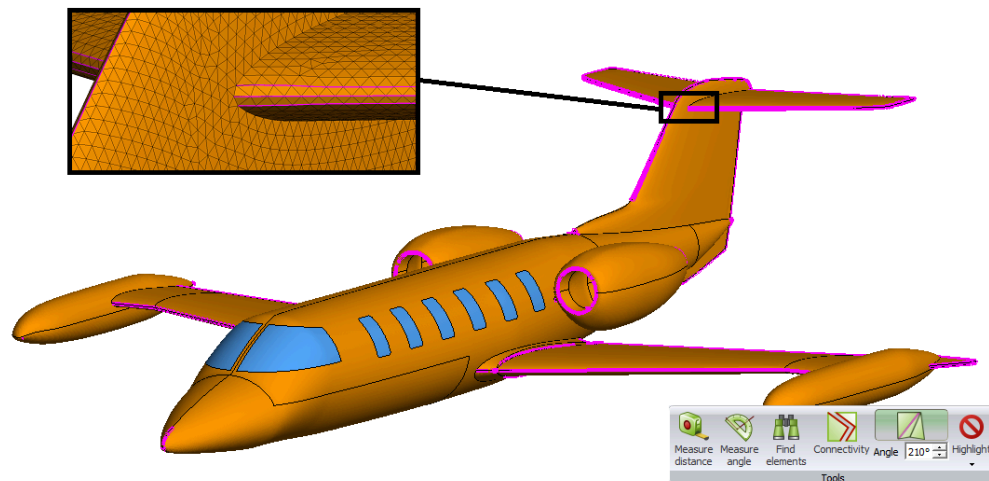

Figure 40: Highlighting mesh elements in POSTFEKO where the angle between the elements exceeds a threshold.

- For iterative solutions involving FEM, the residuum that is monitored to determine convergence now uses the true residuum of the original system of linear equations rather than the pseudo-residuum of the preconditioned system of linear equations. This provides better feedback and avoids cases of premature convergence, where the pseudo-residuum could be some orders of magnitude larger than the true residuum. The default target residuum levels for the FEM/MoM and FEM/MLFMM solvers have been adjusted, while preserving similar or better solution accuracy to previous releases.
- Quantities such as near fields, far fields and currents can now be calculated as part of an S-parameters calculation. The requested values are calculated for each combination of port excitation and loading during the S-Parameter loop.

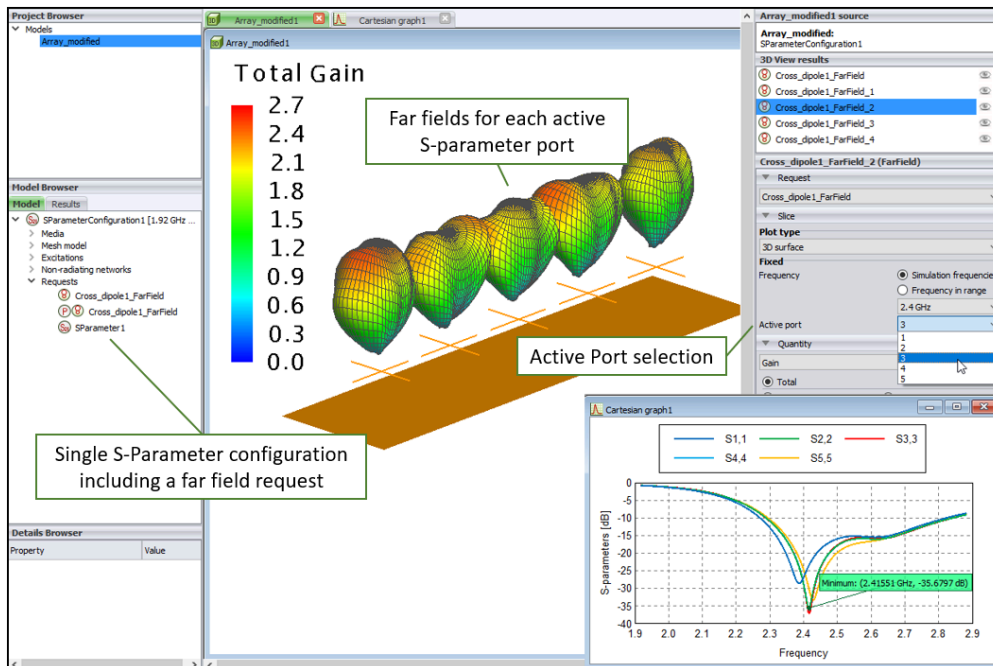

Figure 41: A cross dipole array illustrating the visualisation of the embedded element radiation patterns calculated as part of a single S-parameter configuration.

- Various licensing improvements have been made. Borrowing of licenses is now supported and a retry option is available to reconnect to a license server without quitting ongoing actions in the event that connection to the license server is lost (for example during a network interruption).

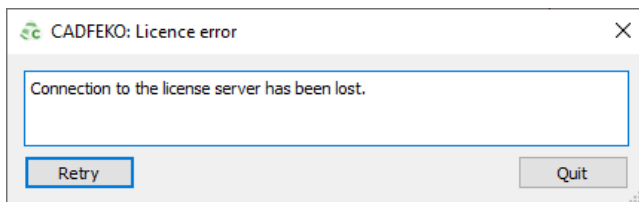

Figure 42: A retry button allows re-establishing the connection to a license server in the event of a break in network communication, without having to quit the application.

Salient Features in WinProp

- Added a new simulation method based on Shooting and Bouncing Rays (SBR) that is particularly efficient when many ray interactions per ray need to be included, or the geometry has many small facets. The settings and results of SBR are very similar to those of Standard Ray Tracing (SRT). An example in which more than a handful of ray interactions are needed is in tunnel scenarios and for time-variance with trajectories, as shown in Figure 43. This is also useful to simulate communication between two aircraft in flight or to simulate vehicle-to-vehicle communication.

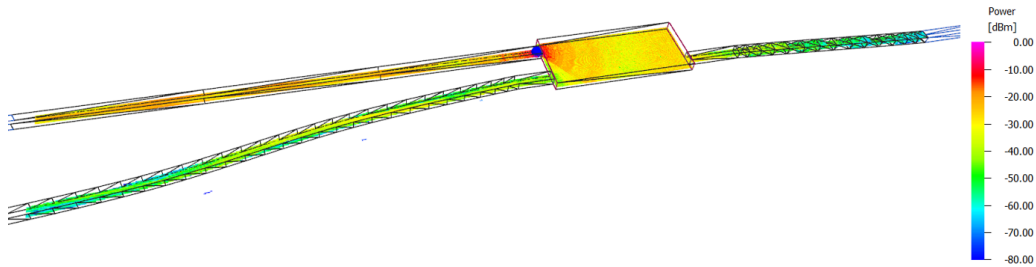

Figure 43: An example of multiple tunnels and a station.

- Added support for a transmitter or a receiving point to move in time along a trajectory in ProMan, without the need to connect it to a moving object. Velocities and orientations can vary along the trajectory.

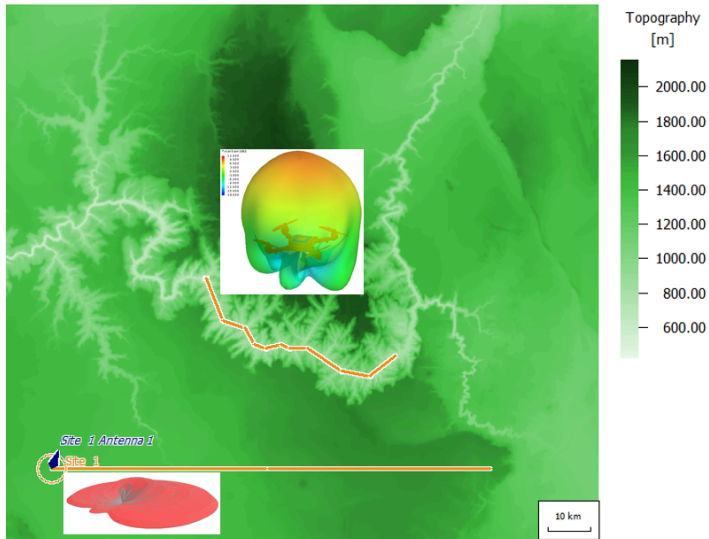

Figure 44: An example of multiple aircraft communicating in flight - a transmitter and receiver moving along a trajectory as a function of time.

Salient Features in newFASANT

- newFASANT projects may now be launched using runfeko. This integration enables easier solution of newFASANT projects for users familiar with runfeko and simplifies using existing scripts and queueing system configurations prepared for other Feko solvers.

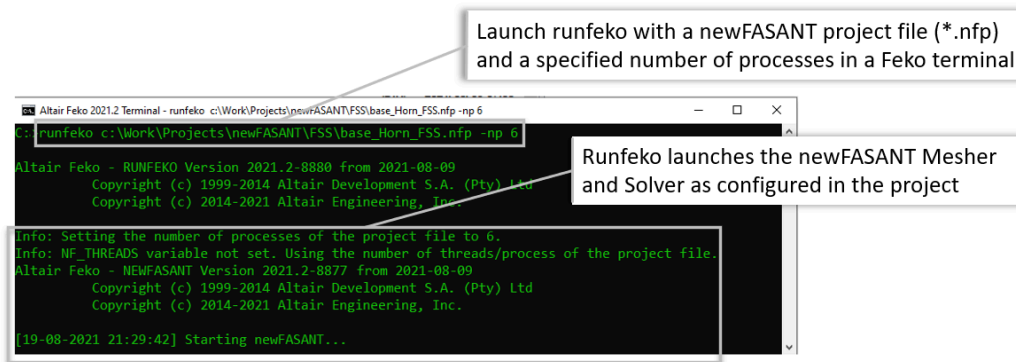

Figure 45: Meshing and solving a newFASANT project from the Feko terminal using a standard runfeko command.

- By combining ray-tracing techniques with CBFM, a novel approach has been added where the optimal number of macro-basis functions is determined for each block based on a ray-tracing analysis. This approach minimizes the number of unknowns while maintaining accuracy.

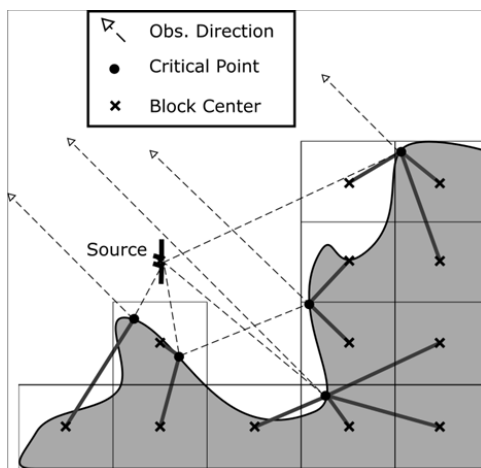

Figure 46: Using ray-tracing to determine critical points and optimize the number of macro-basis functions needed per block for a specific source point and observation direction in a solution using the CBFM.

Feko 2021.2 Release Notes

The most notable extensions and improvements to Feko are listed by component.

CADFEKO

Features

- Added a simplified quadcopter model to the component library.
- When running CADFEKO_BATCH the same number of license units will now be checked out as for the CADFEKO GUI.
- Upgraded the meshing library to the latest version.

Resolved Issues

- Resolved a problem that caused an assertion to fail when using the **Specified points** definition method for a near field request together with the option to activate the FDTD solver.
- Resolved a problem that caused an assertion to fail when defining far field data, selecting **Use all data blocks** and browsing for a file.
- Resolved an issue on the **Define far field data** dialog where the file browser file extension filter listed `.dat` files instead of `.ffe` files.
- When generating multiple solution coefficient source files for different configurations, the correct data is now written to the different files.
- Adjusted the wording and options on the **High frequency** tab of the **Solver settings** dialog to be more consistent for the different methods (UTD, RL-GO and PO).
- Made adjustments to the **Solver settings** dialog so that it fits on all screens within the supported range of screen resolutions.

EDITFEKO

Features

- Added the **Calculate all result requests** option to the **SP - Calculate S-parameters for active sources** card. When this option is selected, other result requests (near fields, far fields and so forth) will be calculated for each port excitation/loading scenario included in the S-parameter calculation.
- Extended the AP and RA cards with the option to use all data blocks when importing near fields (from `.efe/.hfe`, `.nfd` or `.mfxml` file).

POSTFEKO

Features

- Added API support for adding overlay images to 2D graphs. The **AddChartImage**, **AddChartImageFromFile** and **AddChartImageForTrace** methods allow automation of the actions of the **Chart image** button on the **Display** tab.
- Increased the `.fek` file version to 182 to accommodate new features.
- Added support to view and process far field, near field and other results generated during S-parameter calculations (where the new SP card option in EDITFEKO is enabled before calculation).
- Added support for showing coatings on faces. Previously POSTFEKO supported the display of wire coatings only.
- Added a tool for indicating mesh connections where a certain included angle is exceeded. In the **Tools** group of the **Mesh** tab under the **3D View** contextual tab set, enter the angle of interest and click the **Angle** icon to activate/deactivate the highlighting. This tool is useful for viewing where diffraction effects will be considered when using faceted UTD.

Solver

Features

- Allow for the combination of multiple aperture field definitions into a single near field source.
- Added support for multiple frequency definition and usage in near field sources and receiving antennas.
- Result requests, such as near or far fields, SAR, and so forth, can now be processed as part of an S-parameter configuration.
- Improved the quality of error estimates around FEM line ports resulting in more robust and convergent results obtained through adaptive mesh refinement.
- For the iterative solvers involving FEM, the true residuum of the original system of linear equations is now used to determine convergence rather than the pseudo-residuum of the preconditioned system. This provides better feedback and avoids premature convergence for some cases. As a result of this improvement, the default target residuum levels for the FEM/MoM and FEM/MLFMM have been raised, while maintaining similar or better solution accuracy. A fixed error threshold level is now used to identify critical non-convergence.
- Removed the SECFEKO legacy licensing system from the Feko components. Support for legacy licensing ended with the release of Feko 2019. Only Altair licensing is supported going forward with no exception.

Resolved Issues

- Resolved an issue that prevented simulation of a model with a PCB source from proceeding past the geometry checking phase.
- Resolved an internal error state that was issued when solving a model with a solution coefficients source that includes dielectric basis functions.

- Resolved an issue that led to an incorrectly issued error message during the geometry processing phase of the solution.
- An explicit error message is now issued for a decoupled MoM and FEM simulation of a model with periodic boundary conditions.
- Resolved an error state that occurred when restoring FEM port loads, with an attached non-radiating network, after an S-parameter calculation.
- Improved the robustness of coaxial waveguide port mode expansion computations with respect to higher order modes. These improvements resolve possible floating point exception errors that may occur due to divisions by zero.
- Resolved an issue that resulted in asymmetric near field results in a model solved with MLFMM.

Shared Interface Changes

Features

- Added a **Retry** button to the **License error** dialog. This dialog is displayed when the connection to the license server is lost. Instead of the application closing following this event, re-establishing the connection to the license server can now be attempted.
- Extended the **Archive** namespace so that the contents of a `.zip` file can be read and selected items extracted without inflating the whole archive.

Support Components

Features

- Extended the **Import WinProp trajectory results** application macro to support the batch import of multiple trajectory results based on a re-usable index file.
- A new Feko Errors, Warnings and Notes Reference Guide is now available in PDF and HTML. It can be used as a reference for messages that may be encountered in Feko. The PDF and HTML are available at <Altair/2021.2/help/feko/messages>.
- Removed unnecessary information that may have been shown between square brackets at the end of the version strings of various components.

Resolved Issues

- Resolved an issue with borrowed licenses not working for RUNFEKO, PREFEKO and CADFEKO_BATCH.

WinProp 2021.2 Release Notes

The most notable extensions and improvements to WinProp are listed by component.

General

Features

- Increased the maximum limit of memory used for 3D view rendering using DirectX. This limit is machine dependent.

ProMan

Features

- Added support for simulations in which a transmitter or a receiving point moves in time along a trajectory in ProMan, without the need to connect it to a moving object. Velocities and orientations can vary along the trajectory.
- Added the capability to compute area-mode results at multiple heights in rural/suburban scenarios within one simulation.
- For more flexibility in time-variant simulations with moving objects, a trajectory can now also be read from the `.net` project file.
- Added supported for circularly polarized transmitters and receivers.
- Added support for ground scattering predictions based on ground clutter coefficients.
- Added the capability to compute area-mode results at multiple heights in urban scenarios within one simulation.
- Added support for excluding a subset of the available prediction trajectories or prediction points in a project.
- Added support for Doppler shift computations for trajectory based time-variant scenarios.
- Results from multiple trajectories can now be simultaneously displayed in ProMan.
- Sub-channel power results can be accessed and displayed from the result tree.
- Rotation of receiving antennas on a mobile station is now applied according to the group (objects or trajectory) the receiving antennas are attached to.
- Implemented measures to ensure a smooth variation of scattered power, computed from rough surfaces, as a function of frequency.
- Added a new simulation method, based on Shooting and Bouncing Rays (SBR), to the palette of available methods. This method is particularly efficient when many interactions per ray need to be included, or when the geometry has many small facets.

Resolved Issues

- Added API support for horizontal and slant polarisation definitions at the transmitter.

- Standardised the path separator used when exporting projects so that exported projects, including those with an EMC specification file, can readily be simulated on Windows and Linux.
- Resolved a crash when simulating an urban project with pixel vegetation objects.
- Resolved a bug that resulted in higher than expected received power results when one switches transmitter settings from OutputPA to EIRP in a fully polarimetric project with a horizontally polarised `.ffe` antenna pattern, created in AMan, at the transmitter.
- Implemented trajectory preprocessing when importing a trajectory from a text file in order to avoid trajectory point duplicates. Additionally resolved an issue that resulted in NaN values being generated for trajectory results with points whose velocity is 0 m/s.
- Resolved an issue that led to incorrect broadcasting results when considering superposition from multiple carriers within CNP buildings in a combined indoor-urban scenario.

WallMan

Resolved Issues

- The sub-division dialog was suppressed depending on direction in which the sub-division is drawn in WallMan. This has been resolved.
- Set the maximum limit of pixels, in a pixel topographical database (`.tdb`) that can be converted to a vector database (`.tdv`), to 10 million.

AMan

Resolved Issues

- Resolved an issue that resulted in a slightly higher gain when converting a `.msi` pattern to a polarimetric pattern in a linear polarisation angle other than 0 or 90 degrees.

Application Programming Interface

Features

- Added support for the SBR solver in the API.
- Added support for moving transmitters or receiving points along trajectories in the WinProp API.

newFASANT 2021.2 Release Notes

The most notable extensions and improvements to newFASANT are listed by component.

General

Features

- Added support for hybrid MPI/OpenMP simulations of CBFM models with ACA compression.
- Accelerated the generation of CBFs in models with large blocks or a high density of subdomains, by using the **Hierarchical PWS** option in the **CBFs Properties** dialog. A speed-up factor of 2x or more is achievable.
- By combining Ray-Tracing techniques with CBFM, an approach has been added where the optimal number of macro-basis functions is used for each block for the specific problem. This approach minimizes the number of unknowns while maintaining accuracy.

GUI

Features

- Added an option to choose separately direct or reflected rays in the GTD module.
- Disabled curvature meshing on PO surfaces of PO/GTD-PO models with multiple bounces.

Solver

Features

- Added an option to choose separately direct or reflected rays in the GTD module.

Resolved Issues

- Resolved an issue in the GTD module where certain coupling simulations may have given an unexpected null coupling error and aborted prematurely.

Altair Feko 2021.1.2 is available with new features, corrections and improvements. This version (2021.1.2) is a patch release that should be applied to an existing 2021 installation.

This chapter covers the following:

- [Feko 2021.1.2 Release Notes](#) (p. 207)
- [WinProp 2021.1.2 Release Notes](#) (p. 209)
- [newFASANT 2021.1.2 Release Notes](#) (p. 211)

Feko is a powerful and comprehensive 3D simulation package intended for the analysis of a wide range of electromagnetic radiation and scattering problems. Applications include antenna design, antenna placement, microstrip antennas and circuits, dielectric media, scattering analysis, electromagnetic compatibility studies including cable harness modelling and many more.

WinProp is the most complete suite of tools in the domain of wireless propagation and radio network planning. With applications ranging from satellite to terrestrial, from rural via urban to indoor radio links, WinProp's innovative wave propagation models combine accuracy with short computation times.

newFASANT complements Altair's high frequency electromagnetic software tool (Altair Feko) for general 3D EM field calculations, including, among others, special design tools tailored for specific applications like complex radomes including FSS, automated design of reflectarrays and ultra-conformed reflector antennas, analysis of Doppler effects, ultrasound systems including automotive or complex RCS, and antenna placement problems. Advanced solver technologies like the MoM combined with the characteristic basis functions (CBFS), PO/GO/PTD, GTD/PO and MLFMM parallelised through MPI/OpenMP, being some of them especially efficient for the analysis of electrically very large problems.

Feko 2021.1.2 Release Notes

The most notable extensions and improvements to Feko are listed by component.

CADFEKO

Feature

- Avoid re-meshing and storage of unnecessary model files for the RCS farming application macro when it is not required.

Resolved Issues

- Fixed a regression that got introduced in Feko 2021.0.3 that caused a crash when opening a file with non-ASCII Unicode characters in the file path.
- Resolved an issue where the RL-GO edge and wedge diffraction setting was not written to the `.pre` file and therefore not taken into account during simulation.
- Fixed an error in the automatic calculation of the outer radius between two shields when defining a cable cross-section in a CADFEKO model using a model unit other than meters.

POSTFEKO

Features

- Added command line support to the **Combine RCS sweep results from cluster** macro to support a non-interactive mode that can be used to combine the results directly on the simulation cluster.
- Extended the POSTFEKO API with the `ContinuousFrequencyAxis` property on various result data types to allow querying whether axes are continuous (as opposed to discrete). This is useful, for example, to evaluate whether an axis can be resampled.

Resolved Issues

- Resolved an issue where the ribbon was not updated following the removal of a model. Selecting a button that was incorrectly enabled, for example, one of the buttons in the **Add results** group, could cause an assertion to fail.
- Improved the conditional test used by the **Generate antenna array** script to determine the FEM line port edge properties. An error is avoided for the case of an empty wire collection.

Solver

Features

- Added support for waveguide ports in the model decomposition framework.
- Improved AVX/AVX2 support detection for some older AMD CPU's.

Resolved Issues

- Resolved a floating point exception that was issued when computing cable per-unit-length parameters due to the presence of degenerate curvilinear triangles in the mesh of the cable cross-section.
- Resolved passivity violations in S-parameter results of some models with windscreens consisting of multiple media.
- Resolved an issue that led to asymmetry in far field results of some models solved with MLFMM.
- Resolved an issue that resulted in inaccurate results of a direct solution (using LU decomposition) of some windscreen models with multiple media.
- Improved the accuracy of faceted UTD results due to reflections from concave surfaces.

Support Components

Features

- Extended the **Calculate mixed mode S-parameters** application macro to support calculation for N-port cases. Previously this was limited to 4 ports.

Resolved Issues

- Linux support for the PolEx REI file pre-processing script in the application macro library has been improved.

WinProp 2021.1.2 Release Notes

The most notable extensions and improvements to WinProp are listed by component.

ProMan

Features

- Added time stamps to the log files written by ProMan as well as standard output from WinPropCLI.
- Accelerated the database partitioning phase of a simulation with the dominant path model.
- Added support for exporting FMCW radar signal processing results to an ASCII file.

Resolved Issues

- Resolved an issue that led to the creation of corrupted databases, in some cases, during database conversion from the open street map format. Potentially corrupted databases obtained using previous versions of WinProp may need to be converted using this version.
- Resolved an issue regarding the height of prediction points for indoor projects solved with DPM model in trajectory or point mode.
- Resolved an issue that resulted in wrong signal levels associated with propagation paths when switching display from one result type to another.
- Resolved a crash that occurred during the geometry processing phase of a DPM solution of an indoor scenario project with a large database.
- Resolved an issue when building and topography databases have a different earth curvature. The error message is converted into a warning message.
- Resolved an issue about selecting prediction layers in a loaded project in which the local setting **Display all prediction layers** had been checked.
- Relaxed an error message to a warning, in an IRT simulation, when the total sum of the numbers of reflections, diffraction and scattering is less than the user-defined maximum number of reflections and diffraction in a path.
- Removed unnecessary warning messages for an indoor project.
- Resolved an issue that resulted in a factor of 10 being applied to topography heights after masking.
- Resolved an issue that resulted in the inability to activate legend display, after it was disabled, through the local display settings menu.
- Resolved an issue that resulted in the inability to activate legend display, after it was disabled, through the local display settings menu.
- Resolved an issue when the prediction area is larger than the preprocessed area for RunMS simulations.
- Fixed a rare case where plotting the Channel Impulse Response (CIR) could result in an infinite loop.
- Resolved a simulation error that occurred in a project with negative topographical heights, simulated with the ITU-R P.1411 propagation model.

WallMan

Resolved Issues

- Resolved an issue that led to the creation of corrupted databases, in some cases, during database conversion from the open street map format. Potentially corrupted databases obtained using previous versions of WinProp may need to be converted using this version.
- Resolved conversion errors that may occur when converting some `.stl` files into the WinProp binary format.

Application Programming Interface

Features

- Added multi-threading support for predictions of rural projects with the WinProp API.
- Added time stamps to the log files written by ProMan as well as standard output from WinPropCLI.
- Added an example with mobile station post-processing to the set of API examples that are distributed with the installation
- Added support for all types of databases in the WinProp API.

Resolved Issues

- Removed unnecessary warning messages for an indoor project.
- Fixed possible discrepancies between Network-Planning settings in the GUI and in the WinProp API.
- Resolved a topo database conversion failure from the ASCII line format into the standard binary format using the WinProp API.
- Fixed a crash that could occur when using WinPropCLI with a large number of threads.

newFASANT 2021.1.2 Release Notes

The most notable extensions and improvements to newFASANT are listed by component.

GUI

Feature

- RUNFEKO can now be used to launch newFASANT simulations.

Resolved Issue

- Resolved an issue which prevents aborting a mono-static RCS calculation with many directions in the MONCROS module.
- Added support for importing NASTRAN mesh files consisting of curved elements of type CTRIA6 and CQUAD8. Resolved an issue that led to errors when importing some meshes in the NASTRAN format.

Solver

Features

- Improved the parallel efficiency of OpenMP based multi-threaded MLFMM solutions.
- Removed the limitation of the distance between antenna and radome structure in the analysis of radomes using CBFM.

Release Notes: Altair Feko 2021.1.1

24

Altair Feko 2021.1.1 is available with new features, corrections and improvements. This version (2021.1.1) is a patch release that should be applied to an existing 2021 installation.

This chapter covers the following:

- [Feko 2021.1.1 Release Notes](#) (p. 213)
- [WinProp 2021.1.1 Release Notes](#) (p. 216)
- [newFASANT 2021.1.1 Release Notes](#) (p. 218)

Feko is a powerful and comprehensive 3D simulation package intended for the analysis of a wide range of electromagnetic radiation and scattering problems. Applications include antenna design, antenna placement, microstrip antennas and circuits, dielectric media, scattering analysis, electromagnetic compatibility studies including cable harness modelling and many more.

WinProp is the most complete suite of tools in the domain of wireless propagation and radio network planning. With applications ranging from satellite to terrestrial, from rural via urban to indoor radio links, WinProp's innovative wave propagation models combine accuracy with short computation times.

newFASANT complements Altair's high frequency electromagnetic software tool (Altair Feko) for general 3D EM field calculations, including, among others, special design tools tailored for specific applications like complex radomes including FSS, automated design of reflectarrays and ultra-conformed reflector antennas, analysis of Doppler effects, ultrasound systems including automotive or complex RCS, and antenna placement problems. Advanced solver technologies like the MoM combined with the characteristic basis functions (CBFS), PO/GO/PTD, GTD/PO and MLFMM parallelised through MPI/OpenMP, being some of them especially efficient for the analysis of electrically very large problems.

Feko 2021.1.1 Release Notes

The most notable extensions and improvements to Feko are listed by component.

CADFEKO

Features

- Added validation for setting faceted UTD on faces. Only PEC faces where the associated region is PEC or free space can be solved using the faceted UTD solution method. Faceted UTD only supports planar triangle meshing.
- The size of the `.fek` file is significantly reduced when multiple receiving antennas use the same field data.
- Added the **Ideal power divider** application macro in CADFEKO. The application macro generates a network model of an ideal n-port power divider with unequal division, a 2-port Wilkinson power divider with unequal division or an n-port Wilkinson power divider with equal division.
- Added the **Create far field equivalent sources split over frequency** application macro in CADFEKO. This application macro creates multiple configurations that each contain a far field equivalent source for a single frequency. Run the **Combine far field equivalent sources** application macro in POSTFEKO to combine the results for the configurations.

Resolved Issues

- Resolved an assertion failure that got triggered when unlinking a mesh and opting to create new ports if the part contained a FEM line port applied to a SEP region.
- Resolved an assertion failure with the message `!m_connectedNets.contains(pNet)` when closing an existing model containing a degenerate net in a cable schematic. This was a regression that got introduced in Feko 2021.
- Fixed a regression that got introduced in Feko 2021.1 that caused performance issues when adding, modifying or removing requests.
- Resolved an issue affecting waveguide sources, where unlinking a mesh and selecting to use new ports did not update the source to use the newly created mesh port.
- Resolved an issue where a Cartesian boundary near field request sampled inside an object instead of on the boundary.
- Resolved an issue where mesh versions of the modal ports were not created when unlinking a mesh.

EDITFEKO

Resolved Issues

- Fixed incorrect syntax highlighting of colours for `.pre` files containing non-ASCII characters.

POSTFEKO

Features

- The mesh highlight tool is extended with the **Faceted Uniform Theory of Diffraction** option for highlighting faces in the 3D view that are solved with the faceted UTD method.

Resolved Issues

- Resolved an assertion failure with the message `Assertion failed: contains(value)` when trying to create a plot in the 3D view of a result that uses the spherical coordinate system, but does not contain any values in the plotted range.
- Resolved an issue where additional (unrequested) load results were available in models with multiple configurations utilising series loads.
- Resolved an assertion failure with the message `frequencyIndex < m_stack.last().m_numberOfFrequencies` when exporting far fields to `.ffe` file for a model containing multiple configurations with different frequency settings in the different configurations.
- Resolved an issue with annotations on Cartesian graphs where the annotation arrow and coloured area would be incorrect and appear to be disconnected from the trace after enabling **Normalise to ... maximum of all traces** on the **Display** tab.
- Resolved an issue with annotations where the value did not update when the display unit changed due to changes made to the graph, like showing or hiding another trace with a different range.

Solver

Features

- Reduced the memory footprint of parallel simulations of Faceted UTD models.
- Improved the parallel performance of the iterative solution of linear equations phase of a simulation with MLFMM.
- Reduced the required memory usage of the iterative solution of linear equations during a simulation of a model with multiple media with MLFMM. The extent of memory reduction is model dependent.
- Accelerated the iterative solution of linear equations phase of an MLFMM solution of models with multiple dielectric media. Additionally, reduced the memory footprint of this phase of the solution.
- The relative error of the iterative solution is now reported in the `.out` file as well as standard output in cases where the solution has not sufficiently converged and a few additional iterations are required to monitor the solution's behaviour before determining whether the iterative solution has failed or not.

Resolved Issues

- Resolved an issue that resulted in inaccuracies when power scaling is applied in a faceted UTD solution.
- Resolved an internal error that may occur during the matrix fill stage of a model consisting of more than one windscreen definition.

- Resolved an issue that resulted in inaccuracies when computing quantities, such as S-parameters, associated with a FEM line port that is not oriented in a main Cartesian axis.
- Disabled MPI3 shared memory usage with MPICH and MS-MPI on Windows as it is not supported.
- Corrected an error message for a FEM line port that is confined to the edges of the mesh. Improved the error detection for FEM line ports.
- Changed the error regarding surface roughness parameter bounds into a warning.
- Fixed a bug that caused a segmentation violation for some models that use many aperture sources (AP card).
- Improve the performance of the configuration setup phase of the solution of a model that uses an aperture field, with many field points, as source. The performance improvements are noticeable when such a simulation is done on Windows.
- Improved the performance and robustness of a faceted UTD solution involving multiple reflections.
- Lossy metallic triangles connected to wire segments are now exported to the .ep1 file.

Support Components

Resolved Issues

- Resolved an issue on Linux systems where the icons on the **Documentation** tab of the Launcher utility were missing.

WinProp 2021.1.1 Release Notes

The most notable extensions and improvements to WinProp are listed by component.

General

Resolved Issues

- A user-defined UTM zone can now be specified when converting GeoTIFF topo maps.

ProMan

Features

- Added support for RunMS post-processing in CNP scenarios.
- Added support for RunMS predictions along a trajectory defined in a CNP database.
- Added the capability to produce bit error rate (BER) maps using SNIR values.
- Increased the maximum number of reflections supported by the urban IRT propagation model from 6 to 20.
- The transmit power type (OutputPA, EIRP, ERP) is now displayed for each antenna on the **Site** dialog.
- Added support for angle of arrival estimation using FMCW radar signal processing.
- Added support for naming individual trajectories.
- With the inclusion of a more sophisticated scattering algorithm, the deterministic scattering parameters that belonged to the previous implementation were removed from the GUI.

Resolved Issues

- Resolved an issue that resulted in errors when using a large preprocessed SRT database.
- The radiating cable losses as well as frequency-dependent amplification or attenuation factors are now correctly considered during link budget analysis.
- Fixed a crash that could occur in a hybrid urban/indoor (CNP) IRT simulation.
- Exact reproducibility of results, from one sequential or parallel run to another, is now possible when statistical clearance is applied to clutter heights.
- Prediction points outside the database polygon, associated with a transmitter, are now ignored.

WallMan

Features

- Enhanced the conversion of Wavefront `.obj` files to WinProp indoor database format to include materials and groups.

Resolved Issues

- Resolved an issue that resulted in errors when using a large preprocessed SRT database.
- Resolved an issue converting a USGS BIL topographical database into native WinProp format.
- Resolved an issue converting topography in Digital Terrain Elevation Data format for high latitudes.

Application Programming Interface

Features

- Added support for network planning of projects with trajectories with the WinProp API.
- Added support for satellite transmitters in the WinProp API.

newFASANT 2021.1.1 Release Notes

The most notable extensions and improvements to newFASANT are listed by component.

General

Resolved Issues

- Resolved an issue for **Speed Up** technique applied to Macro Basis Functions (CBFs) that improves the accuracy of the interpolated field values for some cases.

GUI

Resolved Issues

- Importing geometry from a format such as STP into the newFASANT graphical interface may have failed without feedback when the import file contained an excessive number of faces/surfaces in contact with each other at one point. An error message was added to indicate the reason for this failure.
- Resolved a crash when saving an image of near fields in 3D view.
- Resolved an issue with opening the newFASANT GUI on a remote Linux workstation.

Solver

Features

- Added support for ACA compression during the generation of MoM-derived basis functions, including near field coupling, when using the CBFM.

Resolved Issues

- Importing geometry from a format such as STP into the newFASANT graphical interface may have failed without feedback when the import file contained an excessive number of faces/surfaces in contact with each other at one point. An error message was added to indicate the reason for this failure.

Altair Feko 2021.1 is available with new features, corrections and improvements. It can be applied as an upgrade to an existing 2021 installation, or it can be installed without first installing Altair Feko 2021.

This chapter covers the following:

- [Highlights of the 2021.1 Release](#) (p. 220)
- [Feko 2021.1 Release Notes](#) (p. 223)
- [WinProp 2021.1 Release Notes](#) (p. 226)
- [newFASANT 2021.1 Release Notes](#) (p. 228)

Feko is a powerful and comprehensive 3D simulation package intended for the analysis of a wide range of electromagnetic radiation and scattering problems. Applications include antenna design, antenna placement, microstrip antennas and circuits, dielectric media, scattering analysis, electromagnetic compatibility studies including cable harness modelling and many more.

WinProp is the most complete suite of tools in the domain of wireless propagation and radio network planning. With applications ranging from satellite to terrestrial, from rural via urban to indoor radio links, WinProp's innovative wave propagation models combine accuracy with short computation times.

newFASANT complements Altair's high frequency electromagnetic software tool (Altair Feko) for general 3D EM field calculations, including, among others, special design tools tailored for specific applications like complex radomes including FSS, automated design of reflectarrays and ultra-conformed reflector antennas, analysis of Doppler effects, ultrasound systems including automotive or complex RCS, and antenna placement problems. Advanced solver technologies like the MoM combined with the characteristic basis functions (CBFS), PO/GO/PTD, GTD/PO and MLFMM parallelised through MPI/OpenMP, being some of them especially efficient for the analysis of electrically very large problems.

Highlights of the 2021.1 Release

The most notable extensions and improvements to Feko, WinProp and newFASANT in the 2021.1 release.

Salient Features in Feko

- All file formats used in far field based impressed sources and receiving antenna requests were extended to support multi-frequency data. When used to define an impressed source, automatic interpolation of this source data allows it to be used for simulation at any frequency, enabling more flexible and dramatically simplified model-decomposition workflows.

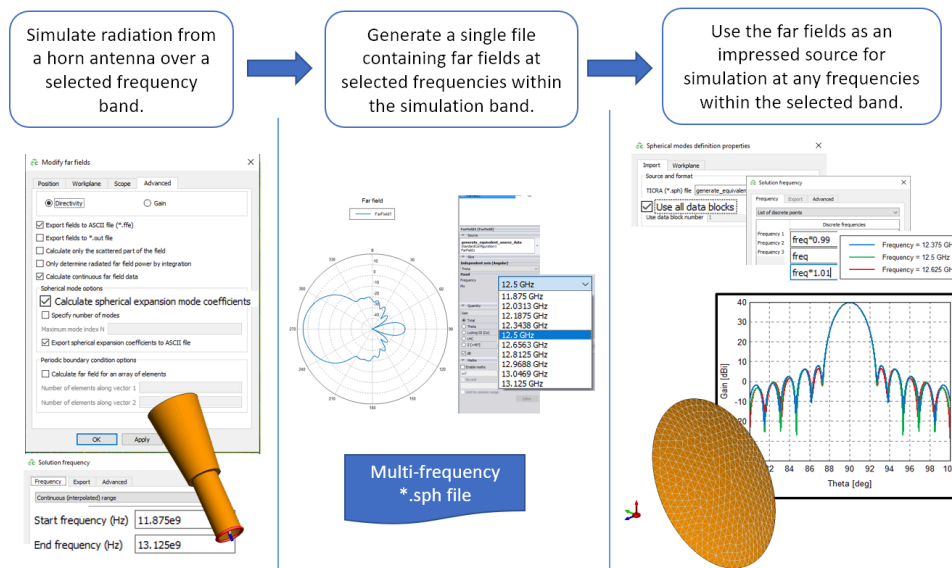

Figure 47: Using a spherical mode representation of a horn antenna pattern as an impressed source for a parabolic reflector to calculate radiation patterns at flexible frequencies.

- Full graphical user interface support added for defining **Model decomposition** requests in CADFEKO. This request can be used to generate solution-coefficient files (.sol) for the solution-coefficient impressed source.

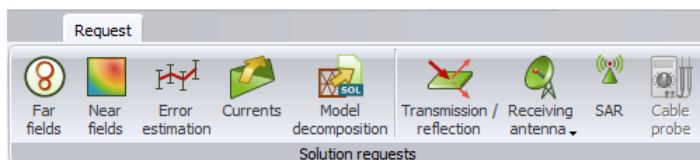

Figure 48: The **Model decomposition** button added to the **Solution requests** group in CADFEKO.

- Added a new UTD-based solver. The faceted UTD solver can be used to calculate fields and radiation patterns for antenna placement applications at high frequencies. It supports impressed sources and a triangular PEC surface mesh. The resource requirements are independent of frequency, but depend on the number of mesh elements required to accurately represent the

geometry and the number of field observation points. Multiple reflections, diffraction and creeping-wave effects are considered. Higher-order effects will be added in future releases.

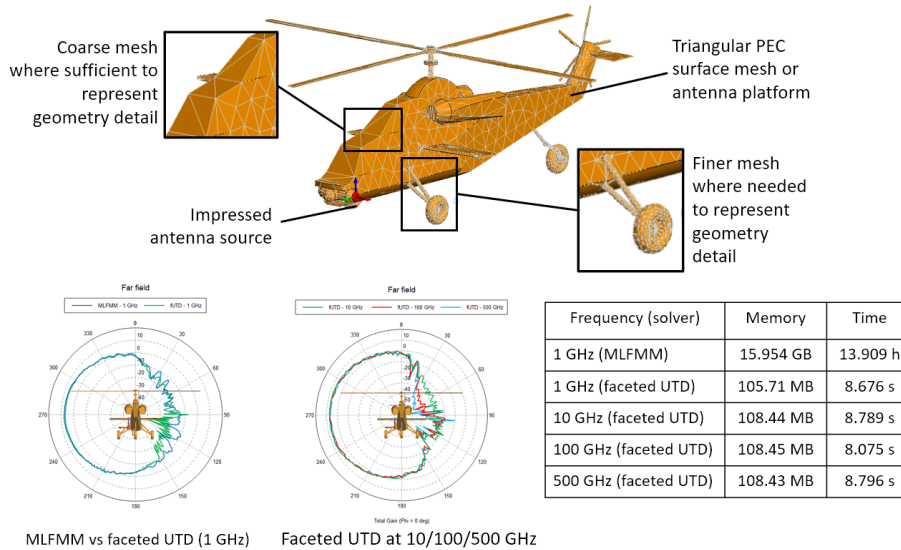

Figure 49: New faceted UTD solver added to Feko for frequency-independent antenna placement analysis.

Salient Features in WinProp

- Added support for frequency-modulated continuous wave (FMCW) radar signal post-processing with a sawtooth waveform which includes the effects of FMCW parameters like chirp duration, sweep bandwidth, number of chirps, and Fourier transformations.
- Added the surface roughness parameter to the **Material Properties** dialog. A new global material catalog binary file (.mcb) was created which contains a default roughness value for each one of the 71 materials, based on measurements from papers or approximations from similar textures.
- Added support for predictions along surfaces in indoor databases. Specify the distance between the wall element itself and the surface prediction planes in front of and behind the wall on the **Object Properties** dialog.

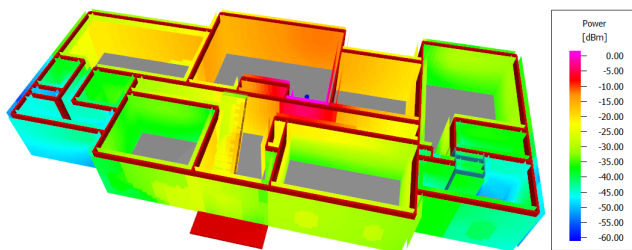

Figure 50: An example of a building with predictions along surfaces.

- Added support for predictions along surfaces in urban databases. Specify the distance between the building itself and the surface prediction planes on the sides of the building on the **Object Properties** dialog.

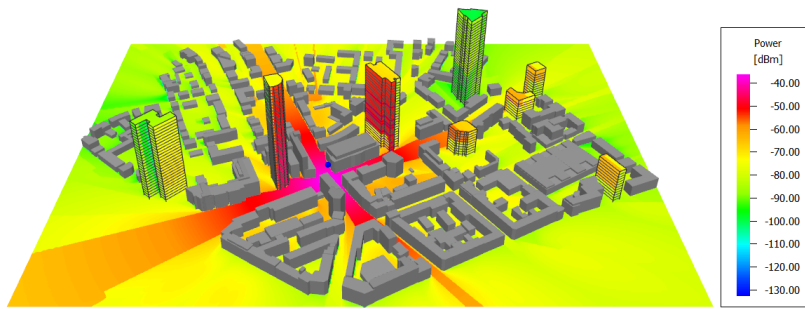

Figure 51: An example of an urban scenario with predictions along building surfaces.

Salient Features in newFASANT

- newFASANT is now available as part of the Altair Student Edition license program. The Altair Student Edition is available from the Altair University website.

Feko 2021.1 Release Notes

The most notable extensions and improvements to Feko are listed by component.

CADFEKO

Features

- Extended SPICE circuit loads with the option to specify the circuit name.
- Added support for an impressed current source to connect to the closest wire segment vertex.
- Added support for the model decomposition workflow using a solution coefficient source.
 - The **Model decomposition request** lets the solver calculate a `.sol` file.
 - The **Solution coefficient data** definition references a `.sol` file and is used by the **Solution coefficient source**.
- Extended far field data and spherical mode data with the option to allow using all data blocks.
- CADFEKO now supports the option to select the dielectric surface impedance approximation as a solution method on dielectric regions. Selecting this setting on a region activates the dielectric surface impedance approximation on all faces which bound that region.
- Extended the **Region properties** dialog with the option to specify the element order for a FEM region locally.
- Added support for faceted UTD. Select **Faceted uniform theory of diffraction (UTD)** from the face or mesh properties dialog to enable the faceted UTD solver. Similar to RL-GO, for faceted UTD the model is meshed into triangles that accurately represent the geometry. Advanced options for faceted UTD can be found on the **Solver settings** dialog, **High frequency** tab.
- Changed the default maximum number of ray interactions for polygonal and cylindrical UTD in CADFEKO from 3 to unspecified (using the Solver defaults unless specified).
- Allow setting an impedance sheet as the medium on wires.

Resolved Issues

- Resolved an issue where the latest Parasolid versions could not be exported through the API.
- Resolved a problem with impressed current sources not taking the workplane definition into account.

EDITFEKO

Features

- Extended the **AV - Impressed current connected to mesh vertex** card with the option to connect to a wire segment.
- Extended the CI card (used to define cable interconnection and termination definitions) with the closed metallic surface connection type.

- Extended the AR, AS and RA cards with the option to use all data blocks when importing `.ffe`, `.ffs` and `.sph` files.
- Added support for faceted UTD to the UT card.

POSTFEKO

Features

- Increased the `.fek` file version to 179 to accommodate new features.
- Added support for the dielectric surface impedance approximation of a dielectric region. The dielectric medium is displayed for faces bounding such a region when **Mesh colour** is set to **Element face media**. The mesh highlight tool is extended with the **Surface impedance approximation** option for highlighting these faces in the 3D view.
- Extended the mesh highlight tool **Impedance sheet** option to include wires.

Resolved Issues

- Resolved an assertion failure that could be encountered when selecting in EDITFEKO to use the dielectric surface impedance approximation of a dielectric region.

Solver

Features

- The matrix fill stage of a solution can now be done in parallel with the ACA solver on a single node.
- Accelerated the geometry processing phase of the FEM solution of a model with a multi-scale mesh.
- Solution coefficient sources can now be connected to geometry or an infinite ground plane.
- Added support for multiple frequency definition and usage in spherical mode expansion files (`*.sph`).
- Added support for point sources or receiving antennas defined using far field patterns consisting of multiple frequency points.
- Improved the parallel performance of the FEM sparse matrix setup phase of the solution. Significant performance gains could be achieved for some large FEM models with many FEM surface unknowns.
- All FEM tetrahedra are now included in the computation of the energy normalisation factor, during error estimation, in order to ensure that consistent error estimate levels are obtained across multiple FEM-related error estimate requests, whether label specific or global.

Resolved Issues

- Fixed a bug that led to inaccurate results when a model with thin dielectric sheet approximation is solved with MLFMM.

Support Components

Features

- Removed the **CoMan** and **OptMan** buttons from the WinProp group on the Launcher utility. These components can still be accessed directly from the installation.
- Added launch buttons for WRAP components to the Launcher utility. WRAP executables are not packaged as part of the Feko 2021.1 installer available through the Altair Marketplace and the WRAP actions on the Launcher utility will remain disabled unless the necessary WRAP executables are added to the Feko installation folder. WRAP actions are always disabled for a Linux installation, where WRAP is not currently supported.
- If WRAP components are copied into the Feko installation folder, the version numbers for these WRAP components can be viewed on the Feko GUI update utility (**Installed versions** tab).

WinProp 2021.1 Release Notes

The most notable extensions and improvements to WinProp are listed by component.

ProMan

Features

- Implemented multi-threading for rural/suburban prediction methods including the Parabolic Equation Solver.
- The calculation of scattering at rough surfaces has been improved, based on recent research.
- Reduced the minimum allowed frequency of materials to 30 MHz.
- Breakpoint effects are disabled by default for new indoor SRT projects. These effects can be activated in the breakpoint menu under SRT settings.
- Added support for MIMO inter-stream interference definition using the envelope correlation coefficient (ECC) of the antenna patterns.
- The unit of the horizontal axis of CDF/PDF graphs of data rate or throughputs is now adapted from the legend of data rate/throughput results. Previously, the horizontal axis was always expressed in bits per second.
- Added an option to visualize results for all prediction layers simultaneously in the 2D view.
- The Propagation Paths window, which appears when the feature Single Display of Rays is invoked, can now be resized.
- The resolution with which imported urban vegetation polygons are adjusted to topography is now a user-defined parameter with a default value of 10 meters.
- Added support for scattering and reflection interaction points in the same ray path computed with SRT.
- Added support for FMCW radar signal processing.
- Added support for predictions along building surfaces in urban scenarios.
- Added support for predictions along surfaces in indoor databases.
- The number of inputs/outputs of combiners/splitters in CompoMan has been increased to eight.

Resolved Issues

- Fixed a bug that led to result power being lower than the ray power for the urban IRT model.
- Resolved an inaccuracy that occurred in SRT when a reflection point of a ray is located on the interface of a vegetation object and a regular object.
- Improved the robustness of the wedge detection algorithm.
- Improved the clarity of the error message that is given when RunMS in a full polarimetric project is executed with an antenna pattern that doesn't contain polarimetric information.

WallMan

Features

- Added support for predictions along surfaces in indoor databases.
- The Materials Catalogue now contains values for surface roughness. These are material dependent and can be modified by the user.

Resolved Issues

- Resolved an issue that prevented saving a database after moving or rotating objects. Additionally improved the geometry processing phase of the solution, resulting in improvements in accuracy in the DPM as well as ray tracing based prediction methods.
- Resolved an issue that prevented objects in an indoor database to be moved to a located where another object had previously been.

CompoMan

Features

- The number of inputs/outputs of combiners/splitters in CompoMan has been increased to eight.

Application Programming Interface

Resolved Issues

- The maximum power at a transmitter is now limited to 100 dBm.
- Fixed a bug that made the API example projects terminate with an error message.
- Updated the C# sample project to use the latest structures.
- The display height written to the binary result file of a point-mode RunMS simulation of a project consisting of topography database, is now correctly written as being relative to the topography.

newFASANT 2021.1 Release Notes

The most notable extensions and improvements to newFASANT are listed by component.

General

Features

- The Speed Up feature in the newFASANT MOM module is now supported when using multiple frequencies and various source types.
- Similar to other Altair Simulation products, a Student Edition license for newFASANT is now available.

Resolved Issues

- An error window has been added indicating the reason for failure when attempting to launch the newFASANT GUI in a remote session or on a system where the required OpenGL version is not supported or available. Previously this may have failed silently.

GUI

Features

- Added support for gain computation and visualisation in the newFASANT GTD module.

Solver

Features

- Added support for gain computation and visualisation in the newFASANT GTD module.
- Included ACA compression for the generation of MoM-Derived basis functions when using the CBFM
- Included ACA compression for the generation of PO-Derived basis functions when using the CBFM
- The true residual is now used to evaluate the convergence of an iterative solution with the CBFM method.
- Memory usage during a solution is now shown in the log panel.

Resolved Issues

- Added an error message to the newFASANT GTD-PO and Ultrasound modules indicating when some mesh-derived information is not up to date for the current solution and re-meshing is required.
- The range of the l parameter in the BiCGStab(l) solver assigned by the user has been fixed.

Altair Feko 2021.0.3 is available with new features, corrections and improvements. This version (2021.0.3) is a patch release that should be applied to an existing 2021 installation.

This chapter covers the following:

- [Feko 2021.0.3 Release Notes](#) (p. 230)
- [WinProp 2021.0.3 Release Notes](#) (p. 232)

Feko is a powerful and comprehensive 3D simulation package intended for the analysis of a wide range of electromagnetic radiation and scattering problems. Applications include antenna design, antenna placement, microstrip antennas and circuits, dielectric media, scattering analysis, electromagnetic compatibility studies including cable harness modelling and many more.

WinProp is the most complete suite of tools in the domain of wireless propagation and radio network planning. With applications ranging from satellite to terrestrial, from rural via urban to indoor radio links, WinProp's innovative wave propagation models combine accuracy with short computation times.

newFASANT complements Altair's high frequency electromagnetic software tool (Altair Feko) for general 3D EM field calculations, including, among others, special design tools tailored for specific applications like complex radomes including FSS, automated design of reflectarrays and ultra-conformed reflector antennas, analysis of Doppler effects, ultrasound systems including automotive or complex RCS, and antenna placement problems. Advanced solver technologies like the MoM combined with the characteristic basis functions (CBFS), PO/GO/PTD, GTD/PO and MLFMM parallelised through MPI/OpenMP, being some of them especially efficient for the analysis of electrically very large problems.

Feko 2021.0.3 Release Notes

The most notable extensions and improvements to Feko are listed by component.

CADFEKO

Resolved Issues

- Fixed a crash when saving a model containing a cable schematic with unconnected components in Feko 2021.
- When using the HyperStudy-Feko link CADFEKO variables may not have correctly updated if the label of the variable was changed in HyperStudy. This has been fixed so that variable label renames in HyperStudy are supported.
- Fixed an issue where the mesh size histogram (**Mesh information** dialog) was shifted by one bin. It could appear as if the whole histogram plot is shifted, since the left-most bar was drawn as a vertical line in some cases.
- Improved the quadcopter platform model included in the component library to avoid mesh errors when solving at certain frequencies.
- Fixed an error in the Generate antenna array applicationmacro which resulted in incorrect port excitations when importing excitation data from a `.csv` file for a custom array with more than one port.

POSTFEKO

Resolved Issues

- Fixed a regression in POSTFEKO 2021 where, after adding wire currents to a 3D view, it was not possible to turn off the currents display either by toggling the visibility or removing it from the results panel.
- Resolved the issue that Touchstone imports were case sensitive.
- Resolved a problem where opening models in non-interactive mode caused the screen to flash with the POSTFEKO GUI opening and quickly closing again.

Solver

Resolved Issues

- Resolved an issue that resulted in an error during per-unit length parameter calculations of some cables with thin elongated mesh elements in their cross-section.
- When using periodic boundary conditions (PBC) with geometry that touches the infinite boundary, the incorrect detection of an open SEP region (error 38878) will be avoided.

- When using relaxed cable load restrictions, a warning (rather than an error) will be given when signals are connected across a shield. For the combined MoM/MTL cable solution an error will still be given if the connection is across the outermost shield.
- Fixed an out-of-bounds segmentation violation that may have occurred during the search for junction triangles when triangles attach to both sides top and bottom of an infinite metallic plate.
- Resolved an issue that resulted in an error when determining the reference signal during the solution of a model with cables. Consistency checks for the existence of such a signal were improved.

Shared Interface Changes

Resolved Issues

- Resolved an issue where a model or session file that was opened and closed again could not be deleted from disk while the application remained open.

WinProp 2021.0.3 Release Notes

The most notable extensions and improvements to WinProp are listed by component.

ProMan

Features

- Added support for geodetic to UTM coordinate conversion during trajectory import.
- Headers of `.str` ASCII output files are now aligned with corresponding values, so such files can be more easily imported into Excel.

Resolved Issues

- Fixed a license bug that occurred when solving an SRT project, with more transmitters than the maximum number of threads supported by the license, using the maximum supported number of threads.
- Increased the maximum number of samples along a trajectory to one million.
- Resolved an issue with IRT pre-processing when multiple buildings share the same wall.
- Corrected the deterministic two-ray model (in the superposition of the direct and the ground-reflected ray at the observation point) to include the 180 degrees phase shift of the ground-reflected ray at the reflection point.
- Resolved an issue with importing a `.ffp` file that has multiple dots in the file name.

Application Programming Interface

Features

- Added support for OFDM network planning in point mode with the WinProp API.

Resolved Issues

- Fixed a bug that deleted the disabled sites and antennas of a project if it was simulated with the WinPropCLI.
- Fixed a crash in case of `PATTERN_MODE_2X2D` for the antenna pattern.
- Added support for `.tdv` databases in indoor scenarios.
- Fixed a bug that resulted in a linking error in the database conversion API sample project.

Altair Feko 2021.0.2 is available with new features, corrections and improvements. This version (2021.0.2) is a patch release that should be applied to an existing 2021 installation.

This chapter covers the following:

- [Feko 2021.0.2 Release Notes](#) (p. 234)
- [WinProp 2021.0.2 Release Notes](#) (p. 237)
- [newFASANT 2021.0.2 Release Notes](#) (p. 239)

Feko is a powerful and comprehensive 3D simulation package intended for the analysis of a wide range of electromagnetic radiation and scattering problems. Applications include antenna design, antenna placement, microstrip antennas and circuits, dielectric media, scattering analysis, electromagnetic compatibility studies including cable harness modelling and many more.

WinProp is the most complete suite of tools in the domain of wireless propagation and radio network planning. With applications ranging from satellite to terrestrial, from rural via urban to indoor radio links, WinProp's innovative wave propagation models combine accuracy with short computation times.

newFASANT complements Altair's high frequency electromagnetic software tool (Altair Feko) for general 3D EM field calculations, including, among others, special design tools tailored for specific applications like complex radomes including FSS, automated design of reflectarrays and ultra-conformed reflector antennas, analysis of Doppler effects, ultrasound systems including automotive or complex RCS, and antenna placement problems. Advanced solver technologies like the MoM combined with the characteristic basis functions (CBFS), PO/GO/PTD, GTD/PO and MLFMM parallelised through MPI/OpenMP, being some of them especially efficient for the analysis of electrically very large problems.

Feko 2021.0.2 Release Notes

The most notable extensions and improvements to Feko are listed by component.

CADFEKO

Feature

- Added support for applying characterised surfaces to model mesh faces.

Resolved Issues

- Resolved an issue where the application could close with a critical error when adding a schematic view. This could happen for views where extremely small elements are drawn when the view is zoomed to extents.
- Avoided an assertion failing with the message `Assertion failed: nodes.count() == 1` when connecting cable schematic elements across cable shields. An error is printed to the `.pre` file instead.
- Resolved an issue that could cause an assertion failing with the message `Assertion failed: numRows > 1` when modifying a ground plane after deleting media.
- Resolved an issue where importing a Parasolid file could result in an assertion failing with the message `common_ModelLabelPolicy.cpp (84): Assertion failed: convertOK`. This problem was encountered when importing models containing parts with numerically-suffixed labels, for example `part2_100`, where the suffix was greater than 2147483647.
- Resolved a problem that caused the **Solution method** setting on the **Region properties** dialog to show an indeterminate state when the regions are selected by using the **Select all in part** functionality.
- Increased the maximum length and width of the geometry that can be generated using the create rough sea surface application macro script to 1000 m.

EDITFEKO

Resolved Issue

- Fixed a problem with the SK card that was introduced in Feko 2021. Opening the card panel when the card was populated with a characterised surface definition triggered an error that the card contains unknown field values.

POSTFEKO

Resolved Issues

- Improved the performance of plotting many results in a 3D view.

- Reworked the 3D view legend drop-down menus to show a **More...** option when the active 3D view contains more results than will fit on the menu. Before, the menu would cut off, not allowing the user to select from all results on the view when setting the legend.
- Fixed a regression in POSTFEKO 2021 where, after adding surface currents to a 3D view, it was not possible to turn off the currents display either by toggling the visibility or removing it from the results panel.
- Fixed an issue where the selected **Graphics driver** setting on the **Rendering options** dialog was not persisted across instances of POSTFEKO.
- An issue exists in POSTFEKO where plotting results in the 3D view with legends present could result in a crash when clicking in the 3D view. The crash occurs when the views are resized to be small and may be encountered when tiling many views. When encountering this crash, select a different **Graphics driver** on the **Rendering options** dialog. Note that the driver setting will only be applied to new 3D views that are created or opened after the setting is applied.
- Resolved the following issues with far field export to `.ffe` file:
 - U and V were sometimes written out the column headers instead of Theta and Phi.
 - Corrected the number of samples when the **Result type** is RCS.
- Changed the capitalisation of the **File type** field in `.ffe`, `.efe`, `.hfe` and `.tr` file exports to strictly adhere to the described format.
- Fixed the concurrent export of multiple results to write the results to separate files, using the specified filename with the request label as suffix.
- Resolved a problem with the normalisation of power traces in dB on Cartesian graphs. Normalisation was applied incorrectly when using the ribbon controls.
- Resolved a problem with the calculation of transmission line length and incorrect values for transmission line length being displayed in the details tree.
- Resolved an issue with the parameter sweep script where an error was triggered in Feko 2021 when selecting to run POSTFEKO from the batch run window.

Solver

Feature

- The wire segment part of the geometry processing phase has been parallelised, resulting in significant time savings for models with many wire segments.

Resolved Issues

- Accelerated the windscreen initialisation phase of parallel solution. Speed-up factors of 300x, compared to a previous version of Feko, are achievable depending on the size of the model and the number of parallel processes.
- Improved the accuracy of models, consisting of dielectrics with a large dielectric constant, simulated with periodic boundary conditions.
- Fixed a bug that led to incorrect results, due to compiler optimisations on Windows, when using the spherical harmonics based MLFMM solution.

- Corrected inaccuracies when solving larger models with dielectric media junctions requiring out-of-core memory. This problem was introduced with performance improvements made to Feko 2019.3.

Shared Interface Changes

Feature

- Added a transmission line calculator to the application macro library. This calculator can be used to calculate physical dimensions and electrical characteristics of microstrip, stripline and coplanar waveguide transmission lines.

Resolved Issues

- Fixed a regression that got introduced in Feko 2021 that caused a 3D mouse to be completely unresponsive.
- Added message feedback to the **Graphics driver** setting similar to the feedback that is given when modifying other rendering settings that require a new view to be opened before taking effect.

Support Components

Feature

- Added the supported KBL version (v2.3) to Section 2.20.3 Harness Description List (KBL) Specification in the Feko User Guide.

Resolved Issue

- Fixed a bug when fitting the response generated by adaptive frequency sampling of a model with a simulated bandwidth ratio of more than 100 (ADAPTFEKO).

WinProp 2021.0.2 Release Notes

The most notable extensions and improvements to WinProp are listed by component.

General

Feature

- Improved the display of fonts and icons on modern high-definition monitors.

Resolved Issue

- Fixed a bug that resulted in the inability to display a project in 3D view over a remote desktop connection.

ProMan

Features

- Added support for scattering consideration from topography/clutter triangles in predictions using the rural ray tracing model.
- Implemented multi-selection for prediction points, for example, to delete many in one operation if desired.
- Added support to display background images mapped to topography in 3D view.
- Improved the description of the array azimuth angle in the mobile station settings dialog.
- The minimum power azimuth spectrum resolution is now 0.25 degrees. Additionally power azimuth spectrum results are now in line with the ray angles for directions of departure/arrival.
- Improved the functionality to import a transmitter from `.CSV` such that all the quantities can be selected at once.

Resolved Issues

- Fixed 3D view display problems on a secondary monitor.
- The location offset for omnidirectional antenna elements can now be defined when setting up the mobile station.
- The option to select a **Components Catalogue** is disabled for projects without network planning.
- Fixed a bug that caused a crash when components are connected to a combiner.
- Fixed a bug that resulted in incorrect Doppler shift calculations when the velocity vector, defined in WallMan, is not normalised. This vector is henceforth internally normalised prior to Doppler shift calculations.
- Fixed a crash that could occur when the dominant path model is used in combination with a non-horizontal prediction plane.
- For rural projects using the parabolic equation method, all pixels are now computed.

- Fixed a bug that prevented selecting desired number of Rx elements in the mobile station settings dialog.
- Removed **Traffic Class Specification** from the drop-down list available under the **Data** menu option. Traffic class specification can be done under the **Traffic** tab of the project parameter settings.
- The progress window is now left open if the option **Leave window always open when completed** is selected during network planning.
- Fixed a bug that prevented display of the RunMS sub-channel results in the result tree when the **Save prediction results of each antenna/cell in individual sub-directory** option is selected under **Global settings**.
- Fixed a bug that caused the total phase of the field reported in **Channel Matrices per Point** to differ from the correct phase reported in the `.str` file.
- Fixed a bug that resulted in a crash when all components, such as amplifiers or combiners, are simultaneously deleted from the **Components** tab of the project's settings.

WallMan

Resolved Issues

- Fixed 3D view display problems on a secondary monitor.
- Fixed a bug that prevented saving a database in WallMan, after adding clutter classes.

CompoMan

Resolved Issues

- Fixed a bug that caused a crash when a user-defined category was edited or deleted.
- Fixed a bug that caused a crash when a user-defined field was added.

Application Programming Interface

Feature

- Added support for network planning using OFDM broadcasting in the WinProp API.

newFASANT 2021.0.2 Release Notes

The most notable extensions and improvements to newFASANT are listed by component.

GUI

Feature

- Added a table to show/edit directions (theta/phi angles) to be used by the newFASANT PO module. This ability allows for RCS computations in an arbitrary set of directions. This information can be imported from and exported to a text file.

Solver

Resolved Issues

- Added an error message to the newFASANT GTD module indicating when some mesh-derived information is not up to date for the current solution and re-meshing is required.
- Improved the parallelisation scheme in the GTD module of newFASANT for cases where multiple processors are available and there is only one observation point.
- Extended the information written by the newFASANT GTD module to the `projecth.ray` file to include the coordinates of the ray interaction points.

Altair Feko 2021.0.1 is available with new features, corrections and improvements. This version (2021.0.1) is a patch release that should be applied to an existing 2021 installation.

This chapter covers the following:

- [Feko 2021.0.1 Release Notes](#) (p. 241)
- [WinProp 2021.0.1 Release Notes](#) (p. 243)
- [newFASANT 2021.0.1 Release Notes](#) (p. 245)

Feko is a powerful and comprehensive 3D simulation package intended for the analysis of a wide range of electromagnetic radiation and scattering problems. Applications include antenna design, antenna placement, microstrip antennas and circuits, dielectric media, scattering analysis, electromagnetic compatibility studies including cable harness modelling and many more.

WinProp is the most complete suite of tools in the domain of wireless propagation and radio network planning. With applications ranging from satellite to terrestrial, from rural via urban to indoor radio links, WinProp's innovative wave propagation models combine accuracy with short computation times.

newFASANT complements Altair's high frequency electromagnetic software tool (Altair Feko) for general 3D EM field calculations, including, among others, special design tools tailored for specific applications like complex radomes including FSS, automated design of reflectarrays and ultra-conformed reflector antennas, analysis of Doppler effects, ultrasound systems including automotive or complex RCS, and antenna placement problems. Advanced solver technologies like the MoM combined with the characteristic basis functions (CBFS), PO/GO/PTD, GTD/PO and MLFMM parallelised through MPI/OpenMP, being some of them especially efficient for the analysis of electrically very large problems.

Feko 2021.0.1 Release Notes

The most notable extensions and improvements to Feko are listed by component.

CADFEKO

Features

- Added shunt-fed monopole and dipole antennas to the component library.
- Added a version selector for CATIA V5 exports.

Resolved Issues

- Resolved a problem where the edges of tetrahedra in meshes of transformed geometry parts did not align with FEM line ports.
- Fixed an issue where running CADFEKO_BATCH on models containing cable ports caused an assertion to fail.
- Resolved an issue with **Specified points** near field requests using workplanes. The workplane orientation was incorrectly applied.
- Improved the progress feedback given during export to CATIA V5 format.

POSTFEKO

Feature

- Added support for the visualisation of the impressed solution coefficient source.

Solver

Features

- Improved FEM matrix and metallic loss calculation for FEM models which include lossy metallic faces.
- Improved the accuracy of S-parameter calculations of cable models.
- When analysing radiated emissions using a `.rei` file generated by the PolEx radiated emissions analysis tool for a PCB which includes dielectrics and ground planes, the radiated emissions calculated may be inaccurate. A two-step workflow using the new solution coefficient request and a new impressed solution coefficient source to achieve more accurate results is now supported. An application macro is available in CADFEKO to assist with this workflow.

Resolved Issues

- Fixed a bug that resulted in incorrect far field results, computed with the fast far field method, for an RL-GO model consisting of a multi-layer substrate.

- Fixed a bug that may have resulted in an exception during the calculation of near field matrix elements when solving a model with segments/wires using MLFMM.
- Fixed a bug that resulted in a segmentation violation during near field computations of a large model solved with MLFMM.
- Fixed a bug that may trigger a segmentation violation when multiple pins of a cable black box (network/circuit) are short circuited.
- Fixed an error that may have resulted in failure during mesh vertex processing for models including planar and curvilinear triangles.
- Fixed a bug that resulted in an internal error state when solving a planar Green's function model with near field requests in multiple configurations.
- An error message is now issued when an invalid TM mode is specified at a rectangular waveguide port.

WinProp 2021.0.1 Release Notes

The most notable extensions and improvements to WinProp are listed by component.

General

Features

- Corrected an example, C22 with TETRA, that failed during simulation.

ProMan

Features

- ProMan now accepts finer result resolutions than before. The minimum value is scenario dependent, for example, the minimum distance between evaluation points along trajectories is 1 mm.
- The field strength and phase values are written to the `.str` file with an accuracy of six decimal places.
- Added support for extended Hata model predictions over distances smaller than 0.1 km.
- A subset of buildings/objects to be considered during simulation can now be defined individually for each transmitter for indoor and urban scenarios in ProMan.
- The display height chosen by the user is now saved with the project (indoor or urban). When the project is reopened, the saved display height will be used instead of a global default height.

Resolved Issues

- The ground resolution is now used when considering scattering effects at topo triangles.
- Improved the accuracy of predictions with the Longley-Rice model.
- Fixed a crash in auto-calibration with the Motley-Keenan model.
- Resolved the issue that user-defined text could not be added to legends.

WallMan

Features

- Added support for choosing default building heights when converting an OpenStreetMap database to the WinProp urban format.

Resolved Issues

- Fixed a bug that led to a format error when an indoor database (`.idb`) is imported into an outdoor database (`.odb`).
- Marker points, saved in a database, can now be deleted in WallMan.

- Removed the building/wall type **Evaluation Area (Vector Mask)** since it's essentially a duplicate of other available wall types, namely **Graphical Wall** for indoor and **Virtual Building** for urban scenarios.

Application Programming Interface

Features

- A subset of buildings to be considered during simulation can now be defined for indoor and urban scenarios using the WinProp API.
- Added support to the API for network planning calculations in point mode.
- Added support for predictions with the parabolic equations model using the WinProp API.

newFASANT 2021.0.1 Release Notes

The most notable extensions and improvements to newFASANT are listed by component.

General

Feature

- Added support to read in directions (theta/phi angles) from a text file to the newFASANT PO module to allow for RCS computations in arbitrary directions.

GUI

Resolved Issue

- Corrected errors in the reflectarray feature of the newFASANT MOM module that may have resulted in the creation of incorrect reflectarray layouts and errors during simulation.

Solver

Resolved Issues

- Fixed a bug that resulted in some directions not being computed during a parallel bistatic RCS solution of a PO model.
- Fixed a bug that resulted in a simulation error when a trim operation is performed between two surfaces in the PO module.
- Fixed a bug that resulted in inaccurate results when solving a periodic cell element excited by a plane wave with oblique incidence.
- Fixed a bug that affects only certain observation points when the wedge diffraction is computed with the GTD or GTD-PO module.
- Improved the accuracy of the RCS results in some cases when using the PO solver (newFASANT GTD-PO module)

Altair Feko 2021 is available with a long list of new features, corrections and improvements. Altair Feko 2021 is a major release. It can be installed alongside other instances of Altair Feko.

This chapter covers the following:

- [Highlights of the 2021 Release](#) (p. 247)
- [Feko 2021 Release Notes](#) (p. 250)
- [WinProp 2021 Release Notes](#) (p. 253)
- [newFASANT 2021 Release Notes](#) (p. 255)

Feko is a powerful and comprehensive 3D simulation package intended for the analysis of a wide range of electromagnetic radiation and scattering problems. Applications include antenna design, antenna placement, microstrip antennas and circuits, dielectric media, scattering analysis, electromagnetic compatibility studies including cable harness modelling and many more.

WinProp is the most complete suite of tools in the domain of wireless propagation and radio network planning. With applications ranging from satellite to terrestrial, from rural via urban to indoor radio links, WinProp's innovative wave propagation models combine accuracy with short computation times.

newFASANT complements Altair's high frequency electromagnetic software tool (Altair Feko) for general 3D EM field calculations, including, among others, special design tools tailored for specific applications like complex radomes including FSS, automated design of reflectarrays and ultra-conformed reflector antennas, analysis of Doppler effects, ultrasound systems including automotive or complex RCS, and antenna placement problems. Advanced solver technologies like the MoM combined with the characteristic basis functions (CBFS), PO/GO/PTD, GTD/PO and MLFMM parallelised through MPI/OpenMP, being some of them especially efficient for the analysis of electrically very large problems.

Highlights of the 2021 Release

The most notable extensions and improvements to Feko in the 2021 release.

Salient Features in Feko

- The application macro library in CADFEKO and POSTFEKO is extended with more scripts that are grouped by functionality.

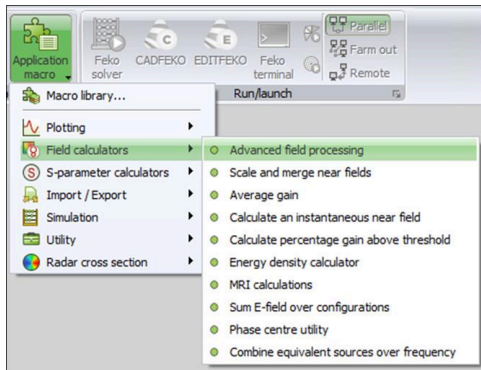

Figure 52: The application macro library menu in POSTFEKO.

- Enhanced surface modelling options:
 - Thick coatings for modelling RAM materials are supported for the MLFMM.
 - The effect of surface roughness of metals (for example, due to etching processes) can be included.
 - SAR can be calculated based on surface impedance. This provides a very fast calculation approach.

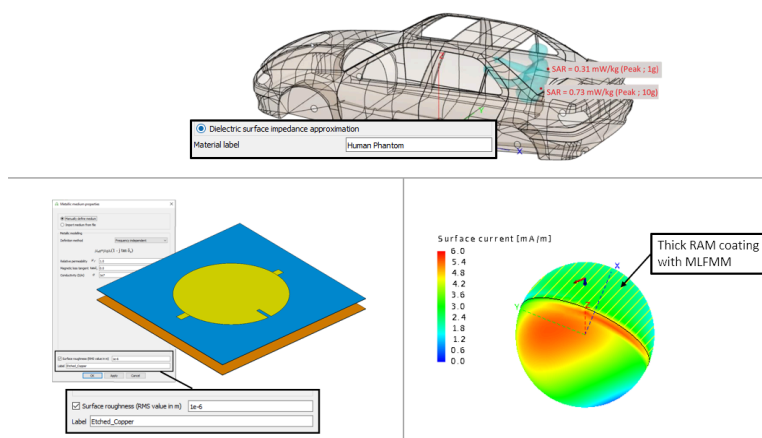

Figure 53: New surface modelling options enabling fast SAR calculation, consideration of metal surface roughness effects and simulation of thick, high-loss dielectric coatings for RAM applications.

- New antennas are available in the component library.

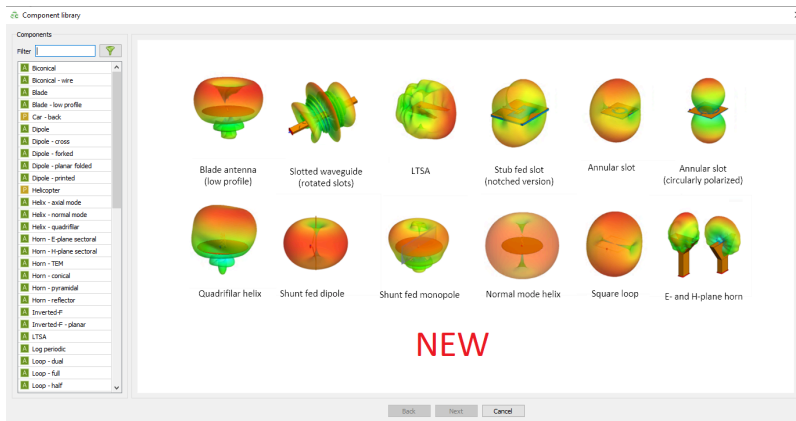

Figure 54: A selection of new antennas in the CADFEKO component library.

- Cable modelling extensions:
 - S-parameter results for cable ports can be requested in CADFEKO.
 - Combined MoM/MTL cable paths can now be connected in the same harness.
 - Unshielded cable cross-sections are supported in the combined MoM/MTL cable solution.

Salient Features in WinProp

- Added support in ProMan to plot radar results as a heat map, with range and relative velocity along the axes and the signal strengths as colours.

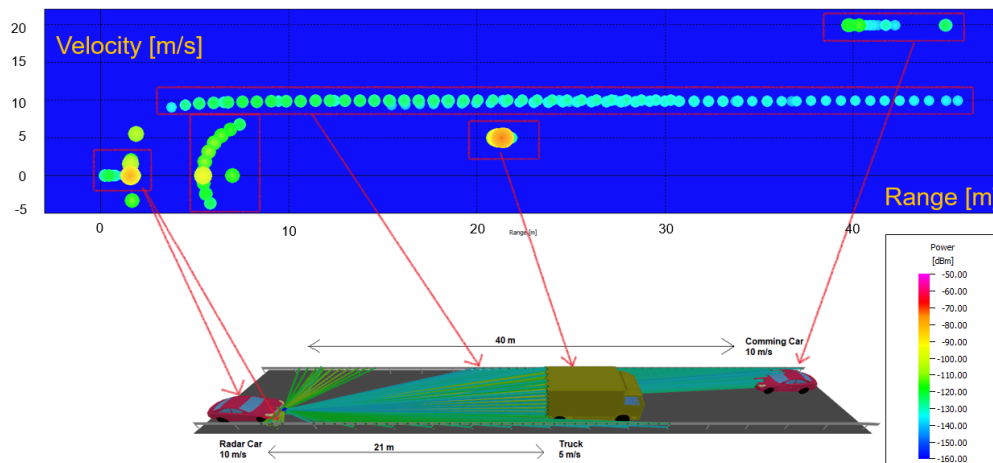

Figure 55: An example of a heat map for automotive radar.

- Added support in ProMan and WinProp API to support network planning time-variant scenarios.
- Improved the dominant path model (DPM) using extensive customer measurements and Altair HyperStudy. The mean difference with measurements is now only 2 dB and standard deviation is 6 dB.
- Incorporated GDA libraries for geometry conversion of indoor and urban databases. This allows for the conversion of more formats, such as .gml.

Salient Features in newFASANT

- The newFASANT User Guide is now available as a unified guide that can be accessed from the Launcher utility in PDF or HTML format.

Feko 2021 Release Notes

The most notable extensions and improvements to Feko are listed by component.

CADFEKO

Features

- Introduced a new cable port type to support multiport S-parameter requests for cable modelling.
- Face coatings are extended to support thick, single-layer coatings for modelling radiation-absorbent materials (RAM).
- Added support for specifying surface roughness (root mean square value in metre) when defining a metallic medium.
- Extended near field requests to support a **Specified points** definition method that allows defining the field points as a list of arbitrary points. The points can be entered manually, can be added using point entry or can be imported from a file.
- Added support for zooming to selected ports on the active schematic view (cable harness schematic or network schematic). Select one or more ports in the model tree and from the right-click context menu select **Zoom to selection**.
- Upgraded the CAD import library to provide access to the latest CAD formats and to benefit from the latest bug fixes and performance improvements.
- Added support for importing CATIA V5 files on Linux systems.

Resolved Issues

- Resolved a defect where deleting multiple ports would result in an assertion failure with the message `Assertion failed: pPortNode` when undoing the deletion.
- Resolved a defect where the position of network schematic symbols (ports, general networks and transmission lines) would not update through undo and redo actions.

EDITFEKO

Features

- Added the **AM - Define a solution coefficient source** card. This card adds support for adding an impressed solution coefficient source to a model.
- Added a new **MD - Options for model decomposition** card. This general control card is used to manage the export of model and solution coefficients to `.sol` file.
- Extended the SK card^[2] with the options to:
 - specify the surface roughness for metallic triangles.

2. The SK card is used for applying the skin effect and other surface properties.

- select the dielectric surface impedance approximation for a dielectric region.

POSTFEKO

Features

- Increased the `.fek` file version to 177 to accommodate new features.
- Upgraded the library that is used for the reading and writing of `.mat` files (using the API functions in the `MatIO` namespace).
- Added support to Cartesian and surface graphs for plotting values in reversed order along the axes. Enable the **Reversed order (horizontal)** option to change the direction of the horizontal axis so that axis values increase from right to left. Enable the **Reversed order (vertical)** option to change the direction of the vertical axis so that axis values increase from top to bottom.

Solver

Features

- Added support for unshielded cable cross-sections in the combined MoM/MTL cable solution.
- Added support for an MLFMM solution of models where thick dielectric coatings are applied to faces.
- Improved the time efficiency of the calculation of right-hand side vector and matrix solution phases of parallel computations for the ACA solver.
- Improved the accuracy of RL-GO simulations by considering the effects of phase variations at interaction points.
- Implemented dielectric surface impedance approximation for lossy dielectric objects. This feature may be used to compute SAR values for any homogeneous phantom.
- Added support for modelling effects of metallic surface roughness.
- Upgrade to MUMPS version 5.3.3consortium.
- The assembled ACA matrix and its LU decomposition can now be exported as `.acm` and `.acl` files.
- A warning is now issued when current continuity is not satisfied at the end points of impressed currents. Possible point charges at these terminations are not considered.
- Updated the CUDA Runtime API to version 10.2.
- Surface currents, on selected faces in a model, can now be exported and used as sources in another model.
- Accelerated the geometry processing phase of the solution of FEM models. Speed-up factors of more than 5x are achievable, depending on the number of tetrahedra in the model.
- Significantly accelerated SAR calculation. Speed-up factors of 10x are attainable, depending on the model.
- Improved the memory efficiency of MLFMM solutions regarding the Fourier coefficients storage.

Resolved Issues

- Fixed a bug that resulted in memory leaks in the default circuit solver that is used when evaluating models consisting of cables.
- Fixed a bug when considering field contributions at a receiving antenna in a model that includes radiating sources and a planar multi-layer substrate.
- Introduced an error message when attempting to use periodic boundary conditions with decoupled MoM/FEM solution.
- Improved validation to provide an error message when dielectric/magnetic coating is used with MoM/MLFMM and normal vectors are not pointing towards the source.

Shared Interface Changes

Features

- Upgraded the graphical user interface to use Qt 5.15.
- Added numerous application macros (automation scripts) to the CADFEKO and POSTFEKO application macro libraries. These macros supplement existing functionality in the applications by offering utilities that simplify certain repetitive tasks, like plotting results consistently across various graphs, and calculators for advanced result post-processing.
- Upgraded OpenSSL to version 1.1.1g.

Resolved Issue

- Resolved a problem where the API `Interpolator` object returned incorrect results for some resampled independent axis values.

Support Components

Features

- Extended PREFEKO to import model solution coefficients source `.sol` file.
- An updated and unified newFASANT User Guide is now available in PDF and HTML. It can be accessed from the Feko Launcher.
- Added an Example 5 (Network Planning) to the WinProp Getting Started Guide that presents the steps on how to complete a network planning simulation based on a predefined air interface (`.wst`) file.
- Added the Feko application macros chapter in the Feko user guide. The chapter contains information on the application macros available in CADFEKO and POSTFEKO.
- Corrected Table 50 in Section 5.3.3 Solution Methods per Application in the Feko User Guide to show that RL-GO is ideally suited for radar cross-section (RCS) calculations.

WinProp 2021 Release Notes

The most notable extensions and improvements to WinProp are listed by component.

General

Feature

- A bitmap, imported in a TuMan XY-view, is now also written to the exported binary file and can thus be used for further processing in WallMan or ProMan.

Resolved Issue

- Added the automotive-radar example (Example D.3) to the WinProp Example Guide that was missing in the 2020 release.

ProMan

Features

- Added support for selecting the **Individual location offset** for each element option for transmitting antenna in the propagation post-processing.
- Added the option to plot radar results as a heat map, with range and relative velocity along the axes and the signal strengths as colors. This gives intuitive insight into how a traffic situation with obstacles and vehicles is perceived by the radar.
- Angular and delay spreads can now be selected as output quantities in simulations with the rural ray tracing model.
- Added support for network planning simulations in time-variant scenarios.
- Added an option to generate channel profiles in Keysight PROPSIM format with absolute delays.
- Added ability to select a subset of transmitters for network planning simulations.
- Improved the accuracy of the dominant path model with the help of extensive customer measurements and Altair HyperStudy. For example, the calculation of urban "wave guiding" through streets was improved. Also, a couple of bugs that could lead to "artifacts" in result plots were fixed.
- Diversity combining results can now be computed during post-processing with RunMS.

Resolved Issues

- The selected discretization of leaky feeder cables is now applied when computing propagation results.
- Corrected a small difference in the exact prediction areas used for the dominant path model in the GUI and the API.

WallMan

Features

- Added support for converting newer versions of .dwg and .dxf files to urban/indoor databases.
- Incorporated the GDA Libraries for geometry conversion of indoor and urban databases. This improves robustness and enables conversion of more formats, such as .gml.

Resolved Issues

- The dynamic behaviour, including translation and rotation, of moving objects in a time-variant database can now be imported/export from/to a file.

Application Programming Interface

Features

- Added support for .dxf / .dwg database conversion using the WinProp API on Linux.
- Added the option of polarization-dependent interference to the API.

Resolved Issue

- Removed GDAL functionality from Engine.dll. All database conversion functionality is moved to EngineConvert.dll.

newFASANT 2021 Release Notes

The most notable extensions and improvements to newFASANT are listed by component.

Solver

Features

- Added a mechanism to allow simulations, with the MoM and MONCROS modules, to proceed to the next phase with the lowest obtained residuum, if a user halts the run during the iterative solution of linear equations.
- The number of MPI processes is reduced when it is greater than the number of MLFMM regions. A warning is displayed for the user.
- Improved the memory efficiency of Hybrid (MPI +OpenMP) solver for macro basis function (CBFs).
- The **Speed Up** feature in the MONCROS module is extended to bistatic RCS computations.
- Added a mechanism for interactively activating/deactivating the SAI preconditioner in the solution process.

Resolved Issues

- Fixed a bug found on the frequency information written in the results_cmpfreq* files and modified the format for writing the frequency and scattered field with more precision.
- Improved the accuracy of the solution obtained using the SAI preconditioner.

Altair Feko 2020.1.2 is available with new features, corrections and improvements. This version (2020.1.2) is a patch release that should be applied to an existing 2020 installation.

This chapter covers the following:

- [Feko 2020.1.2 Release Notes](#) (p. 257)
- [WinProp 2020.1.2 Release Notes](#) (p. 259)
- [newFASANT 2020.1.2 Release Notes](#) (p. 262)

Feko is a powerful and comprehensive 3D simulation package intended for the analysis of a wide range of electromagnetic radiation and scattering problems. Applications include antenna design, antenna placement, microstrip antennas and circuits, dielectric media, scattering analysis, electromagnetic compatibility studies including cable harness modelling and many more.

WinProp is the most complete suite of tools in the domain of wireless propagation and radio network planning. With applications ranging from satellite to terrestrial, from rural via urban to indoor radio links, WinProp's innovative wave propagation models combine accuracy with short computation times.

newFASANT complements Altair's high frequency electromagnetic software tool (Altair Feko) for general 3D EM field calculations, including, among others, special design tools tailored for specific applications like complex radomes including FSS, automated design of reflectarrays and ultra-conformed reflector antennas, analysis of Doppler effects, ultrasound systems including automotive or complex RCS, and antenna placement problems. Advanced solver technologies like the MoM combined with the characteristic basis functions (CBFS), PO/GO/PTD, GTD/PO and MLFMM parallelised through MPI/OpenMP, being some of them especially efficient for the analysis of electrically very large problems.

Feko 2020.1.2 Release Notes

The most notable extensions and improvements to Feko are listed by component.

CADFEKO

Features

- Added thirteen new antennas to the component library, including a quadrifilar helix, E-plane and H-plane horns as well as notched and circularly polarised slot antennas.
- Extended export to I-DEAS universal format (.unv file) when exporting media information:
 - to take into account face normals (face front/back medium) when exporting media information;
 - to export layered dielectric face media.

Resolved Issues

- Resolved a problem affecting model mesh parts where coatings and layered dielectric properties were not included in the simulation. The relevant CO and SK cards were not written out to the .pre file for mesh parts.
- Resolved an issue where faces with layered anisotropic dielectric properties were not correctly included in the model for simulation. Existing models should be meshed and saved for the properties to be applied.
- Resolved a defect where .pre file entries for loads or voltage sources were not always written out correctly for multi-configuration models where entities were the same between configurations. This could have resulted in missing data in POSTFEKO.

POSTFEKO

Feature

- Extended unit support when importing results from HDF5 files in the DRE format. The degree, Ohm and micro symbols are now supported for these imports.

Resolved Issues

- Resolved an issue with the parameter sweep script which resulted in a frequency point mismatch error when sweeping a model with only a single frequency.
- Resolved an issue where `GetDataSet` could return too many untracked characteristic modes. The data that got returned for the additional modes were meaningless and the values could be different when running `GetDataSet` multiple times.
- Added support for W/Hz unit conversions. This resolves an assertion that failed when enabling trace maths, using the custom unit of W/Hz and changing the vertical axis unit.
- Resolved an assertion that fails when using the multiplication operator (*) in unit expressions.

Solver

Resolved Issues

- Fixed a bug that resulted in large memory usage when solving a model excited by a plane wave looping over multiple angles of incidence.
- Fixed a bug that led to an internal error during the cable cross-section meshing phase for a pre-defined coaxial cable that is treated as a child cross-section within a larger bundle.
- Fixed a bug that resulted in longer near field computation times.
- Fix a bug that suppressed realised gain export in far field result data for models containing passive sources, for example passive waveguide ports, in addition to a single active port-based source.

WinProp 2020.1.2 Release Notes

The most notable extensions and improvements to WinProp are listed by component.

ProMan

Features

- The data rate and throughput are now computed based on the MIMO condition number for MIMO network planning projects simulated using ray tracing models.
- Accelerated predictions with IRT in indoor scenarios.
- Databases pre-processed in area mode can now also be used for point mode predictions in ProMan.
- Reduced memory and storage requirements for pre-processing and simulating a project with a large database with many buildings at the same height.
- Improved the speed of IRT pre-processing for urban projects with large databases.
- Implemented the ability to compare results that were computed using different databases. This can be useful when comparing results for databases that were pre-processed using different settings. A warning will be given when the databases are not identical.
- Measurements assigned to a transmitter are now accessible in the results tree for visualisation.

Resolved Issues

- Angular spread ASCII results from RunMS were always showing the same value. This is now corrected.
- Rays of MIMO results computed in RunMS can now be displayed in ProMan.
- Fixed a bug that resulted in the incorrect consideration of horizontal plates during the line of sight analysis phase of a prediction.
- Exported `.kml` files are now placed in the correct location, regardless of zoom level, when viewed in Google Earth.
- Fix a bug that resulted in wrong LOS results for all but the last time step in a time-varying project.
- Fixed a difference in computation settings when a ProMan project is opened from the GUI versus by double-clicking the project file. Now both ways of opening a project lead to the same settings and results.
- Fixed a bug in indoor IRT. It used the material of the main wall for transmission through a sub-division such as a window or a door.
- Fixed a bug that prevented the display of buildings and results in a particular case. This was for urban scenarios that were pre-processed in point mode, together with results computed at absolute height. Added a **Top View** display option to show all buildings regardless of prediction height.
- Fixed a bug that occurred when considering scattering effects from topography in a model solved with the SRT propagation model.
- Fixed a bug during line-of-sight determination of indoor projects with topography, solved with the dominant path model.

- Fixed a bug where an inaccurate absolute transmitter height might be written to a result file for a transmitter on top of a building that is located on a slope.
- Fixed a bug that prevented adjustment of the display height in an urban scenario.
- Resolved an issue for the vertical plane models in urban scenarios (Knife-edge diffraction, COST231 and ITU-1411) where in seldom cases the computed ray was propagating through buildings.

WallMan

Features

- Removed the limit on the number of corners of a building for IRT pre-processing. The limit used to be 255.
- Improved the speed of IRT pre-processing for urban projects with large databases.

Resolved Issues

- Improved the adjustment of imported vegetation polygons to topography in urban scenarios. The vegetation will follow the topography more naturally, resulting in more accurate consideration of losses within vegetation.
- Diffraction effects from vertical wedges of horizontal plates are now considered during predictions with the urban IRT model.
- Fixed a bug that resulted in the 3D view not being available when a bitmap is displayed in 2D view with an urban or indoor database.
- Fixed a bug in the conversion from OpenStreetMap that resulted in horizontal non-building objects being assigned inaccurate thicknesses.

Application Programming Interface

Features

- Added support for coherent superposition in projects simulated using the deterministic two ray or urban IRT models with WinPropCLI.
- Binary result files can now be converted to ASCII files with WinPropCLI.
- Added support for parallel indoor database IRT pre-processing using the API or WinPropCLI on Linux.
- The version number of WinPropCLI is now printed to standard output at the beginning of every simulation.
- Included atmospheric losses in the API.

Resolved Issues

- Added RunMS support for time-variant scenarios with the API.
- Updated the C# example of the WinProp API to reflect recent modifications in the API.

- Improved the parallel efficiency when a project with many transmitters is simulated in parallel using WinPropCLI. Furthermore, added a function (`WinProp_Yield_NrOfThreads`) to the API that reserves a number of Altair units equivalent to the number of threads. This avoids repeated license checkout calls which might affect performance for parallel simulations across a large number of transmitters.

newFASANT 2020.1.2 Release Notes

The most notable extensions and improvements to newFASANT are listed by component.

GUI

Resolved Issue

- Removed the **Remesh** option under **Object Properties**. Remeshing is now enabled by default for UTD-based modules. For MoM/PO-based modules (MOM, MONCROS, PO, PERIODICAL) the **Remesh** option can be found under the **Meshing** tab.

Solver

Resolved Issue

- Fixed a bug which may have resulted in higher-order reflections not being found in some cases.

Altair Feko 2020.1.1 is available with new features, corrections and improvements. This version (2020.1.1) is a patch release that should be applied to an existing 2020 installation.

This chapter covers the following:

- [Feko 2020.1.1 Release Notes](#) (p. 264)
- [WinProp 2020.1.1 Release Notes](#) (p. 266)
- [newFASANT 2020.1.1 Release Notes](#) (p. 268)

Feko is a powerful and comprehensive 3D simulation package intended for the analysis of a wide range of electromagnetic radiation and scattering problems. Applications include antenna design, antenna placement, microstrip antennas and circuits, dielectric media, scattering analysis, electromagnetic compatibility studies including cable harness modelling and many more.

WinProp is the most complete suite of tools in the domain of wireless propagation and radio network planning. With applications ranging from satellite to terrestrial, from rural via urban to indoor radio links, WinProp's innovative wave propagation models combine accuracy with short computation times.

newFASANT complements Altair's high frequency electromagnetic software tool (Altair Feko) for general 3D EM field calculations, including, among others, special design tools tailored for specific applications like complex radomes including FSS, automated design of reflectarrays and ultra-conformed reflector antennas, analysis of Doppler effects, ultrasound systems including automotive or complex RCS, and antenna placement problems. Advanced solver technologies like the MoM combined with the characteristic basis functions (CBFS), PO/GO/PTD, GTD/PO and MLFMM parallelised through MPI/OpenMP, being some of them especially efficient for the analysis of electrically very large problems.

Feko 2020.1.1 Release Notes

The most notable extensions and improvements to Feko are listed by component.

CADFEKO

Feature

- Extended the Optenni Lab plugin with an option to include additional far field data for each active port.

Resolved Issues

- Resolved an issue with the **Inverted-F - planar** (PIFA) antenna in the component library. For the FEM variant of this antenna, the solution method of the airbox around the antenna was not set to the finite element method (FEM).
- Resolved an issue where the Optenni Lab plugin failed to connect the matching network if the model contains a characteristic mode configuration.
- Resolved an issue where the Optenni Lab plugin failed to detect the Optenni Lab installation. It now detects the Optenni Lab installation whether it is installed for all users or for the current user only.

POSTFEKO

Features

- POSTFEKO now supports the reading of Feko file format 8. The far field format is extended in version 8 to optionally include efficiency in the solution block header.
- Extended the parameter sweep script with additional error checking to indicate which parameter sweep run is faulty when it fails to combine results.

Resolved Issues

- Improved the error messages that get triggered when importing far fields from a `.ffe` file that does not adhere to the required format, for example, if the file lacks the required column headings or contains additional header blocks.
- Improved performance and reduced peak memory usage for the `FarField GetDataSet` method.

Solver

Features

- Metallic FEM tetrahedra are no longer considered during mesh element size checks since they do not contribute to the solution.

- Added support for antenna efficiency consideration when computing quantities associated with a receiving antenna.

Resolved Issues

- Fixed a bug that caused an allocation error during the geometry processing phase of a model with a large number of tetrahedra.
- Fixed a bug that caused a segmentation violation when too many samples were required in ADAPTFEKO.
- Improved the accuracy of RL-GO simulations that include diffraction effects.
- Fixed a bug that resulted in a crash upon program exit when solving some RL-GO models with the GPU on Linux.

Support Components

Features

- Antenna efficiency is now exported to the `.ffe` file.
- The version numbers for newFASANT and WinPropCLI are included on the Feko GUI update utility (**Installed versions** tab).
- Added a how-to in the Feko User Guide that presents the workflow on how to connect an antenna designed in CADFEKO to a mesh that was generated with Altair HyperMesh.

WinProp 2020.1.1 Release Notes

The most notable extensions and improvements to WinProp are listed by component.

General

Feature

- Significantly expanded the information in the User Guide on the inclusion of mobile-station antennas, including options for MIMO arrays.

ProMan

Features

- The MIMO condition number is now accessible for display from the result tree in ProMan.
- Updated the settings of the Mobile Station (RunMS options).
- Accelerated predictions using the SRT model. Speed-up factors of more than 2x are achievable when two or more interactions are considered in the model.
- Added support for the Extended Hata propagation model for frequencies from 2000 MHz up to 3000 MHz.
- A subset of buildings to be considered during simulation can now be defined for indoor and urban scenarios in ProMan.
- Added the capability to import also antenna efficiency from Feko antenna-pattern files (.ffe).

Resolved Issues

- Resolved an issue where, in Standard Ray Tracing, the direct line-of-sight ray could be computed with the path-loss exponent that had been defined for the non-line-of-sight rays.
- Fixed a bug that led to a crash during mobile station post-processing of a MIMO project when many rays per pixel were requested.
- Fixed a bug that led to an error in trajectory mode when the values for distance between evaluation points and for resolution are very small.
- Fixed an error in RunNET if the antenna gains of the MIMO antenna elements on the transmit side differ by more than 0.1 dB.
- Fixed a bug that prevented displaying the propagation results in 3D view for a project with many time steps.
- Fixed a bug which arose from ignoring the mismatch between UTM zones of databases of an urban model that includes topography data. An error message is now issued and the simulation is halted for such cases.
- Fixed a bug that resulted in a crash when cancelling a multi-threaded simulation of a project consisting of components such as transceivers.

- Fixed a bug which resulted in sub-divisions of walls of a time-variant object not moving along with the object when viewing results of different time steps in ProMan.
- The height correction factor is now considered in the Hata model for open and suburban areas.

WallMan

Feature

- Modified color assignment during geometry conversion. If an object was white in the original tool, it will not be white in WallMan, so that it will be visible against the white background.

Application Programming Interface

Features

- Added support for parallel simulations of projects with many transmitters with WinPropCLI.
- Added support for EMC/EMF calculations with the WinProp API.
- Added support for simulations of projects using the ITU-R P.1411 propagation model with the WinProp API.

Resolved Issues

- Fixed a bug that resulted in no propagation results being computed in an urban scenario when the **Indoor Prediction Only** option is selected.
- The transmission matrix is now written to the ASCII `.str` file when a project is simulated with the WinProp API
- The assignment of a custom value to predicted pixels with invalid results is now possible in point mode with the WinProp API.
- Fixed a bug that led to an error when setting the power backoff value for cell assignments during network planning with the WinProp API.
- Eliminated a few implementation differences between network planning via the GUI and via the API, such as number of digits behind a decimal point or a coordinate shift by a fraction of a pixel. Also ensured that the API will cover more scenarios.
- The licensing environment is now automatically set up when running WinPropCLI on Linux.

newFASANT 2020.1.1 Release Notes

The most notable extensions and improvements to newFASANT are listed by component.

GUI

Feature

- New definition of characteristic basis functions, which allows to reduce CBFM preprocessing time.

Resolved Issue

- Direct, scattered or total near field components can now be viewed as text file from the **Show Results** menu.

Solver

Features

- New definition of characteristic basis functions, which allows to reduce CBFM preprocessing time.
- Implemented an interpolation technique that estimates the solution when performing multi-frequency and/or multi-direction sweep analyses.
- Improved the memory usage of CBFM with OpenMP solver.

Resolved Issue

- Improvements have been made in the GTD-PO module to avoid possibly inaccurate results when computing monostatic RCS using the GTD method.

Altair Feko 2020.1 is available with new features, corrections and improvements. It can be applied as an upgrade to an existing 2020 installation, or it can be installed without first installing Altair Feko 2020.

This chapter covers the following:

- [Highlights of the 2020.1 Release](#) (p. 270)
- [Feko 2020.1 Release Notes](#) (p. 272)
- [WinProp 2020.1 Release Notes](#) (p. 274)
- [newFASANT 2020.1 Release Notes](#) (p. 276)

Feko is a powerful and comprehensive 3D simulation package intended for the analysis of a wide range of electromagnetic radiation and scattering problems. Applications include antenna design, antenna placement, microstrip antennas and circuits, dielectric media, scattering analysis, electromagnetic compatibility studies including cable harness modelling and many more.

WinProp is the most complete suite of tools in the domain of wireless propagation and radio network planning. With applications ranging from satellite to terrestrial, from rural via urban to indoor radio links, WinProp's innovative wave propagation models combine accuracy with short computation times.

newFASANT complements Altair's high frequency electromagnetic software tool (Altair Feko) for general 3D EM field calculations, including, among others, special design tools tailored for specific applications like complex radomes including FSS, automated design of reflectarrays and ultra-conformed reflector antennas, analysis of Doppler effects, ultrasound systems including automotive or complex RCS, and antenna placement problems. Advanced solver technologies like the MoM combined with the characteristic basis functions (CBFS), PO/GO/PTD, GTD/PO and MLFMM parallelised through MPI/OpenMP, being some of them especially efficient for the analysis of electrically very large problems.

Highlights of the 2020.1 Release

The most notable extensions and improvements to Feko and WinProp.

Salient Features in Feko

- newFASANT is integrated into HyperWorks and included as part of the Feko installation. The newFASANT application can be opened from the Feko Launcher utility.

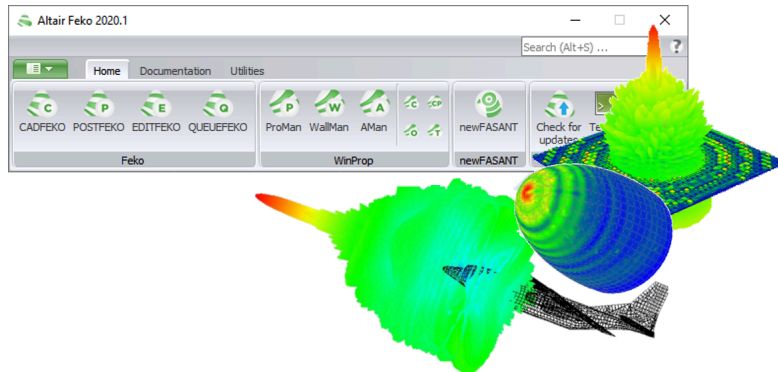

Figure 56: newFASANT is rebranded and integrated into HyperWorks.

- The component library in CADFEKO is expanded with new spiral antennas, RFID tags, an elliptical patch, a TEM horn, a crossed dipole and a slotted waveguide antenna.

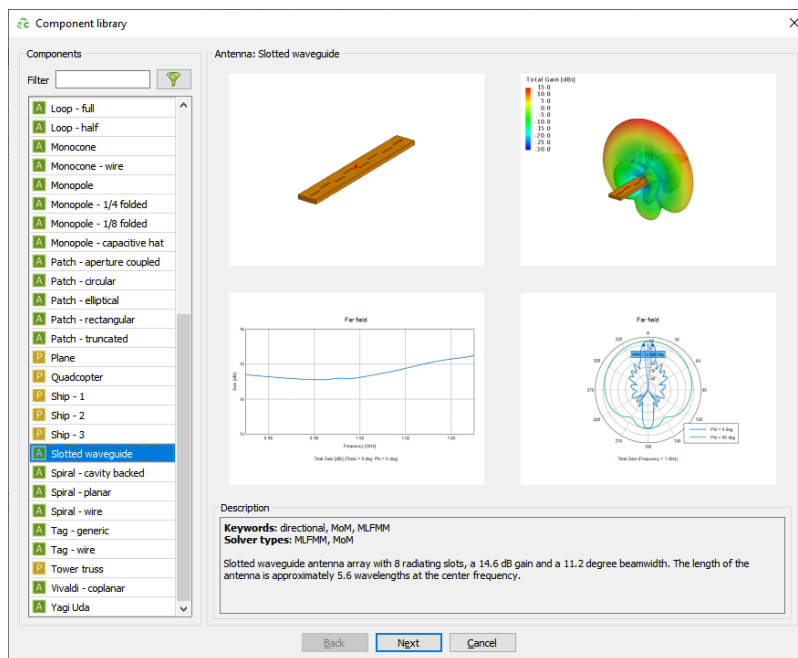

Figure 57: The slotted waveguide antenna is one of the new antennas in the CADFEKO component library.

Salient Features in WinProp

- Extended beam and envelope pattern generation to allow user-defined beams in the elevation domain.

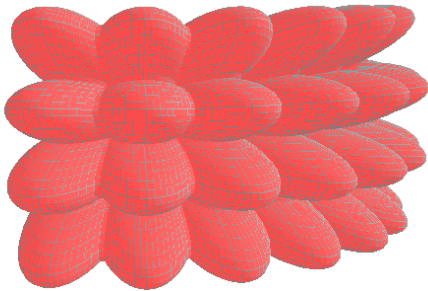

Figure 58: Envelope pattern generated in AMan.

- The orientation of the antenna at the mobile station can now be visualised in ProMan.

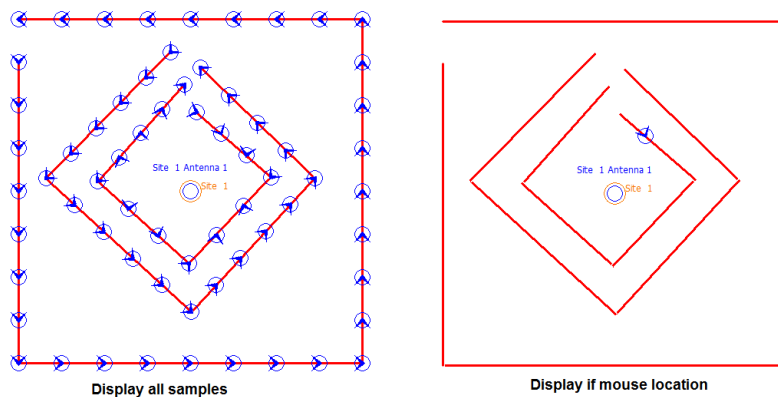

Figure 59: ProMan visualisation of antenna orientation.

- Added support for the definition of up to 64 antenna elements at the mobile station.
- Improved the visualisation of results along trajectories.
- Improved the accuracy of the MIMO condition number calculations. Results show better agreement than before with customer measurements for realistic scenarios.

Feko 2020.1 Release Notes

The most notable extensions and improvements to Feko are listed by component.

CADFEKO

Features

- Added 10 new antennas to the component library, including spirals, RFID tags, an elliptical patch, a TEM horn, a crossed dipole and a slotted waveguide antenna.
- Added an option to the **Create cable path** dialog (**Advanced** tab) for exporting cable parameters such as inductance/capacitance matrices and transfer impedance/admittance to the `.out` file.
- Updated the algorithm that calculates and reports the number of cable segments in a model when meshing to match the latest changes in the Feko solver. The changes relate to the segmentation of twisted pairs, twisted bundles and combined MoM/MTL cable solutions.
- Added the option to swap the source and field validity regions of near field data to be used in a near field source. It is usually assumed that the fields inside the near field source box, sphere or cylinder are zero and the fields outside the box, sphere or cylinder are equivalent to the measured or calculated field values. This option can be used to specify that the field values outside the box, sphere or cylinder are zero and the fields inside the box, sphere or cylinder are equivalent to the measured or calculated field values.

EDITFEKO

Feature

- Added the option to swap the source and field validity regions of aperture sources (AP card).

POSTFEKO

Feature

- Reduced the load time when opening models.

Solver

Features

- Improved the automatic determination of sampling point density along the path of twisted pair or twisted bundle cables by considering the smallest pitch length among twisted cross-sections, leading to accuracy improvements.

- Improved the automatic cable segmentation during a combined MoM/MTL solution by allowing for the outer problem to be discretised using standard MoM meshing rules, and the inner problem to be meshed MTL meshing rules.
- Significantly reduced the memory requirement for simulating FEM models in parallel by exploiting shared memory architecture. Large savings in memory usage can be obtained when large models, with many tetrahedra, are simulated on nodes with many processes. In particular, the memory requirements for storing tetrahedral mesh information are reduced by up to an order of magnitude.
- Improved the solution of the system of linear equations phase with FEM based solvers for parallel simulations leading to faster solutions.
- Improved the peak memory usage of FEM based solvers for parallel simulations leading to lower memory requirements.
- Improved the parallel efficiency of MLFMM solutions of problems with multi-scale meshes.
- Added support for parallel simulations with the direct ACA solver on machines with hybrid (shared/distributed) memory architecture.
- Improved the time efficiency of the calculation of right hand side vector for parallel computations for all solvers except ACA and DGFM solutions.
- Added an option to swap source and field validity regions when a near field source is used.
- Upgraded HyperSpice to the latest version.

Resolved Issue

- Improved the robustness of an MLFMM solution of models with a few unknowns computed using a large number of parallel processes.

Shared Interface Changes

Features

- Increased the `.fek` file version to 173 to accommodate new features.

Support Components

Features

- Included newFASANT (using Altair Units) in the Feko installation. newFASANT gets installed to the same location as Feko. The Feko bin directory and other folder structures are shared.
- Added newFASANT to the Launcher utility.
- Removed the **Licensing** contextual tab from the Launcher utility and made the **Utilities** tab consistent across versions. The Student Edition now also displays a **Utilities** tab. Any item that is not available under the Student Edition will be disabled, with a tooltip indicating that it is unavailable in the Student Edition.

WinProp 2020.1 Release Notes

The most notable extensions and improvements to WinProp are listed by component.

General

Resolved Issues

- Replaced a corrupted zip archive for Project 4 of the Getting Started exercises. The material database valid up to 300 GHz is included with the examples.
- Added missing CoMan examples to the installation.

ProMan

Features

- Added support for the definition of up to 64 antenna elements at the mobile station.
- Improved the visualisation of results along trajectories.
- The orientation of the antenna at the mobile station can now be visualised in ProMan.

Resolved Issues

- An error message is issued when MIMO in a project is disabled by the user while individual MIMO streams are inadvertently still active from an earlier simulation setup.
- Improved the accuracy of the MIMO condition number calculations. Results show better agreement than before with customer measurements for realistic scenarios.
- Fixed a bug that resulted in the transmitter being displayed at the incorrect height in 3D view, in a project with topography (pixel or vector), when results are loaded directly from a file.
- The minimum distance between evaluation points, during mobile station post-processing, is now 0.001 metres.

AMan

Feature

- Extended beam and envelope pattern generation to allow user-defined beams in the elevation domain.

Resolved Issue

- The sign of the polarisation angle is now considered when creating a full polarimetric antenna pattern in AMan.

Application Programming Interface

Features

- Added support for simulations using RCS information in the WinPropAPI.
- Added support for all prediction models associated with radiating cables in the WinProp API.
- Added complete support for CNP simulations in the WinProp API.

newFASANT 2020.1 Release Notes

The most notable extensions and improvements to newFASANT are listed by component.

GUI

Features

- Updated Java 3D libraries for the visualization of 3D geometries.
- Added Feko aperture sources in the MOM module to include files with extensions `.efield` and `.hfield` to be used as an excitation of geometries.
- Enabled the CBFM for radome problems in the MOM module and RCS problems in the MONCROS module.
- Added slotted waveguide array user functions.
- Added new implementation of the Speed Up feature in the MONCROS module.
- Added PBS support for the MOM and GTD modules.
- Added new input parameters to the US module.
- Added multiple sources in the US module.
- Included new CBFM options in the solver parameters to allow more flexible simulations.
- Included a new option to use the SAI for the estimation of the initial currents in the iterative solution process in the MOM and MONCROS modules.
- Removed the requirement for OpenGL when the GUI is launched in server mode.
- Added new parameters to the `newfasant.conf` file to allow a user-customized GUI configuration.

Resolved Issues

- Fixed a problem with the range in the Doppler Spectrum chart.
- Fixed the visualization of GTD results.
- Fixed the visualization of field results in the PE module.

Solver

Features

- Added a new meshing scheme based on the GUI rendering algorithm for the US solver.
- Modified the hybrid technique of the CBFM MPI/OpenMP version for the computation of the reduced matrix using the Multilevel Fast Multipole Algorithm to reduce the CPU time.
- Include the MoM currents for the generation of the CBFs.
- Improved the generation of the CBFs using MoM currents when computing the reduced matrix using MLFMM in the CBFM MPI/OpenMP solver option.
- Improved the criterion to consider infinitely far sources (plane waves) in the GTD/PO solver.

- Updated the selection of CBFS depending on external sources values in the tool that computes the reduced matrix using MLFMM with MPI/OpenMP models.
- Updated the definition of the blocks when using MoM currents with extensions and computing the reduced matrix rigorously in the CBFM MPI/OpenMP models.
- Included the direct solver for the CBFM solver.
- Implemented the SAI preconditioner for the case when the reduced matrix is computed using MLFMA using the CBFM OpenMP solver.
- Introduced the volumetric approximation for the CBFM created by using volume block description and rigorous matrix computation method for the OpenMP solver option.
- Increased to double-precision the product operations performed with the preconditioner (not the storage) for the SAI in MOM solvers.
- Included analysis of volume-defined material structures for CBFS with OpenMP and MPI/OpenMP solvers.
- Modified maximum iteration count for the restarted GMRES in MOM solvers.
- Fixed code to allow working with MESH_SURFACES avoiding remeshing in the GTD/PO solver.
- Added support for the dynamic allocation of the output cuts and angles of the radiation pattern in MOM solvers to reduce memory footprint.
- Improved the surface impedance calculated through the reflection coefficient in all MOM solvers for coated surfaces.
- Improved the ray-tracing when the geometry is modelled with conductor and/or absorbent materials and the transmission effect is enabled in the GTD solver.
- Improved the US solver to consider new parameters in US source pattern.

Resolved Issues

- Fixed a bug in the criterion used to determine if working with a near field or far field simulation in the GTD/PO solver.
- Fixed bug when the source is located at an infinite distance in the GTD/PO solver.
- Corrected some bugs in all configurations (GMRES, Diagonal preconditioner, BICGSTABL, ...) of the CBFM solvers.
- Fixed some bugs found in the sum of the direct fields when several antennas are considered in GTD solver.
- Fixed a bug found when working with materials in the GTD/PO solver.
- Fixed a bug found when checking the edge conditions in the PO solver.
- Fixed a bug found when computing the diffraction contributions in the GTD/PO and PO solvers.
- Fixed a bug found when the transmission contribution is computed in the GTD solver.
- Fixed a bug found when classifying GTD surfaces and checking the possible children patches in the GTD/PO solver.
- Fixed a bug found when the ray-tracing of a double transmission is computing for both near and far field in the GTD solver.
- Fixed a bug found when the reflection point is on the common edge of two coplanar surfaces in the GTD solver.
- Fixed a bug when computing coupling in the US and GTD solvers.

- Fixed a bug when checking occlusions of outgoing tubes for the observation directions considering bistatic simulations in the PO solver.

Altair Feko 2020.0.2 is available with new features, corrections and improvements. This version (2020.0.2) is a patch release that should be applied to an existing 2020 installation.

This chapter covers the following:

- [Feko 2020.0.2 Release Notes](#) (p. 280)
- [WinProp 2020.0.2 Release Notes](#) (p. 282)

Feko is a powerful and comprehensive 3D simulation package intended for the analysis of a wide range of electromagnetic radiation and scattering problems. Applications include antenna design, antenna placement, microstrip antennas and circuits, dielectric media, scattering analysis, electromagnetic compatibility studies including cable harness modelling and many more.

WinProp is the most complete suite of tools in the domain of wireless propagation and radio network planning. With applications ranging from satellite to terrestrial, from rural via urban to indoor radio links, WinProp's innovative wave propagation models combine accuracy with short computation times.

Feko 2020.0.2 Release Notes

The most notable extensions and improvements to Feko are listed by component.

CADFEKO

Features

- Extended I-DEAS universal format (`.unv` file) export to include:
 - Groups for nodes which lie on symmetry planes.
 - Groups for junctions between triangles and segments. This ensures segment-triangle mesh connectivity.

Resolved Issues

- Resolved a defect where configuration-specific looped plane waves were not written out to the `.pre` file correctly for all configurations.
- Added airboxes to some FEM antenna variants in the component library.

POSTFEKO

Features

- Improved the performance of the DRE namespace `DiscoverHierarchy` method when traversing HDF5 files in DRE format with many nested links. The method is extended to return the link type and link target.
- Extended the API with the `ImportSettings` namespace that is nested under the `DRE` namespace. For dataset import and storing custom data from DRE file, this provides support for dBm units and also for dB units with a custom reference level (`dBRef`).

Resolved Issues

- Resolved an issue where the error `Data block not found while parsing *.bof file was given` when opening a `.bof` file without the `.fek` file present.

Solver

Features

- Changed the default iterative solver for MLFMM problems from Bi-CGSTAB to RBi-CGSTAB. This generally leads to improvements in the number of iterations as well as a lower residuum than when the Bi-CGSTAB method is used.
- Improved the robustness of the RBi-CGSTAB iterative solver for many ill-conditioned MLFMM models where convergence was not previously achieved.

- Fixed a bug that sets the impressed spherical modes to zero in the cut-off region for the inward propagation direction.
- Improved the initialization of the Green's function phase by avoiding the redundant calculation of interpolation tables if the radiating sources are the same for multiple configurations.
- Extended the error/warning feedback for overlapping cable path sections and unconnected floating point terminals for SPICE circuit elements.

Resolved Issues

- Fixed a bug that resulted in a floating point exception for models with incident fields and a near field request solved with MLFMM.
- Fixed a bug that resulted in an error state for some models with multiple cable probes defined along different cable paths within the same harness.

Support Components

Feature

- Improved the Feko Scripting and API Reference Guide by displaying method and function input parameters next to the method or function name and adding method-specific and function-specific examples. The input parameters were already displayed next to names in the Method List and Function List sections, but this is now also the case for the Method Details and Function Details sections.

WinProp 2020.0.2 Release Notes

The most notable extensions and improvements to WinProp are listed by component.

General

Feature

- The WinProp plug-in for Forsk Atoll is now available with HyperWorks Units licensing. The plug-in is used by Atoll customers who favor WinProp's propagation simulations.

ProMan

Features

- Added an option to visualise the contour of all buildings in 2D view for an indoor project with a topography database.
- Added full support for the ITU-R P.1411 propagation model.
- Electromagnetic exposure zones (occupational and public) are now available for display in the result tree.

Resolved Issues

- Fixed a bug that resulted in the effects of the direct rays being neglected in urban projects, with topography, simulated with IRT in trajectory or point modes.
- Fixed a bug that resulted in a simulation error in a rural project, with topography defined in geodesic coordinates, where the prediction area is defined to be larger than the extents of the topography.
- Fixed a bug that resulted in an error during network planning due to a mismatch between LOS and power results for projects simulated in trajectory or point modes as well as projects with results on arbitrary prediction planes.
- Fixed the display of the Greek character μ in the legend on computers with Windows in a language with non-Latin characters.

Application Programming Interface

Features

- Added support for the simulation of time-variant projects with the WinProp API.
- Added support for the simulation of projects with time-variant prediction points with the WinProp API.

Release Notes: Altair Feko 2020.0.1

Altair Feko 2020.0.1 is available with new features, corrections and improvements. This version (2020.0.1) is a patch release that should be applied to an existing 2020 installation.

This chapter covers the following:

- [Feko 2020.0.1 Release Notes](#) (p. 284)
- [WinProp 2020.0.1 Release Notes](#) (p. 286)

Feko is a powerful and comprehensive 3D simulation package intended for the analysis of a wide range of electromagnetic radiation and scattering problems. Applications include antenna design, antenna placement, microstrip antennas and circuits, dielectric media, scattering analysis, electromagnetic compatibility studies including cable harness modelling and many more.

WinProp is the most complete suite of tools in the domain of wireless propagation and radio network planning. With applications ranging from satellite to terrestrial, from rural via urban to indoor radio links, WinProp's innovative wave propagation models combine accuracy with short computation times.

Feko 2020.0.1 Release Notes

The most notable extensions and improvements to Feko are listed by component.

POSTFEKO

Features

- Improved the performance of the API `GetDataSet` method for non-radiating networks and certain load types (cable loads and loads on FEM and edge ports). The improvement is especially prominent in models with many looped plane wave directions.
- Reduced the time it takes to import far field, near field, Touchstone and custom data files.

Resolved Issues

- Resolved an issue where importing large near field, far field or custom data files (roughly 1 GByte in size) caused an assertion to fail in versions of Feko 2019. The import of much larger `.efe`, `.hfe` and `.ffe` files (several GBytes in size) is now supported than before Feko 2019.
 - In the Feko 2019.3.3 update (released after Feko 2020) the fix for near field and far field data was released.
 - In this update (Feko 2020.0.1), the fix is extended to include large custom data files.
- Fixed the normalisation of Cartesian boundary near field results plotted on the 3D view.
- Resolved a defect where data for edge loads were not updated for finite antenna array elements. All edge loads in an array shared the data from the first load.
- Fixed a problem where POSTFEKO failed to get the dataset (via the API) from a load if there were multiple models in the session.

Solver

Features

- The maximum allowable non-tissue volume fraction for 1 g/10 g SAR averaging over a cube was changed from 20% to 10% in accordance with the IEC/IEEE 62704-1:2017 standard.
- Improved the multilayer planar Green's function setup for parallel simulations leading to faster solutions.

Resolved Issues

- Fixed a bug that increased the simulation time when using the parallel RL-GO for models that trigger the field matrices to be stored in shared memory.
- A note regarding the accuracy of results is now issued when a receiving antenna is placed too close to geometry or sources.
- Fixed a bug that prevented results in the first configuration from being computed in a model with a load defined by a SPICE netlist.

- Added a mechanism to disable the use of geometric symmetry in a model containing non-radiating networks. This bug previously led to inaccurate results as the use of symmetry with non-radiating networks is not supported.
- Fixed a bug that led to inaccuracies in surface currents computed with MLFMM on a model consisting of a windscreen with a thin metallic coating.
- Fixed a bug that led to incorrect results when PCB sources are defined per configuration, as opposed to the case where they are defined globally for use in all configurations.
- Fixed a bug related to source power calculations in multi-configuration examples where power scaling is enabled in the first configuration and disabled in subsequent configurations.
- Fixed a numerical tolerance bug that resulted in errors when identifying the surrounding medium of mesh elements.
- Fixed a bug that caused spikes in the computed gain when the fast method for far field calculations is enabled for some models.
- Fixed a bug that caused a segmentation violation during the matrix fill stage of an ACA solution for some large models.

Shared Interface Changes

Resolved Issue

- Fixed a problem with the distribution of rendering plugins on Linux.

Support Components

Feature

- Labels from blocks 2435, 2467 and 2477 are now used by PREFEKO for segment and triangle labels when importing UNV files.

Resolved Issue

- Resolved a bug on Linux systems using GNOME Terminal that prevented the Feko terminal to be opened from the Launcher application.

WinProp 2020.0.1 Release Notes

The most notable extensions and improvements to WinProp are listed by component.

ProMan

Features

- Simulation progress tabs for each transmitter are now left open if the option to leave the progress window open is selected. In addition, time stamps associated with each stage of the simulation are now printed to the log file.
- Vector topography data can be included in indoor databases by setting the type of relevant objects to **Topography Triangles**.
- Accelerated the wedge determination phase of database preprocessing or SRT simulation without a preprocessed database by at least one order of magnitude, with faster wedge determination being observed for large databases with many objects.
- Added support for predictions with the ITU P.1411 propagation model in urban scenarios. Support is currently limited to over the roof top predictions for receiver locations that are not in the line of sight of the transmitter.
- Accelerated simulations using ray tracing models in indoor scenarios for projects with databases having no more than 20000 polygons. Large speed-up factors are typically obtained when at least two interactions are used, with orders of magnitude reductions in total simulation time being achieved in some cases.
- Polarization-dependent power results (computed during propagation modelling of fully polarimetric projects) are now available for display in the result tree.

Resolved Issues

- Improved support for Monte-Carlo Analysis in a network planning project with MIMO sites.
- Fixed a bug when accounting for the effects of diffraction wedges during computation of an indoor project consisting of a database that was preprocessed for SRT.
- Fixed a bug that resulted in inaccurate diffraction effects being obtained for some rays in some projects solved with SRT.
- Fixed a bug that resulted in a crash when a very large database is simulated with the IRT.
- Revised parallelisation of the SRT method to only use the specified number of concurrent threads. In a previous version, more threads than requested were used when the specified number of concurrent threads is greater than or equal to the number of transmitters in the project.
- Fixed a bug that resulted in an error when modifying mobile station receiver antenna settings in a project that was created with a 2019 version of WinProp.
- Fixed a bug that resulted in the inclusion of rays which do not meet the dynamic range criteria in regions of a database with low field strength.

WallMan

Features

- Vector topography data can be included in indoor databases by setting the type of relevant objects to **Topography Triangles**.
- Accelerated the wedge determination phase of database preprocessing or SRT simulation without a preprocessed database by at least one order of magnitude, with faster wedge determination being observed for large databases with many objects.

Resolved Issue

- Fixed a bug that resulted in a termination of the WallMan GUI after preprocessing a database for SRT.

Application Programming Interface

Feature

- Added support for indoor database preprocessing for SRT using the WinProp API.

Altair Feko 2020 is available with a long list of new features, corrections and improvements. Altair Feko 2020 is a major release. It can be installed alongside other instances of Altair Feko.

This chapter covers the following:

- [Highlights of the 2020 Release](#) (p. 289)
- [Feko 2020 Release Notes](#) (p. 291)
- [WinProp 2020 Release Notes](#) (p. 294)

Feko is a powerful and comprehensive 3D simulation package intended for the analysis of a wide range of electromagnetic radiation and scattering problems. Applications include antenna design, antenna placement, microstrip antennas and circuits, dielectric media, scattering analysis, electromagnetic compatibility studies including cable harness modelling and many more.

WinProp is the most complete suite of tools in the domain of wireless propagation and radio network planning. With applications ranging from satellite to terrestrial, from rural via urban to indoor radio links, WinProp's innovative wave propagation models combine accuracy with short computation times.

Highlights of the 2020 Release

The most notable extensions and improvements to Feko and WinProp in the 2020 release.

Salient Features in Feko

- Improved parallel scaling performance for the MLFMM.

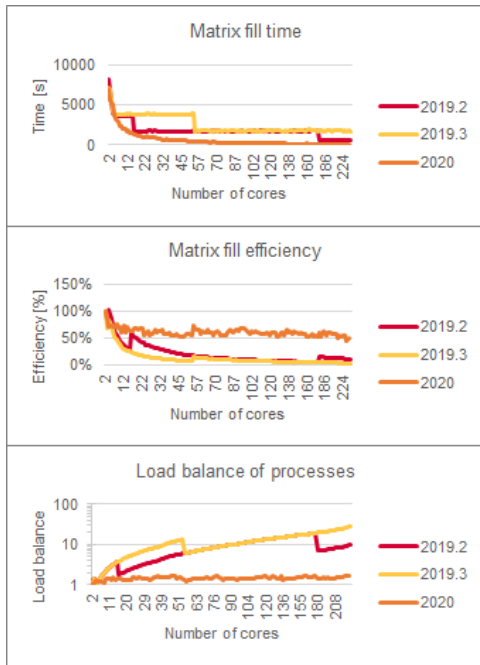

Figure 60: A comparison of the parallel scaling performance of the MLFMM between versions 2019.2, 2019.3 and 2020.

- Parallel processing on distributed memory architecture (MPI) for the direct ACA.
- Improved time efficiency of FEM matrix elements computation.
- Fast cable simulation with the wideband circuit crosstalk solution.
- Tighter integration with other Altair products:
 - A new interface with PolEx SI for the simulation of the radiated emissions of PCBs.

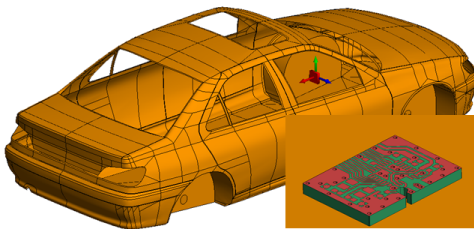

Figure 61: A PCB simulated in PolEx can be included as a source in a Feko simulation.

- A new interface with OptiStruct for thermal analysis.
- A simplified interface with HyperStudy through the use of an existing POSTFEKO session.

Salient Features in WinProp

- A new Command Line Interface (CLI) for submitting jobs to a cluster.
- Easy workflow for co-existence studies.

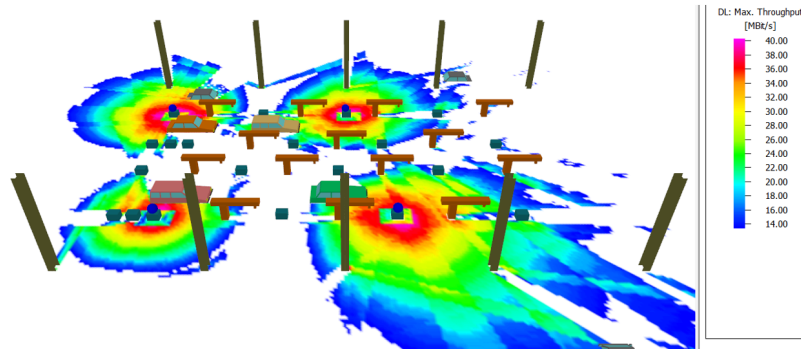

Figure 62: Co-existence between Bluetooth and Wi-Fi in a factory hall.

- Easy workflow for the definition of MIMO sites with multiple antenna elements.
- An updated and unified Example Guide.

Feko 2020 Release Notes

The most notable extensions and improvements to Feko are listed by component.

CADFEKO

Features

- Added a PCB equivalent source that uses printed circuit board current data imported from Altair PolEx.
- Extended the **Solver settings** dialog with an option to export files for thermal analysis when running the Feko solver.
- Extended CEM validate to issue a warning if the wideband circuit crosstalk method could be utilised for cable harnesses, but there are requests in the model that will trigger a full-wave solution.

EDITFEKO

Features

- Added the AJ card for importing printed circuit board (PCB) current data from PolEx. An equivalent source is defined that uses the current data as impressed line currents.
- Extended the DA card (settings for writing additional data files) with the option to export files for thermal analysis.

POSTFEKO

Features

- Added the **Create HyperStudy extraction script** macro to the application macro library. The macro creates the HyperStudy extraction script that reads the trace data from Cartesian or polar graphs in a POSTFEKO session and makes the data available in HyperStudy to be used as an output response or optimisation goal.
- Increased the `.fek` file version to 172 to accommodate new features.
- Added support for the new PCB equivalent source that uses PolEx current data.
- Upgraded the library that is used to export animations. The file size of exported animations in `.gif` format is greatly reduced. The file size of example exports were up to 50 times smaller compared to the previous version using the same export settings. There is also more variation between the different export quality setting for animations in `.mov` format than before, providing better control over the resulting export by using different combinations of the export size and export quality settings.
- Added support for `.mkv` format when exporting animations.
- Improved the implementation of 2D Display OpenGL rendering in POSTFEKO.

 **Note:** Enable OpenGL rendering for 2D graphs to improve performance when interacting with traces that have a large number of points, in particular those that have many overlapping lines.

Solver

Features

- Added support for parallel simulations with the direct ACA solver on machines with distributed memory architecture (parallel support on multiple nodes).
- Substantially improved parallel load balancing for the MLFMM. Models with a combination of fine detail and uniform meshes often resulted in some MLFMM boxes with many more elements compared to other boxes. The non-uniform distribution of elements between boxes could have resulted in a few boxes dominating the solution time and increasing the number of cores would not result in faster solutions. The matrix fill times now scale linearly with the number of cores used for the parallel simulation.
- Improved transfer function computation for MLFMM. Both the memory footprint and the computation time for transfer functions are decreased.
- Decrease the memory footprint for the MLFMM solution phase by using shared memory for matrix by vector multiplication.
- Added support for a wideband solution for cross-talk calculations of cable circuits. A speed-up of up to two orders of magnitude can be observed for the cross-talk calculation phase when comparing to Feko 2019.3.2 where cross-talk was calculated on a per frequency basis. Additionally, improved the efficiency of the overall circuit cross-talk solution by allowing certain phases of a MoM or FDTD cable solution to be skipped in a configuration where only circuit cross-talk is required to be calculated.
- Added support for curvilinear elements in the 2D FEM solution of per-unit-length elements of cable cross-sections.
- Refined the error checking mechanism for validating circuit connections at cable path endpoints to only issue an error message if explicit direct connections across a shield exist in the circuit.
- Improved the integration routines used for wire segments, resulting in a performance improvement for the matrix fill stage of the solution of models with many wire segments.
- Improved the time efficiency of FEM matrix elements computation.
- Power loss in lossy segments, triangles, FEM and VEP tetrahedra, as well as metallic triangles on or in a FEM region are now exported to a `.ep1` file, along with the Cartesian coordinates of the centre of each element, its size and label.
- Added support for using PCB current data calculated in PolIEx as an impressed current source.
- NGSPICE is no longer included in the Feko installation. It can still be used as the SPICE solver in Feko if it is available.
- Continuation lines, represented by the "+" character, can now be used in SPICE netlist definitions.

Resolved Issue

- Fixed a bug that resulted in inaccurate results for an MLFMM solution of models with dielectric faces touching an infinite PEC ground plane.

Shared Interface Changes

Features

- Updated the applications and documentation with the latest Altair branding.
- Introduced new application icons to provide a more uniform appearance across HyperWorks applications.

Support Components

Features

- Upgraded licensing to use the latest Altair License Management System 14.5.1. Components using ALM 14.5.1 require servers running Altair License Server 14.5.1.
- Extended the installer with the End User License Agreement (EULA) shown on the first panel. This requires an update to the response file when running the installer in silent mode.
- Upgraded the version of Java used by the installer to Java™ Runtime Environment, Update 202 (JRE 8u202).
- Extended PREFEKO to read PCB current data from a PolEx .rei file.

Resolved Issues

- Added a check to the installers to prevent overwriting existing installations when installing using console mode on Linux.
- Resolved an issue with the keytips of the Feko Launcher that prevented some actions being performed using keyboard navigation.

WinProp 2020 Release Notes

The most notable extensions and improvements to WinProp are listed by component.

General

Features

- The WinProp Getting Started Guide and WinProp Scripting and API Reference Guide are now available on the Help menu in each WinProp component.
- An updated and unified WinProp Example Guide is now available in PDF and as part of the HTML documentation. It can be accessed from the Launcher utility.
- Updated the location of the WinProp examples. The models are moved to the `ExampleGuide_models` folder inside the examples folder. The new default location of the models is:
`C:\Program Files\Altair\2020\help\winprop\examples\ExampleGuide_models.`

ProMan

Features

- Simplified the workflow for simulation of co-existence of different wireless systems. Results for one wireless system can easily be included in a simulation of another wireless system (and vice versa).
- Simplified the workflow for inclusion of external interference. External interference can be based on the imported propagation result of another project or be defined as a general background noise. The suppression of interference by filters can be specified when applicable, or omitted if the interfering signal is exactly at a carrier frequency of interest.
- Simplified the definition of antenna sites for MIMO. Specifying similar parameters for multiple antennas used to involve repetitive work. The new (optional) MIMO site saves the user setup time and reduces the chance of making occasional mistakes.
- Added the capability to create copies of an antenna from the **Site** dialog in ProMan.
- Some network planning results are now selected by default when a new project is created.
- Added support for moving prediction points in a time-variant database simulated with the IRT model.
- Added support for breakpoint distance and propagation exponent definitions in the SRT model.
- LOS and NLOS exponents are now considered during calibration of the SRT propagation model.
- The minimum power that can be set at the transmitter is now -79 dBm.
- Added support for exporting animations in `.avi` and `.mov` formats, using H.264 and msmpeg4v2 codecs, with the possibility to export animations in different qualities (high, normal and low).

Resolved Issues

- The breakpoint distance of transmitters located directly above buildings is now correctly considered in simulations with the DPM model.

- Fixed a bug when computing the breakpoint distance solving indoor projects that include topography with the dominant path prediction model.
- Fixed a bug in the computation of the breakpoint distance during predictions with the rural dominant path model for projects where either the transmitter or prediction height is chosen to be at an absolute height above sea level.
- Additional gains due to beam-forming are now fully considered in 5G network planning projects.
- Fixed a bug that resulted in a crash during network planning when a project is simulated in trajectory mode and the option to provide additional output for visualisation of data streams is activated.
- Resolution and height of prediction points can now be modified in ProMan for IRT projects with databases preprocessed in point mode.
- Improved the performance of parallel urban IRT predictions by a factor of up to 1.5x. Additionally, resolved issues due to uninitialised variables.
- Fixed a bug which causes propagation paths to be slightly shifted from the pixel centers for urban scenarios solved with DPM.

WallMan

Resolved Issues

- Resolution and height of prediction points can now be modified in ProMan for IRT projects with databases preprocessed in point mode.
- Fixed a bug that resulted in a separate material layer being created for each building when converting a file in the `.shp` format to the WinProp `.odb` format, despite all buildings having the same material properties. This fix improves the time and memory efficiency of database conversion resulting in smaller converted `.odb` databases being generated in a much shorter time than with previous versions.

AMan

Feature

- Improved the functionality to easily generate beams and envelope patterns to include polarization information.

Application Programming Interface

Features

- ProMan simulations can now be run in batch mode, from the command line, using the WinPropCLI executable on Windows or Linux. The WinProp command line interface can be used within queuing systems such as Altair PBS, Torque, LSF and GridEngine.
- Added API support for propagation simulation of trajectories.

- Added API support for simultaneously computing propagation results at multiple receiving points using the `WinProp_Predict_Points` function.
- Added API support for IRT preprocessing based on a user-defined polygonal area for indoor and urban scenarios as well as point-mode preprocessing for urban scenarios.
- Added API support for topo map usage in indoor scenarios.
- Added API support for indoor database preprocessing in point mode.
- Added API support for point mode computations for urban and rural scenarios.
- Added API support for mobile station post-processing.
- Added API support for full polarimetric computations.
- Added several parameters for map data conversion to the API, including support for specifying the coordinate system (various ellipsoidal systems can be specified) as well as the treatment of missing pixels.
- Added API functions to directly export the clutter maps (`.asc`) as well as clutter properties (`.mct`) in ASCII format. The exported clutter maps can readily be converted to the WinProp binary format in WallMan.
- Path loss exponents and breakpoint distance parameters of the SRT model are now accessible via the API.
- Scattering properties of materials are now also considered in the API.
- IRT preprocessing in the API is no longer limited to 9 threads.

Resolved Issue

- The complete settings of SRT prediction model are now available in the API under the `Model_RAYTRACING` struct.

Release Notes: Altair Feko 2019.3.3

36

This version (2019.3.3) is a patch release that should be applied to an existing installation of Altair Feko 2019.

This chapter covers the following:

- [Feko 2019.3.3 Release Notes](#) (p. 298)

Feko 2019.3.3 Release Notes

The most notable improvements to Feko are listed by component.

POSTFEKO

Resolved Issue

- Resolved an issue where importing large near field or far field data files (roughly 1 GByte in size) caused an assertion to fail. Added improved support for importing much larger `.efe`, `.hfe` and `.ffe` files than before (several GBytes in size).

Altair Feko 2019.3.2 is available with new features, corrections and improvements. This version (2019.3.2) is a patch release that should be applied to an existing 2019 installation.

This chapter covers the following:

- [Feko 2019.3.2 Release Notes](#) (p. 300)
- [WinProp 2019.3.2 Release Notes](#) (p. 303)

Feko is a powerful and comprehensive 3D simulation package intended for the analysis of a wide range of electromagnetic radiation and scattering problems. Applications include antenna design, antenna placement, microstrip antennas and circuits, dielectric media, scattering analysis, electromagnetic compatibility studies including cable harness modelling and many more.

WinProp is the most complete suite of tools in the domain of wireless propagation and radio network planning. With applications ranging from satellite to terrestrial, from rural via urban to indoor radio links, WinProp's innovative wave propagation models combine accuracy with short computation times.

Feko 2019.3.2 Release Notes

The most notable extensions and improvements to Feko are listed by component.

CADFEKO

Features

- Extended the CADFEKO API with the following method and properties:
 - Added the `GetRequestPointsAsCartesian` method to the `NearField` object. This method returns a table of the request points converted to Cartesian coordinates. It applies to near field requests with the `DefinitionMethod` set to `Cartesian`, `Conical`, `Cylindrical`, `CylindricalX`, `CylindricalY` or `Spherical`.
 - Added the `SurroundingMedium` property to the `Edge` object. This property retrieves the surrounding medium of a wire. It only applies to free edges (wires).
 - Added the `Length` property to the `MeshCurvilinearSegmentWire`, `MeshSegmentWire` and `Edge` objects. This property retrieves the total length of a wire or an edge.
- Extended export to I-DEAS universal format (`.unv` file) to include wire segment medium information and voltage sources on wire ports.

Resolved Issues

- Fixed a regression in CADFEKO 2019.3 where cancelling CEM validation resulted in a crash. CEM validation cannot be cancelled.
- Resolved a problem, on Linux, that caused the application to become unresponsive when launching the Feko Solver from CADFEKO after creating a voxel mesh.
- Resolved the problem that the position property of a cable connector could not be accessed from the Lua API following KBL import.
- Resolved a problem with the **Create connector** dialog not always detecting the creation of new variables.
- Removed the **Sample on edges** option from the **Request near fields** dialog for near field requests using the **Cartesian boundary** definition method. All Cartesian boundary near field requests are now sampled on edges.
- The **Default wire radius** can now be set on the **Import mesh** dialog (**Advanced** tab) when importing a mesh in I-DEAS universal format (`.unv` file).

POSTFEKO

Resolved Issues

- Improved loading performance for models containing a large number of far field receiving antennas.

- Resolved an issue that was introduced in POSTFEKO 2019.2 that prevented the 3D view rendering of near field samples representing a line (single varying axis). Rendering of surfaces was not affected.
- Introduced an error message when attempting to plot an invalid Cartesian boundary near field on a 3D view. This prevents an assertion failing with the message `src/common_MessageWindowDialogLogger.cpp (155): Assertion failed: pMessage` when plotting the results of a partially requested Cartesian boundary near field.
- Improved rendering of both near field receiving antennas and equivalent sources when models are specified in non-SI units.

Solver

Resolved Issues

- Improved the memory efficiency of the shared memory (OpenMP) parallel ACA solver by avoiding unnecessary memory allocations.
- Fixed a bug in the RL-GO solution that caused inaccuracies in the edge or wedge detection phase for certain models with thin elongated curvilinear triangles. The inaccuracies were caused by considering diffraction effects at specific incident angles.
- Fixed a bug when reporting the storage requirements of a large FEM matrix with the number of non-zeros exceeding the 4-Byte integer limit.
- Fixed a bug that could have resulted in a non-unique SPICE voltage device name when creating a zero Ohm LC load defined in series with a cable source (AK card). The non-unique SPICE device name would have resulted in an error while parsing the SPICE netlist.
- Fixed a bug that triggered an error when a wire port is inside a MoM VEP region.
- Improved the performance of geometry export to the NASTRAN format to scale better with the size of the mesh.
- Fixed a bug where the Kernel exported curvilinear segments as planar segments to NASTRAN file.
- Improved validation to provide an error when characteristic mode analysis is used in combination with shielding applied to a thin isotropic dielectric sheet or dielectric/magnetic coating.
- Improved the robustness of a PBC solution with a plane wave excitation with respect to user-defined phase shift. Phase shift considerations are now more consistent whether the phase shift is determined automatically or defined manually.
- Requested near field or far field samples that are located below an infinite ground plane are now written as zero in the corresponding `.efe`, `.hfe`, `.ffe`, `.isd`, `.fse` or SEMCAD `.dat` output files. Previously these samples were omitted from the output files.
- The transformation of aperture field sources into impressed spherical modes is now done automatically depending on the sampling of the near field source. In particular, aperture field sources are transformed to spherical modes if the near field sampling is smaller than a quarter of a wavelength.
- Corrected the handling of scale factors for aperture and radiating antenna sources (AP/AR cards) defined with irregular grid spacing.

Support Components

Feature

- Improved PREFEKO performance by avoiding unnecessary processing.

WinProp 2019.3.2 Release Notes

The most notable extensions and improvements to WinProp are listed by component.

ProMan

Features

- The effects of earth curvature are now considered for satellite transmitters in rural scenarios.
- The transparency of the topography can now be modified in the 3D view.

Resolved Issues

- Improved error handling to report the problem that led to a simulation error when using the API in rural scenarios.
- Results from a previous simulation are no longer displayed in ProMan once different settings are applied to a project.
- Fixed a bug that resulted in differences in delays and phases computed during propagation modeling and those calculated during post-processing with an omni-directional antenna at the mobile station.
- Fixed a bug that resulted in inaccurate elevation angle calculations at mobile stations in the line of sight of the transmitter for simulations of rural projects with the deterministic two ray model. Moreover, the number of significant digits, used to represent elevation angles in the `.str` file, is increased to improve the accuracy of radian to degree conversions.
- Fixed a bug that resulted in coherent superposition for rays not being correctly considered in urban IRT simulations.
- Fixed a bug that resulted in inaccurate elevation angle calculations at mobile stations in the line of sight of the transmitter when performing DPM simulations on models with topography.
- For time-variant indoor scenarios with topography, the transmitter now follows the topography correctly.
- Fixed a bug that resulted in a crash when simulating a project with a `.tdv` database containing only topography.
- Fixed a problem that occurred in specific cases where, after auto-calibration, there was a larger mean value when comparing prediction (using the calibrated parameters) with measurements in ProMan than reported in the calibration result dialog.
- Fixed a bug that led to an error state when using the option to save propagation results in a separate directory per transmitter.
- Fixed a bug that resulted in incorrect phase information being written to the `.str` file, during post-processing with RunMS, in case of full polarimetric projects. Additionally, fixed a bug when considering phase information due to antenna offset at the mobile station.

WallMan

Resolved Issue

- Fixed a bug that resulted in vegetation being assigned the high loss properties of default building materials when converting a `.osm` database to the WinProp `.odb` format.

Application Programming Interface

Resolved Issues

- Improved error handling to report the problem that led to a simulation error when using the API in rural scenarios.
- Fixed a bug that led to interactions not being computed as well as incorrect angles being written to the ray matrix when the option to write additional results is disabled during a rural scenario simulation with the API.
- Fixed a bug that led to a crash when the number of clutter classes is not specified when loading clutter data from memory with the WinProp API.

Altair Feko 2019.3.1 is available with new features, corrections and improvements. This version (2019.3.1) is a patch release that should be applied to an existing 2019 installation.

This chapter covers the following:

- [Feko 2019.3.1 Release Notes](#) (p. 306)
- [WinProp 2019.3.1 Release Notes](#) (p. 307)

Feko is a powerful and comprehensive 3D simulation package intended for the analysis of a wide range of electromagnetic radiation and scattering problems. Applications include antenna design, antenna placement, microstrip antennas and circuits, dielectric media, scattering analysis, electromagnetic compatibility studies including cable harness modelling and many more.

WinProp is the most complete suite of tools in the domain of wireless propagation and radio network planning. With applications ranging from satellite to terrestrial, from rural via urban to indoor radio links, WinProp's innovative wave propagation models combine accuracy with short computation times.

Feko 2019.3.1 Release Notes

The most notable improvements to Feko are listed by component.

CADFEKO

Resolved Issue

- Resolved an issue where the Optenni Lab plugin terminated with the error `attempt to index field "FarField" (a nil value)`.

POSTFEKO

Resolved Issue

- Fixed a problem affecting Linux platforms where using OpenGL rendering for 2D graphs caused the application to crash.

WinProp 2019.3.1 Release Notes

The most notable extensions and improvements to WinProp are listed by component.

ProMan

Features

- Implemented an initial algorithm for beam assignment for 5G, where phased-array antennas can switch among many possible beams and even employ multiple beams. For each pixel (mobile station) the full algorithm for the cell assignment is used for each of the antenna patterns available at the base station. Open the **Edit Project Parameter** dialog and click the **Air Interface** tab to specify cell-assignment criteria based on signal level or SNIR. The best cell/carrier/beam will be selected based on the results of the cell assignment.
- Implemented an option to avoid long simulation times for 5G models in which phased-array antennas may employ multiple beams. This is controlled with the **Apply Antenna Masking for Network Planning** check box on the **Edit Project Parameter** dialog, **Network** tab. If selected:
 - **Propagation** results are computed and presented based on an isotropic pattern.
 - **Network Planning** can efficiently use multiple different antenna patterns by “masking” (adjusting) the propagation results according to those patterns.

If not selected, **Propagation** results are based on an actual pattern and network planning uses that pattern for both control and data.

- Envelope patterns for control and for data can now be different from each other.
- Enhanced the set of results that is produced during EMC analysis of a network planning project. The result tree will show two types of results. The results related to human-safety standards are listed under **EMF**. These are the same results as before carrying a new label. The new results related to an electromagnetic compatibility standard can be found under **EMC**.
- The effects of the curvature of the earth are now considered in point-mode predictions with the dominant path model in rural scenarios.

Resolved Issues

- Fixed a bug that treated every antenna in the components catalogue as an isotropic (omni-directional) antenna.
- Fixed a bug where, if one combined vegetation with a courtyard, one could get diffractions at the vegetation. Vegetation is not supposed to have such interactions.
- Fixed a bug that led to higher received power being obtained when Fresnel coefficients are used for propagation computations of a full polarimetric project that uses an omnidirectional antenna as transmitter.
- Fixed a bug that prevented the use of the student edition of WinProp.
- Coherent superposition of the electric field is now correctly considered in the deterministic two-ray propagation model.
- Fixed a bug that led to a crash when carrying out auto calibration of the SRT propagation model.

- Fixed a bug in the consideration of phase information, due to geometrical positioning of array elements, during the computation of the MIMO condition number in a full polarimetric project.
- Fixed a bug that resulted in the same elevation angles being computed for the direct and ground reflected rays, for a project solved with the deterministic two-ray model.
- Antennas with input power larger than -80 dBm are now also considered during network planning. This value is aligned with the limit used for propagation computations. Previously, a minimum input power of -40 dBm was required for an antenna to be used in network planning.
- Fixed a bug that caused the phase of the field reported in some RunMS results, such as **Channel Matrices per Point**, to differ from the correct phase reported in the `.str` file.

WallMan

Feature

- Added support for automatically shifting buildings atop the topography when an urban database, including topography, is converted to an indoor database.

Resolved Issues

- Streamlined and modernized the code for intelligent ray tracing (IRT) pre-processing, which resulted in a speed-up. Furthermore, the pre-processing can now be done on many more parallel threads than before, and can also be done in parallel on Linux through the WinProp API.
- The default values for the scattering matrix in the material catalogue have been set to $S_{vv} = S_{hh} = 0.1$ and $S_{vh} = S_{hv} = 0.01$. The value of 0.1 brings these entries in agreement with the default value for the empirical scattering loss of 20 dB.

CompoMan

Resolved Issue

- Fixed a bug that treated every antenna in the components catalogue as an isotropic (omni-directional) antenna.

Application Programming Interface

Feature

- Added support for Monte Carlo analysis for 5G applications to the WinProp API.

Resolved Issue

- Fixed a bug that resulted in an error when converting an open street map (`.osm`) database into WinProp's binary format through the API.

Altair Feko 2019.3 is available with new features, corrections and improvements. It can be applied as an upgrade to an existing 2019 installation, or it can be installed without first installing Altair Feko 2019.

This chapter covers the following:

- [Highlights of the 2019.3 Release](#) (p. 310)
- [Feko 2019.3 Release Notes](#) (p. 312)
- [WinProp 2019.3 Release Notes](#) (p. 316)

Feko is a powerful and comprehensive 3D simulation package intended for the analysis of a wide range of electromagnetic radiation and scattering problems. Applications include antenna design, antenna placement, microstrip antennas and circuits, dielectric media, scattering analysis, electromagnetic compatibility studies including cable harness modelling and many more.

WinProp is the most complete suite of tools in the domain of wireless propagation and radio network planning. With applications ranging from satellite to terrestrial, from rural via urban to indoor radio links, WinProp's innovative wave propagation models combine accuracy with short computation times.

Highlights of the 2019.3 Release

The most notable extensions and improvements to Feko and WinProp in the 2019.3 release.

Salient Features in Feko

- The solve phase of the direct ACA solver now supports parallel processing on shared memory architecture (parallel support on a single node). The efficiency is problem dependent, but a representative model with approximately two hundred thousand unknowns showed an efficiency of more than 75% when using 14 cores. The same model shows an efficiency of more than 90% with 5 cores. Parallel support for the matrix fill phase is not yet supported, but this is typically a less dominant phase in the solution with a smaller contribution to the total simulation time.
- The MLFMM parallel scaling performance in terms of memory usage and simulation time is improved for architectures with many cores. Simulations using 64 cores (2 nodes with 32 cores each) showed that some models ran in half the time (twice as fast) and others saved up to 40% of the memory compared to the previous version (2019.2.1). The improvements are model dependent and in some cases the resource requirements remain unchanged. The improvements are more prominent as the number of cores are increased and for models that have a uniform distribution of mesh elements among MLFMM boxes.
- In CADFEKO, a component library provides access to a collection of antenna and platform models. The component library provides a set of standard antennas and generic platforms for analysis. The antennas can be scaled for the frequency of interest and are constructed for the specified solution method. There are 28 antennas and eight platforms in this release.

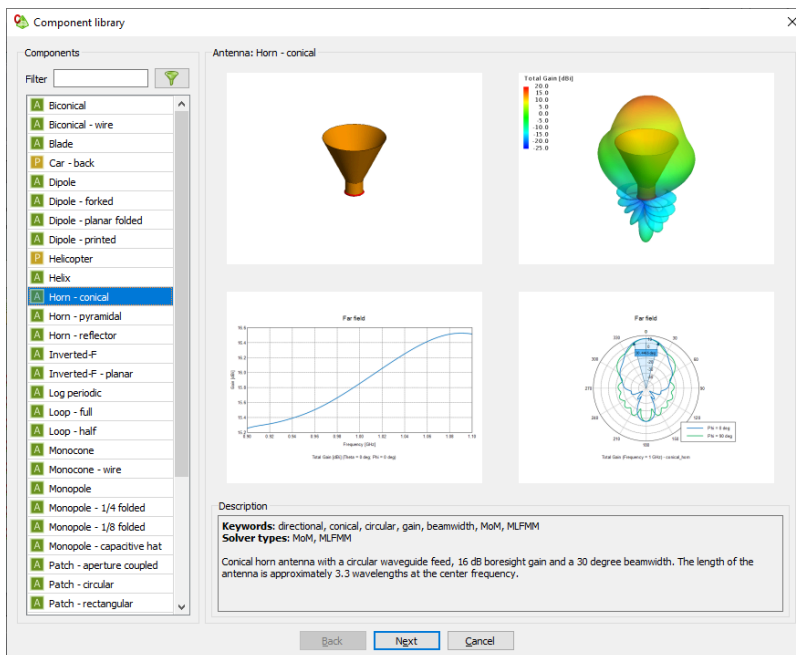

Figure 63: The new component library.

Salient Features in WinProp

- Added support for predictions on a trajectory with varying heights for urban scenarios.

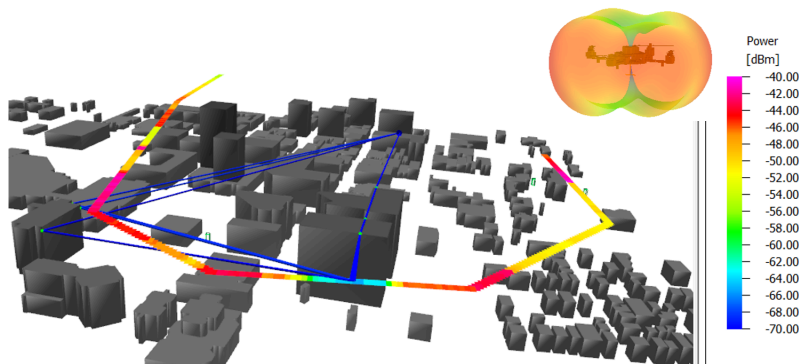

Figure 64: An illustration of a virtual flight test as an example of a 3D trajectory in an urban scenario.

- Added support for predictions on a trajectory with varying heights to the dominant path model in all scenarios (indoor, urban and rural).
- Enhanced standard ray tracing with the ability for rays to interact with pixel-based topography.
- Added support for easy antenna pattern generation, consisting of envelope and individual beam patterns, for 5G applications.

Feko 2019.3 Release Notes

The most notable extensions and improvements to Feko are listed by component.

CADFEKO

Features

- Introduced a component library that contains a collection of antenna models and platform geometry. The component library can be used to add a component to a new or existing model. When browsing through the components, preview images of the geometry and antenna characteristics are displayed. For antenna models, the centre frequency, solver method and other settings can be changed to facilitate model setup.
- Extended the **Solver settings** dialog (**Advanced** tab) to allow selecting between the **Use standard full-rank factorisation** option or **Use block low-rank (BLR) factorisation** option for the parallel Feko solver. For some classes of models with the MLFMM and/or FEM solution methods, the **Use block low-rank (BLR) factorisation** option can reduce the complexity of the factorisation and the memory footprint of the sparse LU-based preconditioners.

Resolved Issues

- Improved the performance when meshing a model containing multiple parts, many faces in multiple parts and one or more cable paths with the setting **Refine mesh close to cable terminals** enabled. Note that creating a union of all geometry parts in a model could speed up meshing.
- Revised the message window output to print the number of cable segments in a model only once during meshing, instead of repeating the information for each part in the model. The number of cable segments is no longer reported in the message window when importing or unlinking a mesh.
- Fixed a bug that resulted in the wrong number of samples being used for the parameter sweep variable grid option if the user added samples and then reduced the number of samples again. The grid entries are now correctly updated.
- Extended the parameter sweep script to read the parallel run options with the correct authentication method from the component launch settings. The run command in the run script uses the `nodes` machines file that is copied from FEKO_USER_HOME to the parameter sweep folder.
- Added support for using Tab to navigate into tables. This improves keyboard navigation for various dialogs, including the **Application macro library**, the **Media library**, the **Modify multiple variables** dialog and the **Find cable instance** dialog.

EDITFEKO

Features

- Extended the **CG - Set preconditioner and solver options** card to allow selecting between the **Use standard full-rank factorisation** option or **Use block low-rank (BLR) factorisation** option when using the parallel Feko solver.

Using the **Use block low-rank (BLR) factorisation** option for some classes of models with the MLFMM and/or FEM solution methods, the complexity of the factorisation and the memory footprint of the sparse LU-based preconditioners can be reduced.

POSTFEKO

Resolved Issues

- Made the following improvements to annotations:
 - Fixed a bug where only half of a delta annotation was shown on a half polar graph.
 - Improved annotation text for half power, first null and null to null beamwidth annotations to allow differentiating between them on a graph.
 - Improved delta annotations on polar graphs to always display the full calculated values regardless of axis graph range setting.

Solver

Features

- Improved parallel run time scaling of parallel MLFMM solutions.
- The block low rank approximation of sparse LU preconditioners for FEM, MLFMM, FEM/MoM, FEM/MLFMM problems is now selected automatically depending on its applicability to a model or whether a solution is performed in-core or out-of-core.
- Improved the time efficiency of a parallel MLFMM solution with a large number of processes.
- Reduced memory usage for parallel MLFMM solutions. Reductions in memory usage of at least 10% can be obtained for typical models.
- Added support for parallel simulations with the direct ACA solver on machines with shared memory architecture (parallel support on a single node).
- Enabled reporting the condition number of the MoM impedance matrix to the `.out` file for parallel simulations, when the environment variable, `FEKO_CALCULATE_CONDITION_NUMBER`, is set.
- Reduced inter-process communication when performing matrix-vector multiplications during an MLFMM solution.
- Improved the time efficiency of the iterative solution phase of a model solved with MLFMM.
- Improved Nastran export by exporting a unique list of nodes followed by the elements instead of exporting the nodes for each element separately. This reduces the size of the exported files.
- Improved Nastran export to ensure that element IDs are not re-used in different element types.

- The CPU time for calculation of matrix elements is now also printed to the `.out` file prior to the solution of linear equations for models solved with MoM, FEM, ACA and MLFMM. Previously the time taken for this phase of the solution was only printed to the `.out` file at the end of a successful simulation.
- The name and end point coordinates of the cable whose end point coincides with metallic geometry are now reported in the `.out` file.

Resolved Issues

- Improved the robustness of RL-GO solution against tilted complex waves that may be generated by reflected rays in some models. Inaccuracies due to tilted complex wave effects when adaptive ray-launching is used in a solution have been resolved.
- Fixed a bug that resulted in variations in computed results between subsequent runs of an RL-GO solution on a heavily loaded machine.
- Fixed a bug in the computation of received power with a receiving antenna in a model solved with RL-GO.
- Fixed a bug when evaluating the scalar electric and magnetic potentials in non-Cartesian coordinate systems.
- Fixed a bug in the computed error estimates of a model containing PEC FEM tetrahedra.
- Fixed a bug that resulted in an error state during the linear equation solution phase of a FEM simulation.
- Fixed a bug that resulted in an error state when the common node of two intersecting wire segments touch the PBC boundary.
- Improved the accuracy of the computed radiated power for models that use a coarsely sampled far field point source as excitation.

Shared Interface Changes

Features

- The `.fek` file version is increased to 171 to accommodate new features.

Support Components

Features

- Added support for zip files when updating from a local repository. The local repository can now be specified as a folder that can contain extracted files or multiple zip files, or as a single downloaded repository zip file. In the past, a local repository could only be specified as a folder containing extracted archives.
- File associations are now created for different WinProp file types during the installation process.

Resolved Issues

- Fixed a bug that resulted in an error state when reading large files generated by OPTFEKO.

- Resolved an issue where optimisation masks containing thousands of points resulted in OPTFEKO terminating immediately following the message `OPTIMISATION WITH FEKO.`

WinProp 2019.3 Release Notes

The most notable extensions and improvements to WinProp are listed by component.

General

Features

- During installation, file associations can now be updated for WinProp modules. The file associations are created by the 2019.3 (and later) installation.

ProMan

Features

- Radio planning of single-hop wireless communication networks based on the LoRa/LPWAN standard is now supported.
- Added support for point mode predictions with the COST and knife edge models in urban scenarios.
- Added support for point mode predictions with the urban IRT model.
- Added support for point mode computations with the dominant propagation model in urban scenarios.
- Standard ray tracing is enhanced with the ability for rays to interact with pixel-based topography.
- Added support for point-mode computations with the dominant path model in urban scenarios.
- Added support for point-mode computations with the dominant path model in indoor scenarios.
- Added support for point-mode simulations with the dominant path model in rural scenarios.
- Reflections at the wedges of a wall are now discarded when propagation simulations are carried out with the standard ray tracing model.
- Increased the maximum frequency that can be specified for a transmitter or material properties to 300 GHz.
- Added support for predictions on a trajectory with varying heights for urban scenarios.
- The parabolic equations solver now considers the electrical properties of ground as one default material or as individual material properties that are defined in clutter data.

Resolved Issues

- Fixed a bug that prevented the display of results on prediction planes in time-variant scenarios.
- Fixed a problem in opening map data and results from a much older WinProp version, WinProp 13.5.
- Network planning results are now computed along a trajectory with variable heights.
- Fixed a bug that prevented time-variant results from being displayed from a certain time step on when the Z coordinate of the prediction point changes.

- Fixed a bug that resulted in the inability to compute coverage predictions of a model with radiating cables and transmitter components.
- Fixed a crash when generating reports from a project involving elements from the components catalogue.
- Fixed a bug that resulted in the inability to predict propagation for a project consisting of a mixture of antennas and radiating cables.
- Revised calculations of the power azimuth spectrum to be more in line with the ratio of the power in each ray impinging upon a given receiving point.
- An error message previously issued when connecting components with cables has been resolved.
- Fixed a bug when computing the percentage of allocated resources during a Monte Carlo analysis. Percentages higher than 100% were previously obtained in special cases of uplink-only analysis.
- Mobile station transmit power is now split over the number of active resource blocks in the uplink direction during Monte Carlo analysis.
- Significantly improved the loading time of results on prediction planes.
- Fixed a bug that resulted in the inability to display clutter classes in indoor scenarios.
- In the setup of transmitter antennas based on `.ffe` files, the GUI can now display the theta-polarized, phi-polarized and total gain of the selected patterns.

WallMan

Features

- Added support for 3D trajectory import in WallMan, including yaw, pitch and roll angles.

Resolved Issues

- Enhanced the robustness of database conversions of topo maps in the GeoTIFF format.

AMan

Features

- Added support for antenna pattern generation, consisting of envelope and individual beam patterns, for 5G applications.
- Envelope and individual beam patterns, for 5G applications, can now be easily defined and generated in AMan.

Application Programming Interface

Features

- A directory containing only the binaries needed for the WinProp API is now available in `%FEKO_HOME%\api\winprop\bin\.`

- Clutter data can now be written to an ASCII file with a function provided through the WinProp API.

Resolved Issues

- Fixed a crash in the WinProp API that could occur on Linux in the function `GetLibraryPath()`.

Release Notes: Altair Feko 2019.2.2

The most notable improvements to WinProp are listed by component.

This chapter covers the following:

- [WinProp 2019.2.2 Release Notes](#) (p. 320)

WinProp 2019.2.2 Release Notes

The most notable extensions and improvements to WinProp are listed by component.

ProMan

Resolved Issues

- Fixed a bug that prevented RunMS from working.
- Fixed a crash that could occur in a hybrid urban/indoor scenario with empirical indoor penetration.
- The loss in furniture floating above ground is now correctly considered during predictions.
- Fixed a crash that could occur, for certain models, in an "indoor" scenario with topography.
- Added support for indoor predictions using the "IRT Coverage Model" in an urban scenario simulated with IRT.

WallMan

Resolved Issues

- Fixed a problem where subdivisions in a wall could not be created due to a slight mismatch between the coordinates of the existing wall and the entered subdivision. The robustness of such checks in the geometry has been improved.

Application Programming Interface

Resolved Issues

- Fixed a bug that led to propagation results of the last time step being incorrect for a time-variant indoor scenario simulation with the WinProp API.
- Fixed several memory leaks in the WinProp API.

Release Notes: Altair Feko 2019.2.1

41

Altair Feko 2019.2.1 is available with new features, corrections and improvements. This version (2019.2.1) is a patch release that should be applied to an existing 2019 installation.

This chapter covers the following:

- [Feko 2019.2.1 Release Notes](#) (p. 322)
- [WinProp 2019.2.1 Release Notes](#) (p. 326)

Feko is a powerful and comprehensive 3D simulation package intended for the analysis of a wide range of electromagnetic radiation and scattering problems. Applications include antenna design, antenna placement, microstrip antennas and circuits, dielectric media, scattering analysis, electromagnetic compatibility studies including cable harness modelling and many more.

WinProp is the most complete suite of tools in the domain of wireless propagation and radio network planning. With applications ranging from satellite to terrestrial, from rural via urban to indoor radio links, WinProp's innovative wave propagation models combine accuracy with short computation times.

Feko 2019.2.1 Release Notes

The most notable extensions and improvements to Feko are listed by component.

CADFEKO

Features

- Added API support for importing cable data from a .kbl file.
- Extended export to I-DEAS universal format (.unv file) to include media information.
- Changed the default format on the **Import near field** dialog from **Sigrity** to **Feko Solver field on Cartesian boundary**. Please modify Lua scripts that rely on the default by explicitly setting the `DataType` property of the `NearFieldDataFullImport` object.

Resolved Issues

- Resolved a crash that could be encountered when running a Lua script that makes use of form dialogs to gather user input.
- Added validation to prevent modifying a medium that is used by a locked mesh part. This caused an assertion failing with the message `src\mediaframework\gaia_MediaLibrary.cpp (751): Assertion failed: 0.`
- Fixed a bug where, when running the command-line mesher (CADFEKO_BATCH) on a machine with locale settings that use a comma (,) as the decimal separator, the setting for using higher order basis functions was ignored. This resulted in a significantly larger number of mesh elements than expected.
- Fixed a regression that got introduced in CADFEKO 2018.1 that made the radius of model mesh segments non-modifiable.
- Fixed a problem with the renaming of cable elements through automation where the labels in the tree and the 3D view did not update correctly.
- Resolved a problem with the updating of a cable harness label following a rename. The label from before the rename was written to the .pre file for the cable cross section definition(s). Instances of the old label and of the new label could be observed in the POSTFEKO model browser. The updated label was correctly written out after the model was closed, re-opened and saved. The correct labels are now used consistently.
- Resolved an issue in the CADFEKO API with the recently introduced `ClosestVertexTo` method. This method can now be used for the `CurvilinearSegments` and `CurvilinearTriangles` objects to provide the vertex nearest to a specified point.

EDITFEKO

Resolved Issues

- Corrected the FF card to recognise the value when selecting the option to **Calculate only the scattered part of the field** for far fields using Cartesian coordinates.

- Corrected the CR card labels for **Position (coordinate)** and **Rotation about the axes**. The position and rotation are specified in Cartesian coordinates, regardless of the coordinate system setting. The coordinate system determines how the tensor is interpreted.

POSTFEKO

Features

- Changed the default **Quantity** settings (for example, **dB** and **Normalise**) in the Result palette when adding a result to a graph or 3D view that already contains a result of the same type. POSTFEKO will apply the **Quantity** settings from the last request of the same result type to the newly added result. There is no change to the default **Quantity** settings for the first result that is added to a graph or view.

For example, if a Cartesian graph already contains an S-parameter result in dB, the next S-parameter result added to the Cartesian graph will also be plotted in dB.

In cases where existing Lua scripts used the default settings, executing the script may fail, or graphs and 3D views could display the wrong quantities. The scripts should be modified to explicitly set the required quantities.

- Extended the API with the DRE namespace that provides an interface to import/export results from HDF5 files in the DRE format.

Resolved Issues

- Fixed a crash that could be encountered when viewing optimisation results plotted on a Cartesian graph while running the optimiser.
- Resolved a crash that could be encountered when restoring the POSTFEKO window after executing a script that plots results while the application is minimised.
- Resolved a crash that could be encountered when running a Lua script that makes use of form dialogs to gather user input.
- Resolved an issue with bi-static RCS values that were plotted incorrectly when the source used the setting **Calculate orthogonal polarisations** and the `.fek` file was present.
- Resolved an issue where the slicing panel did not include the **Polarisation angle** when multi-selecting far field and stored far field traces.
- Resolved an issue where setting the animation type was not stored correctly and would reset to the first item in the drop-down list. For example, setting the animation type to **Phase** and changing the selection or selecting to export the animation would change the animation type to **Frequency**.
- Resolved a performance problem when selecting a result in the tree belonging to a model that contains multiple looped plane wave sources or a characteristic mode analysis request. The previous slow performance was caused by validation checks that are carried out to determine whether the results are valid for export. After the change, the slow behaviour will only be experienced when selecting to export a result from such a model. The results can now be plotted without delay.
- Resolved an assertion that failed with a message referring to `common_AxisSet.h` when exporting a custom dataset containing an axis with string values.

- Fixed an assertion that could fail in POSTFEKO 2019.2 with the message `Assertion failed: delta.isEmpty()` when interacting with a 2D graph from a `.pfs` file saved in an older version.
- Resolved an assertion that failed when adding electric or magnetic scalar potential near fields (the scalar values, not the gradients) to a graph with only the `.bof` file present.
- Resolved an assertion that failed with message ending in `common_MultiAxisSet.cpp (89): Assertion failed: isSingular()`. This assertion failure could be encountered when opening a model containing multiple near field requests with the same label (in different configurations) where at least one of the requests was a Cartesian boundary near field with multiple surfaces.
- Fixed the API `DataSetAvailable` property on the `NearFieldData` object to correctly return false for a Cartesian boundary request with multiple surfaces. This request type is not currently supported in the API.
- Added validation that prevents getting the data set of a Cartesian boundary near field with multiple surfaces. The API is not yet extended with support for Cartesian boundary near field data sets. An assertion could fail in POSTFEKO 2019.2 with the message `Assertion failed: markedMultiAxisSet.hasSingleMarkedAxisSet()` if the `GetDataSet` method was used on a Cartesian boundary near field result.
- Resolved an issue where using `StoreData` to save a result as a different dataset type resulted in the dataset being stored despite an error being given. For example, storing a near field dataset as a far field would incorrectly store the data as a far field stored data result.
- Updated the parameter sweep script to ignore results that are not available. This could be due to simulations that aborted or results that did not converge. A message is displayed with a list of the runs that are excluded from the combined results.
- Updated the **Parameter sweep: Combine results** application macro to support Cartesian boundary near field results with a single surface. The script ignores merging data for Cartesian boundary near fields with multiple surfaces or any other faulty requests.

Solver

Resolved Issues

- Improved the robustness of ray/geometry intersection tests, during an RL-GO solution, to prevent corner cases where rays penetrated closed conducting surfaces.
- Fixed a bug that triggered a floating point exception when computing the transfer impedance of Demoulin/Tyni shield with minimum optical coverage set to 100%.
- Added support for current sources on FEM line ports within an anisotropic FEM region.
- Improved the time efficiency of the computation of interactions in free space during the right hand side calculation phase of the solution for models with impressed current sources.
- Refined the accuracy settings for calculating the per-unit-length parameters of unshielded cable bundles.
- A short-circuit connection is now allowed between a subset of pins of a black box circuit or a general non-radiating network that has more than two exposed pins, that is connected to a cable.
- Fixed a bug that resulted in large reflection coefficients being computed for models with lossy multilayer substrates solved with RL-GO.

- Improved the accuracy of source power calculations for models with impressed near field sources.
- A warning is now issued when compression of plane waves, in a loop with multiple directions of incidence, is not applicable and a phase corrected initial guess is applied during the iterative solution when reverting to the solution with each plane wave in the loop as excitation.
- Fixed a bug that led to an error state when solving a combined MoM/MTL cable harness with a double shield.
- Fixed a bug that could have resulted in a message passing interface (MPI) buffer overflow.

Shared Interface Changes

Features

- Added an additional POSTFEKO extraction script to the Feko-HyperStudy interface. If a POSTFEKO session is available in the study folder (without an extraction script), the new extraction script is created in the folder when importing variables in HyperStudy. The script extracts all the visible traces on the Cartesian and polar graphs in the session to the HyperStudy output file. The HyperStudy output file can then be accessed in HyperStudy to set up an output response to be used in a DOE or optimisation run.
- Added a tree widget for Lua forms. The **FormTree** object is available in the CADFEKO and POSTFEKO API.

Resolved Issue

- Resolved an issue with the HyperStudy-Feko utility where the file dependency list was not populated correctly.

Support Components

Features

- Reduced the licence checkout times for some components.
- Updated the response surface-based optimiser to the latest version.

Resolved Issue

- Fixed a bug that led to a crash in OPTFEKO on Windows.

WinProp 2019.2.1 Release Notes

The most notable extensions and improvements to WinProp are listed by component.

General

Feature

- Changes made to the `.net` file during optimisation with OptMan are now saved automatically. This avoids pop-up windows at every iteration.

Resolved Issue

- Improved error messages and warnings in OptMan. When an OptMan simulation is launched without an optimisation target, the error message will state what is missing. Further, some unnecessary warning messages were removed.

ProMan

Features

- The delay of the shortest path from transmitter to receiving point can now be computed and is available for display in the results tree.
- Added support for the 512-QAM and 1024-QAM modulation types.
- Improved the performance of the ProMan GUI when dealing with large databases. The response time of the GUI to various click events, as well as the loading time for displaying results in the 3D view, are reduced.
- Added support for the definition of a rotation angle that can be applied to rotate all receiving array elements in the azimuth plane, for the case when receiving antenna is defined using the **Individual location offset for each element** option.

Resolved Issues

- Fixed a bug that resulted in the effects of the direct ray not being taken into account during simulations with the intelligent ray tracing (IRT) model in urban scenarios.
- Fixed an issue where displaying a result for time-variant simulations in point mode, did not show colour in the result pixel.
- Fixed a bug that led to a corrupted visualisation of results in ProMan for a rural project with topography defined in geodesic coordinates.
- Fixed a bug in the interpolation of topographical elevations. This improved the accuracy of results in rural scenarios. Also, the topographical height at the location of the transmitter is now correctly computed.
- Improved the accuracy of predictions inside buildings in an urban scenario.

- Fixed a crash that could occur in a rural propagation simulation when Channel Impulse Response was requested as output while Propagation Paths were not requested.
- The east over north angular convention is now used in the spatial channel impulse response and angular profiles (MS, BTS).
- Fixed a bug that resulted in the wrong longitude being written to the `.kml` file when exporting prediction results, as a bitmap, to Google Earth.
- Improved the wedge detection algorithm to correctly handle wedges between a wall with disabled diffractions and one with enabled diffractions.
- The computation of angular means at the base and mobile stations is reactivated as a result type obtainable from propagation analysis.
- The option to select terrain vector databases in `.tdv` format is now available in the list of supported file formats under the menu **File > Open Database**.
- Rays can now be displayed for time-variant projects with a stationary simulation.
- New EMC specification files can now be created in ProMan.
- The input and output frame rates of a ProMan animation are now set to be equal. Previously, only the output frame rate was specified, and a constant value was used for the input frame rate. A mismatch in input/output frame rates could have resulted in some snapshots of the animation not being captured.
- Computation filter settings, specified under global settings, are now applied also to mobile-station (RunMS) results.
- Fixed a bug that resulted in the propagation path not being correctly displayed in 3D view for paths longer than 20 km.
- Fixed a bug that resulted in a misalignment between the computed results and the defined prediction area, for a rural scenario project with the topography defined in geodesic coordinates.
- Fixed a bug in the determination of line-of-sight pixels for projects consisting of a directive transmitter and solved with the dominant path model or as ray tracing models (SRT/IRT) when the contribution of the direct ray is disabled.
- Added support for the use of database files with multiple extensions when creating a new ProMan project.
- The interference between antenna components is now correctly considered only when the antennas are fed by different transmitters at the same carrier frequency. Previously, antenna components were treated as though they were fed by different transmitters, leading to incorrect interference results (low SNIR values).
- Translation and rotation of a receiver, along a trajectory, are now considered for power azimuth spectrum computations.
- The effects of the curvature of the earth is now more accurately considered in the deterministic and empirical two ray models in rural scenarios.
- Fixed a bug that not all transmitters were listed in the network planning ASCII result files.
- Improved ProMan's user-friendliness in case a user tries, by mistake, in a network planning project without a pre-defined air-interface file, to assign a carrier frequency to a transmitter before any carriers are defined. It used to be difficult to exit the particular dialog in that situation. Now the user is informed about what is missing and on which dialog the carriers can be defined.

- Fixed an issue that in a network planning project with components, depending on the air interface, some results could not be displayed.
- Fixed a display bug in the 3D view that resulted in an offset in the elevation profile of the displayed results of a tunnel being introduced when disabling topography from the display settings.
- While rural ray tracing is supposed to include interactions with the terrain only in the vertical plane, it used to find and use wedges in the terrain everywhere. This incorrect behaviour, which could increase the simulation time dramatically, is corrected. For 3D interactions with terrain, other simulation methods remain available.
- Fixed a bug where the ProMan project icon (top left, next to the **File** menu) had incorrect options and could sometimes make ProMan crash.

WallMan

Feature

- Added support for digital terrain elevation data in the `.dt3` format.

Resolved Issue

- Saving building shapes for an imported indoor database can take significant time while it is only necessary when preparing a hybrid urban/indoor scenario. Therefore, it is now disabled by default. This option can be activated on the **File > Save Database As** dialog.

AMan

Resolved Issue

- Fixed a bug that resulted in a crash when combining antenna patterns with the multiple antenna configuration feature in AMan.

Application Programming Interface

Features

- Added support for in-model parallelisation in the WinProp API for propagation predictions, network planning as well as database preprocessing.
- Added examples demonstrating multi-threading with the WinProp API.
- Added an example demonstrating urban database preprocessing using the WinProp API.

Resolved Issues

- Updated the path of the input directory in the distributed WinProp API usage examples.
- The database conversion function, `WinProp_Convert`, now converts indoor databases to the `.idb` binary format by default.

- Error codes returned by the functions of the WinProp API now match the description given in the reference documentation.
- Specific error messages are now returned from the WinProp API in Linux in cases where a generic `Unknown error` was issued before.

Altair Feko 2019.2 is available with a long list of new features, corrections and improvements. It can be applied as an upgrade to an existing 2019 installation, or it can be installed without first installing Altair Feko 2019.

This chapter covers the following:

- [Highlights of the 2019.2 Release](#) (p. 331)
- [Feko 2019.2 Release Notes](#) (p. 335)
- [WinProp 2019.2 Release Notes](#) (p. 340)

Feko is a powerful and comprehensive 3D simulation package intended for the analysis of a wide range of electromagnetic radiation and scattering problems. Applications include antenna design, antenna placement, microstrip antennas and circuits, dielectric media, scattering analysis, electromagnetic compatibility studies including cable harness modelling and many more.

WinProp is the most complete suite of tools in the domain of wireless propagation and radio network planning. With applications ranging from satellite to terrestrial, from rural via urban to indoor radio links, WinProp's innovative wave propagation models combine accuracy with short computation times.

Highlights of the 2019.2 Release

The most notable extensions to Feko and WinProp in the 2019.2 release.

Salient Features in Feko

- Significant improvements are included in the 2019.2 release that bring about better performance and a reduction in memory requirements for multiple solution methods. The multilevel fast multipole method (MLFMM) solution method boasts matrix fill times that are three or more times faster by utilising an efficient matrix fill strategy. The parallel scaling of the MLFMM is improved through reduced communication between processes, with the effect becoming more pronounced as the number of processes increase. Aperture to spherical mode source transformation is available for the MLFMM solution method. The time required to calculate the excitation vector is significantly reduced when the transformation can be applied. Total run time reductions of 30% to 50% were observed for example models. In addition to the improved performance, the fast far field calculation (employed for the MLFMM and other solution methods) uses 30% less memory than before. Optimisation of the adaptive cross-approximation (ACA) matrix fill stage provides a factor two improvement in performance. The ray launching geometrical optics (RL-GO) solution method now utilises shared memory containers resulting in reduced memory requirements for parallel simulations. A change to the ray storage strategy that avoids duplication of information greatly reduces the size of the `.bof` output file and also improves the performance of the RL-GO when the option to store the rays for processing in POSTFEKO is enabled.
- Model decomposition is made easier with the new Cartesian boundary near field request. The request is defined by points on the surface of a cube (no points are calculated inside the cube volume) and the surface can then be used as an aperture source in subsequent models. The request also allows the user to exclude one or more of the surfaces where the field is known to be zero, such as on a PEC ground plane. The workflow is considerably simplified compared to defining the rectangular surfaces manually and then ensuring that all the surfaces are correctly positioned and oriented to form the aperture source.

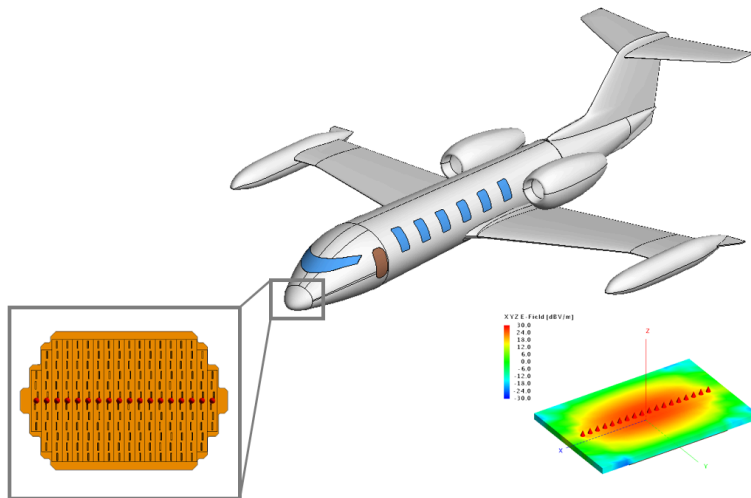

Figure 65: An example of a weather radar in an aircraft radome where the Cartesian boundary near field request can be used to simplify model decomposition.

- The finite element method (FEM) solution method is extended to allow transmission lines and non-radiating networks that connect to different FEM ports. Previously the networks could be defined on a single FEM port, but connecting different FEM ports together was not supported. Feed structures and filters (circuits) can now be connected to the FEM model. These complex FEM components can be used in a larger MLFMM model, improving the MLFMM convergence by encapsulating the complex component in the FEM region.

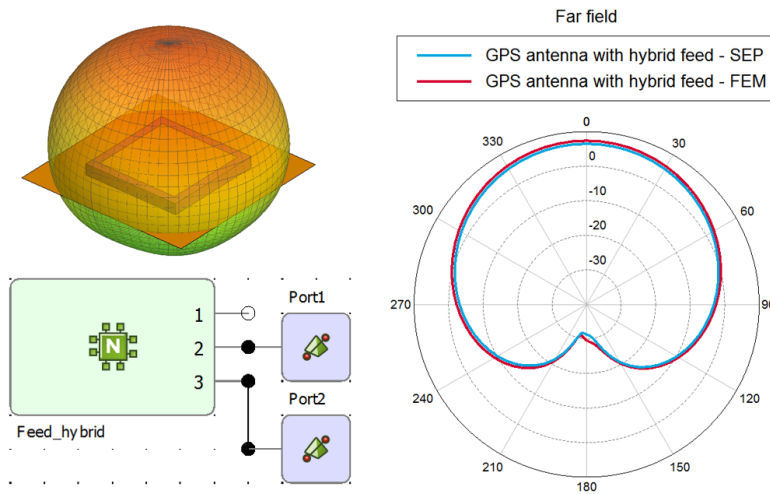

Figure 66: A GPS antenna with feed network solved with the MoM (SEP) and the FEM.

- Two new features are added to the Cartesian surface graph allowing better data representation and evaluation. The surface graph, similar to the 3D view display, interpolates between values to show continuous results as a smooth surface. A discrete display option is added for cases where continuous results are not applicable. When the aspect ratio of the X and Y axis is important, the aspect ratio can be locked to avoid distortion of the image.

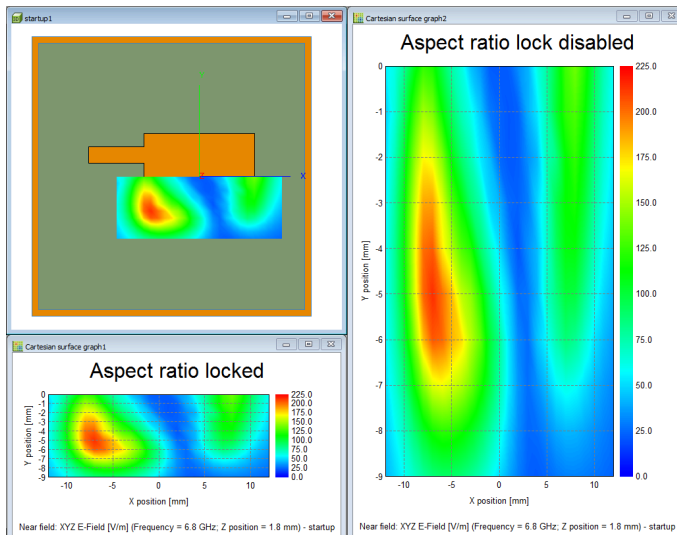

Figure 67: The aspect ratio of a surface graph can be locked.

- The voltage controlled voltage source (VCVS) and transformer components are introduced for the cable schematic editor. These components allow one-directional and bi-directional coupling of currents inside the cable shield to the outside of the cable shield to model the effects of imperfect cable terminations. It is crucial to model the cable terminations precisely to obtain accurate results. The cable solution is also extended with a circuit crosstalk calculation option that takes the geometry (installation) into account to determine the cable per-unit-length parameters, but does not include 3D field coupling between the harness and the installation. This option is useful when only the terminal voltages and currents are of interest and 3D field coupling effects can be disregarded.

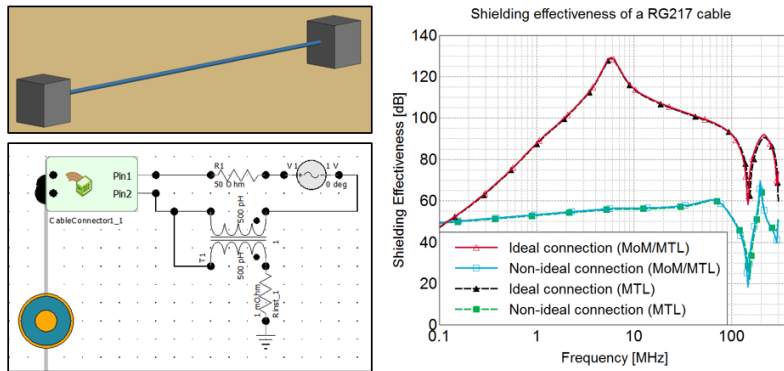

Figure 68: A non-ideal cable termination modelled using the new transformer component.

Salient Features in WinProp

- WinProp is enhanced with the ability to perform 5G network planning analysis. Dedicated 5G air interface files (wireless standard files) are shipped with the examples. When a new project is created with one of these files, the graphical user interface offers 5G options such as numerology, 5G carrier bandwidths, larger number of subcarriers, advanced transmission modes, which are then taken into account in the analysis.
- Support is added for predictions on a trajectory with varying heights for indoor and rural scenarios.

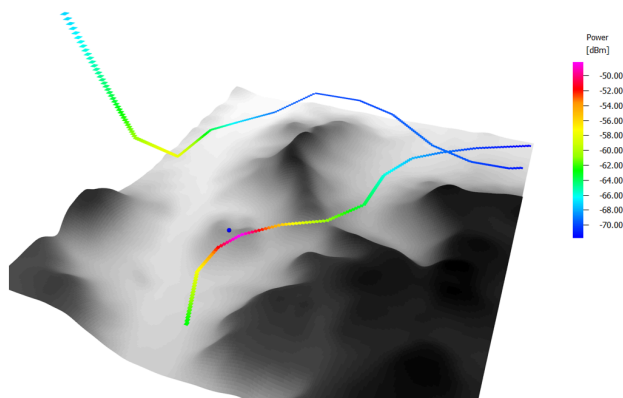

Figure 69: Trajectories are no longer limited to a fixed height above ground.

- The speed of propagation predictions is improved by accelerating the line-of-sight analysis between transmitter and receiving points, for different types of databases (vector, pixel, topography) and all scenarios (indoor, urban, rural). A speed-up factor of two times or more is achievable for the start-to-finish simulation for various propagation models. Furthermore, the accuracy is improved for different propagation models as more valid interaction points are obtained with the new implementation. The increased accuracy is especially apparent for problems involving topography or urban vector databases.
- Standard ray tracing (SRT) is accelerated through the use of more efficient algorithms. In combination with the faster line-of-sight checks, a speed-up of an order of magnitude is possible.

Feko 2019.2 Release Notes

The most notable extensions and improvements to Feko are listed by component.

CADFEKO

Features

- Extended cable modelling with the following:
 - Introduced voltage controlled voltage source (VCVS) and transformer components for cable schematics. These components can be added to cable terminations to define coupling between the inside and outside problems over a cable shield.
 - Added the **Circuit crosstalk** option to the **Solution** tab of the **Modify cable harness** dialog. This option enables the calculation of intra-cable coupling inside the cable harness.
 - Added the ability to increase the **Cable per-unit-length parameter accuracy** from **Normal (default)** to **High** or **Very high**. This setting is specified on the cable type definitions, for example, the **Create ribbon** dialog.
 - Coaxial cables using the **Specify cable characteristics** definition type are now specified by magnitude of characteristic impedance, attenuation and velocity of propagation. The phase of the characteristic impedance and real part of the propagation constant input fields are removed from the **Create coaxial cable** dialog.

The properties of cables using the deprecated definition will be converted to the new definition assuming a frequency of 1 kHz and the phase of the characteristic impedance is set to 0.

The API methods `AddCoaxialUsingCharacteristics` and `AddCoaxialUsingCharacteristicsWithCoating` have been deprecated and will trigger errors when used. Please update Lua scripts with `AddCoaxialUsingPropagationCharacteristics` and `AddCoaxialUsingPropagationCharacteristicsWithCoating`.

- Extended near field requests to support a Cartesian boundary definition method that allows specifying the field points on the bounding faces of a box.
- Upgraded the meshing library, bringing improvements such as the better handling of helical structures. The upgrade provides a fix for a meshing issue that could result in no mesh for a helical face or a mesh for a helical cutout instead of the geometry surrounding the cutout.
- Extended the CADFEKO API by adding the `ClosestVertexTo` method to the `MeshTetrahedra`, `MeshTriangles` and `MeshSegments` objects. This method can be used to obtain a mesh vertex located near a specified point.

Resolved Issues

- Fixed the problem that the Ctrl+Shift+A keyboard shortcut did not select all items belonging to the same part as a face, edge or region selected in the tree. Extended the Ctrl+Shift+A functionality to support selection in the 3D view for all selection types. In addition to faces, edges and regions, this shortcut can now also be used to select mesh labels, mesh elements and mesh vertices. The **Select all** and **Select all in part** options are available in the applicable 3D view and tree context menus.

- Resolved a problem where mesh wires were not highlighted in the 3D view when selecting an option applied to wires (such as **Windscreen solution elements**) on the **View by solution parameters** dialog.
- Fixed the colouring of cable shield media in the cable cross-section preview on the **Modify coaxial cable** dialog.
- Corrected the icons used for coaxial cables in the model tree. Before, the **Predefined coax** icon was displayed in the tree for **Specified coax** cables using the **Specify cable characteristics** definition type (instead the **Specified coax** icon).

EDITFEKO

Features

- Extended the **CI - Cable interconnection/termination definition** card to support voltage controlled voltage source (VCVS) and transformer components at cable terminations.
- Added the **Circuit crosstalk** option to the **CS - Define cable path section** card. This option enables the calculation of intra-cable coupling inside the cable harness.
- Extended the **CD - Cable cross section definition** card to allow for changing the **Cable per-unit-length parameter accuracy** from **Normal (default)** to **High** or **Very high**.
- Changed the **Coaxial cable characteristics** definition on the **CD - Cable cross section definition** card to use magnitude of characteristic impedance, attenuation and velocity of propagation. The phase of the characteristic impedance and real part of the propagation constant input fields are removed from the dialog.

When pressing F1 to modify an older CD card, an error message will be displayed, after which the properties will be converted to the new definition assuming a frequency of 1 kHz. The phase of the characteristic impedance is set to 0.

- Extended the **FE - Calculate the near fields** card to support Cartesian boundary near fields that allows defining a near field request as the bounding faces of a box.

POSTFEKO

Features

- Added the functionality to lock the aspect ratio of a Cartesian surface graph. The default **Auto lock aspect ratio** setting locks the aspect ratio of a surface graph in certain cases, for example, when both axes are set to a unit of distance. Aspect ratio locking can also be purposely enabled or disabled for a surface graph.
- Introduced a discrete, non-interpolated rendering option for results plotted on Cartesian surface graphs.
- Changed the 3D view display of RL-GO rays to show a single ray by default. Select the **All** checkbox above the list of rays on the result palette to display all rays.
- Added data rate (bit/s) as a unit that can be used when importing and scaling data.
- Added support for exporting stored transmission/reflection coefficient data to `.tr` file.

- The `.fek` file version is increased to 169 to accommodate new features.
- Added support for viewing probe results for voltage controlled voltage source (VCVS) and transformer components.
- Added the functionality to support the new near field type using the **Cartesian boundary** coordinate system.
- Added support for the import and export of `.efe` and `.hfe` files containing Cartesian boundary near field requests.

Resolved Issues

- Fixed an assertion that failed with the message that `Two ribbon tools are trying to use the same state widget (Greyscale) at the same time`. This could be encountered when clicking on the window tab to switch from a 2D graph to a 3D view after making a change to a trace on the 2D graph.
- Fixed a display issue with non-radiating networks and transmission lines that surfaced on certain port types when a scale factor was applied.
- Updated the ribbon to allow adding characteristic mode results to a Cartesian graph from the **Trace** tab.
- Updated the parameter sweep script to support combining data from finite antenna array models using the domain Green's function method (DGFM).

Solver

Features

- Added support for the computation of near field requests based on a Cartesian boundary definition method that allows specifying the field points on the faces of a cuboid.
- Added support for transformer and voltage controlled voltage source (VCVS) components to allow coupling between inner and outer problems, at the terminations, to be taken into account during analysis of a cable.
- Improved the performance of the combined MoM/MTL solution method for cases with multiple cable harnesses where radiation is considered.
- Added support for user-specified mesh settings of 2D cable cross sections. Three options with increasingly fine meshing and thus improved accuracy can be selected.
- Added support for the definition of coaxial cables based on attenuation and velocity of propagation. This replaces the propagation constant based coaxial cable definition in previous versions of Feko.
- Significantly improved the time-efficiency of the matrix fill stage of an MLFMM solution of a model using the EFIE, resulting in a significant reduction of the overall solution time.
- Improved the performance of an MLFMM solution by reducing inter-process communication when carrying out matrix-vector products with many parallel processes.
- Added support for equivalent source transformation when solving a model with impressed near field sources with MLFMM, resulting in a significant decrease of the time taken to evaluate the right-hand side vector, and a significant reduction of the overall solution time.

- Reduced memory requirements for far field calculations using the fast far field method for solutions other than MLFMM.
- Significantly improved the time-efficiency of the matrix fill stage of the ACA solution. A speed-up factor of about two times can be achieved for most cases.
- Significantly reduced the memory usage of parallel RL-GO simulations of models involving many requested field samples or many near field sources, through the use of shared memory.
- Significantly improved the performance of the ray export phase of an RL-GO solution of dielectric models on machines with the Windows operating system. Achieved a speed-up factor of about four times for dielectric models with a large number of rays.
- Significantly improved the time efficiency of the geometry checking phase of an RL-GO solution, with diffraction effects taken into account, of a problem with a large number of triangles. The scaling of the geometry checking phase, with respect to the number of triangles, is improved from linear to logarithmic scaling.
- Improved the matrix fill stage performance for large parallel MoM solutions.
- Added support for connecting FEM line ports with a non-radiating network.
- Changed the default preconditioner for FEM models to improve robustness of the solution as well as to obtain consistent behaviour between models solved sequentially and in parallel. Sparse LU-based preconditioners are now consistently selected by default, where ILU-based methods were sometimes used before. Additionally, a direct sparse solver is used, instead of an iterative solution, for first-order decoupled FEM models.
- Upgraded the MUMPS library used in the Feko kernel to version 5.2.1.
- Upgraded the default SPICE engine to HyperSpice Version 2019-33627.
- Upgraded the eigenvalue and eigenvector solution library to the latest version.
- The str2ascii tool is extended to support the latest `.str` file format (13).

Resolved Issues

- Fixed a bug that resulted in inconsistent results upon repeatedly running a diffraction enabled RL-GO model in parallel using shared memory.
- Fixed a bug that resulted in noisy monostatic RCS results when a model, meshed with curvilinear triangles, is solved using RL-GO with high convergence accuracy settings.
- Improved a noisy RCS response for some RL-GO models meshed with curvilinear triangles by improving the robustness of ray/curvilinear triangle intersection tests.
- Fixed a memory leak associated with far field requests in RL-GO models.
- Improved the robustness of continuous frequency sweep interpolation on real-valued quantities such as gain or power. Interpolation artefacts in the form of spurious peaks in the frequency response are no longer present. (ADAPTFEKO)
- Fixed a bug that resulted in incorrect port impedance values when re-using a `.str` file produced with Feko version 14.0.430-635, in a version later than Feko 2017.2.
- Fixed a bug that led to an error when calculating contributions from higher-order mode excitations in a coaxial waveguide port.
- Fixed a bug that resulted in the inability to visualise received power for subsequent receiving antennas in POSTFEKO, for cases where more than one receiving near field aperture, consisting of multiple faces, is defined within one configuration.

- Improved the parallel scaling of the “Calculation of matrix elements” stage of a MoM solution for some process grids. For instance, a simulation with 62 processes was previously a factor of about two times slower than one with 64 processes. This has now been fixed.
- Refined conditions under which a microstrip port may be used.

Shared Interface Changes

Features

- Upgraded the visualisation library used by CADFEKO and POSTFEKO.

Resolved Issues

- Resolved an issue with the graphics driver initialisation on Linux platforms. The driver was not set when selecting to use software rendering (instead of running the graphics test) when first launching CADFEKO or POSTFEKO after installation.
- Fixed the application menu help links and the start page links to documentation and videos for client installations.

Support Components

Features

- Added the WinProp Getting Started Guide and WinProp Scripting and API Reference Guide to the Launcher.
- Added an example of how to define a time domain pulse mathematically using analytical functions in POSTFEKO to the Feko User Guide.
- Corrected the Feko User Guide to indicate that vias are added as wires between layers for ODB++ and 3Di file imports only. A single PCB layer is imported from a Gerber file. Vias are not supported for Gerber format.

Resolved Issue

- Resolved the issue that an incorrect proxy configuration could cause the Updater to hang. Pressing **Cancel** now takes effect, allowing the user to correct the proxy settings.

WinProp 2019.2 Release Notes

The most notable extensions and improvements to WinProp are listed by component.

General

Features

- Added an envelope pattern file, for 5G applications, to the set of examples in the help directory.
- An updated and unified WinProp Scripting and API Reference Guide is now available in PDF and as part of the HTML documentation.
- A WinProp Getting Started Guide is now available. The following examples were added:
 1. Analyse a Wi-Fi router in a building.
 2. Analyse the indoor cell phone reception, set in an urban environment.
 3. Analyse base stations in a city, set in an urban environment.

Resolved Issue

- Fixed a problem whereby OptMan and CoMan did not return Hosted HyperWorks Units automatically when closed. (Note: The problem was limited to Hosted HWU).

ProMan

Features

- Enhanced WinProp with the ability to perform 5G network planning analysis. Dedicated 5G air interface files (wireless standard files) are shipped with the examples. When a new project is created with one of these files, the graphical user interface offers 5G options such as numerology, 5G carrier bandwidths, larger number of subcarriers, advanced transmission modes, which are then taken into account in the analysis.
- Modern 5G systems may utilize antenna beam forming at the base station to increase the antenna gain in the direction of a mobile station. WinProp offers users the option to specify beam forming gains for the serving cell and for the interfering cell, for the data channel and for the control channel. This simplifies the workflow by not having to specify all the detailed patterns and mobile station locations.
- Introduced the concept of "Envelope Antenna Pattern" to account for beam switching at the base station in 5G. The base station can be equipped with antenna arrays and with digital logic to generate the best beam to reach the user equipment. The envelope pattern is based on the collection of possible antenna beams at the base station. In this release, one envelope pattern is used for both Control and Data. For the next release, separate envelope patterns for Control and Data are scheduled to be implemented.
- The amount of overlap between sub-carriers of interfering cells can now be specified for LTE and 5G air interfaces.

- Accelerated standard ray tracing (SRT) through the use of more efficient algorithms. In combination with the faster line-of-sight checks, a speed-up of an order of magnitude is possible.
- Improved the speed of propagation predictions by accelerating the line-of-sight analysis between transmitter and receiving points, for different types of databases (vector, pixel, topography) and all scenarios (indoor, urban, rural). A speed-up factor of two times or more is achievable for the start-to-finish simulation for various propagation models. Furthermore, the accuracy is improved for different propagation models as more valid interaction points are obtained with the new implementation. The increased accuracy is especially apparent for problems involving topography or urban vector databases.
- Added support for predictions on a trajectory with varying heights for indoor and rural scenarios.
- The prediction height in point and trajectory modes can now be specified relative to floors (only for indoor scenarios), ground or sea level. This is also applicable for preprocessed databases.
- Added support for predictions based on an absolute height (as opposed to a height defined relative to the topology as before) for rural scenarios with all prediction models.
- Similar to rural and urban scenarios with topography, one can now specify heights in indoor scenarios with topography in more than one way: height above ground (or floor) or height above sea level.
- Added support for absolute prediction height definitions (specifically absolute height above sea level) for all propagation models in urban scenarios.
- Results along a trajectory and results in time variant projects, including ray interactions with surrounding buildings, can now be animated in the 3D view. The animation and snapshots thereof can be exported and saved to a video file and bitmaps, respectively.
- The phase of the antenna pattern at both the base and mobile stations is now considered when computing the overall contribution of rays at receiving point.
- The yaw, pitch and roll angles can now be specified when computing received power (and associated quantities) along a 3D trajectory.
- Increased the maximum number of reflections supported by the IRT propagation model from 6 to 20.
- Added an option to ignore the effects of the direct ray from transmitter to receiver for SRT and IRT indoor scenarios.
- Result plots with rays can now be animated in projects with time variance or with virtual drive tests.
- The position of the antenna can now be specified with sub-millimetre accuracy, up to a tenth of a millimetre.
- Improved the accuracy of channel capacity and channel condition number.
- Enhanced the rural ray tracing (RRT) computational method with knife-edge diffraction. Rural ray tracing has a limit to the number of interactions and could leave some locations without prediction. Knife-edge diffraction adds the necessary interactions to end up with predictions for the entire area of interest.
- The transmission matrix associated with each ray is now also written to the `.str` file exported during post-processing with RunMS. Additionally, information regarding the phase of each ray as well as Doppler shift is now also written to the `.str` file.

- Direction of arrival and direction of departure angles are now written, in radians, to the `.str` file for each computed path. Additionally, these values are also displayed in the ProMan GUI when visualising rays.
- The phase of the field strength is now written to the `.str` file for each computed path. Additionally, these values are also displayed in the ProMan GUI when visualising rays.
- For rural/suburban scenarios, a parabolic equation solution method is available.
- Improved the computation of interactions during standard ray tracing when an object is replaced by RCS data, to consider additional interactions after scattering. This leads to an increased number of paths from transmitter to the RCS object, resulting in improved delay spread calculation.
- RCS data associated with an object can now be plotted in ProMan.
- Added a GUI option to run all computations defined in a project, one after the other. The computation sequence is as follows: propagation (RunPRO), Mobile station post-processing (RunMS), network planning (RunNET).
- Improved importing measurement data into ProMan to consider the average value of multiple measurements at the same coordinate. Previously, the final measurement for a specific point was used.
- Modified indoor database preprocessing for IRT in point mode to be independent of a defined receiving point at preprocessing time. This improvement allows one to simulate different receiving points without the need to preprocess the database for each new point.
- The inclusion of topography from a pixel database in "indoor" scenarios has been enabled. This is a first step; rays in ray tracing models do not yet interact with the topography.

Resolved Issues

- Fixed a memory leak in SRT computations with scattering enabled.
- Fixed a bug that resulted in a simulation error, with a preprocessed database, when the selected prediction area is larger than the defined area during IRT preprocessing.
- Fixed a bug where computed results were not invalidated, in ProMan, upon changing the prediction model.
- Improved the functionality to import a transmitter from `.csv` file to automatically map imported quantities to valid ProMan properties. With this improvement, the order of imported items is no longer relevant, and it is now possible to import all or a subset of the quantities defined in the `.csv` file.
- Fixed a bug that resulted in some transmitters, for a project with multiple transmitters, not being displayed when viewing network planning results in a new window. Additionally, the mismatch in the name and orientation of the displayed subset of transmitters has also been fixed.
- Fixed a bug that resulted in an error during propagation modelling or post-processing due to a very small resolution being defined for point mode results. The point-mode resolution is now limited to a minimum of 2 cm. Note that point-mode resolution is only related to the size of the pixel displayed when loading results and larger resolutions are typically better for visualisation. The location of the point itself can be specified to sub-millimetre accuracy.
- Fixed a bug that resulted in the computed per stream received power being lower than the corresponding sub-channel power results for a few points along a trajectory, when the receiver at the mobile station consists of more than one antenna element.

- Fixed a bug that led to ray data not being saved in the `.str` file resulting in a crash in ProMan when attempting to display the aforementioned rays.
- Fixed a bug that resulted in a crash when viewing results and toggling between 2D and 3D view.
- Fixed a bug that could cause ProMan to crash when adding a cable from a Component catalog before other components were present.
- Fixed a crash in RunMS that could occur when computing the "stream" results.
- Fixed an occasional crash that could occur during RunMS in a rural project with topography.
- Fixed a bug in the consideration of diffraction effects, for multiple interaction points associated with a ray, during standard ray tracing.
- Fixed a bug that resulted in trajectory results always being computed at a default height of 1.5 metres, rather than the defined height of the trajectory. Such behaviour was present if one switched from area-wide simulation, with the prediction area defined as "Individual for each transmitter", to trajectory mode.
- Improved the robustness and accuracy of predictions made with the COST Walfisch-Ikegami model by improving the method used to determine building attributes (for example, width and height). Predictions are now more accurate and especially robust in cases where the database has some defects such as a building being defined twice or a building with zero height. These defects are typically present in imported databases from various open source repositories.
- Fixed a bug that led to discontinuities in results obtained for indoor predictions based on a user-defined variable attenuation.
- Fixed a bug that could make Doppler shifts oscillate rapidly along a trajectory.
- Fixed a bug that resulted in computed pixels not being located along the defined trajectory, when the IRT propagation model is used.
- Depending on the user-defined boundaries of the prediction area, the underlying topography in a rural scenario could be shifted by up to half of the prediction discretisation. This is fixed.
- Keysight PROPSIM channel output is now given based on relative delays, with the first value starting at 0.
- Fixed a bug that resulted in offset of individual antenna elements, relative to the centre of the mobile station, not being correctly considered for the case of a varying directional vector along a trajectory. This is only applicable for the post-processing option with "Individual location offset for each element" specified as the type of receiving antenna.
- WinProp is now more tolerant of small format variations in `.ffe` files.
- Fixed a bug that resulted in the computed exclusion zones not being correlated to the population threshold defined in the EMC specifications.
- In Monte-Carlo analysis, the calculations of the Tx power load and the uplink noise rise are now more accurate.
- Improved the results display of a Monte-Carlo analysis. All categories of users are shown, and selected results are presented in terms of number of users rather than Erl/km².
- Fixed a bug where the **Monte-Carlo Analysis** dialog for **Traffic Definition** could sometimes show the unit Erlang/m² while the user had elected to work in Erlang/km².
- Fixed a bug that resulted in vector buildings specified at an absolute height relative to sea level, being incorrectly displayed as relative to ground in 3D view.

- Fixed a bug that resulted in predictions of rural results on a defined absolute height above sea level being incorrectly displayed with a height relative to topography in 3D view.
- Fixed a bug that resulted in the height of prediction plane and point mode results not being scaled along with a scaling applied to topography in 3D view.
- Fixed a bug that resulted in a constant height being used during the computation of over-the-rooftop loss for an urban signal path with varying distance from the rooftops. The actual height of the path at every point is now used.
- Fixed a bug in the consideration of the azimuth rotation angle applied to an array of receiving elements at a mobile station when the post-processing option including Tx and Rx is used.
- Fixed a bug that resulted in topography not being correctly displayed in 3D view for very large areas.
- Fixed a bug that led to the incorrect detection of the edges of topography data defined in geodesic coordinates, resulting in an error during simulation.
- Fixed a bug when computing the transmission loss based on an empirical loss model. This affects cases where duplicate walls are present in a database as well as special cases where two transmission interaction points are collocated.
- Fixed a bug that resulted in a non-smooth variation of results in 3D view when there is a large difference between the resolution of the topography and that of the predictions for urban scenarios.
- Fixed a bug caused by the gain of a transmitter, imported from a `.csv` file, being set to a different value prior to network planning. This resulted in an error due to the mismatch between the gain used for propagation and network planning analyses.
- Fixed a bug that resulted in some predictions, such as the minimum number of interactions or the line of sight, not being computed for some rural scenarios involving clutter data.
- Fixed a bug that resulted in an error when subtracting point-mode results with the option **Value (File, delog., incoherent)**.
- Log files of the post-processing stage with RunMS are now written in the specified output directory. These were previously written to a "PropName" directory.

WallMan

Features

- Enhanced the zoom capability in WallMan to enable zooming in on small geometry details.
- Modified indoor database preprocessing for IRT in point mode to be independent of a defined receiving point at preprocessing time. This improvement allows one to simulate different receiving points without the need to preprocess the database for each new point.

AMan

Resolved Issues

- WinProp is now more tolerant of small format variations in `.ffe` files.

- Fixed a bug whereby antenna pattern files with `.pln` file extension could be selected in AMan but the contents could not be read.

Application Programming Interface

Features

- Added support for network planning with a 5G air interface in the WinProp API.
- Added sample projects demonstrating the use of API for database preprocessing, database conversion, network planning and propagation modelling.

Release Notes: Altair Feko 2019.1.1

Altair Feko 2019.1.1 is available with new features, corrections and improvements. This version (2019.1.1) is a patch release that should be applied to an existing 2019 installation.

This chapter covers the following:

- [Feko 2019.1.1 Release Notes](#) (p. 347)
- [WinProp 2019.1.1 Release Notes](#) (p. 349)

Feko is a powerful and comprehensive 3D simulation package intended for the analysis of a wide range of electromagnetic radiation and scattering problems. Applications include antenna design, antenna placement, microstrip antennas and circuits, dielectric media, scattering analysis, electromagnetic compatibility studies including cable harness modelling and many more.

WinProp is the most complete suite of tools in the domain of wireless propagation and radio network planning. With applications ranging from satellite to terrestrial, from rural via urban to indoor radio links, WinProp's innovative wave propagation models combine accuracy with short computation times.

Feko 2019.1.1 Release Notes

The most notable improvements to Feko are listed by component.

CADFEKO

Feature

- Added the **Scale to metre** option when exporting a mesh to a unitless mesh format such as NASTRAN. When this check box is selected, the model unit is taken into account during export and the dimensions are written out in metre. Otherwise, the exported dimensions are in the model unit.

Resolved Issues

- Resolved a problem (that was introduced in the recent Feko 2019.0.1 update) where media cannot be assigned to windscreen solution elements.
- Resolved an issue with dialog focus when using the keyboard shortcuts to launch the Feko solver (Alt+4) or PREFEKO (Alt+2) while the model contains unmeshed parts. The **Unmeshed geometry** or **Inconsistent mesh** dialogs lost focus behind the application.
- Resolved a problem where mesh elements were written out twice to `.cfm` or `.fhm` file when not only exporting the current selection.
- Improved the options available for export when all meshes in a model are excluded. Some export options were incorrectly enabled before, leading to confusion about whether the excluded meshes would be exported. Excluded meshes are not exported.
- Resolved an issue with macro recording where the recorded script sometimes contained an invalid mesh ID for exporting a mesh.
- Resolved the problem that clicking on a link to an item in the message window or in the CEM validate dialog could cause an assertion failing with the message `Assertion failed: hasHandler.`
- Resolved an issue with the names "x", "y", or "z" used for points. If the model contained a reference to the component with the same name as the named point ("x.x", "y.y" or "z.z"), performing further steps could cause the application to close. The model could get into such a problematic state by importing a `.cfx` file. Renaming the referenced point caused an assertion failing with the message `Assertion failed: pVariable->isPoint() || pVariable->isScalar() || pVariable->isComplex()` and saving the model led to an assertion failing with the message `Assertion failed: isValid()`.

EDITFEKO

Resolved Issue

- Resolved a problem (present only in versions of Feko 2019) where the UT card panel was missing the **Normal side** and **Opposite to normal side** drop-down lists for setting the face absorbing properties.

POSTFEKO

Resolved Issue

- Corrected validation for the annotation position and result offset fields to use the Feko convention of the period as decimal symbol. Decimal values could not be entered on the **Configure annotation** dialog if the **Decimal symbol** specified in the operating system region settings was set to a character other than ".".

Solver

Resolved Issues

- Fixed a bug that resulted in high cross-polarisation levels when diffraction effects are included in the RL-GO solution of a model that is meshed with curvilinear triangles.
- Fixed a bug that prevented the application of the fast far field calculation method for a dielectric model (where diffraction effects are not supported) solved with RL-GO with diffractions enabled.
- Fixed a bug caused by Huygens sources not being created for incident rays that are not reflected from dielectric surfaces, resulting in improved accuracy in the calculated radiated power for such models.
- Fixed a bug that led to an error being issued during the geometry checking phase of the solution of a finite array model excited with a vertex port.
- The FEM line port load and non-radiating network implementation is improved, leading to more accurate results and improved power balance in some models (for other models the effect is negligible).
- Warning messages, about duplicate input files, are no longer issued during the import of CST near field scans when the model is located in the same directory as the near field data.
- Fixed a bug that resulted in an underestimate of the required memory for far field calculations, using the fast far field method, being reported in the `.out` file.

Shared Interface Changes

Resolved Issue

- Resolved an issue with the restored window size after opening the application if it had been maximised previously.

WinProp 2019.1.1 Release Notes

The most notable improvements to WinProp are listed by component.

ProMan

Resolved Issue

- Fixed a bug that resulted in an error while reading clutter data during a Monte Carlo analysis in an indoor scenario.

WallMan

Resolved Issue

- Fixed a bug that prevented the definition of floor levels in an urban database. As a result, clutter definition in an urban database is now possible.

Altair Feko 2019.1 is available with new features, corrections and improvements. It can be applied as an upgrade to an existing 2019 installation, or it can be installed without first installing Altair Feko 2019.

This chapter covers the following:

- [Feko 2019.1 Release Notes](#) (p. 351)
- [WinProp 2019.1 Release Notes](#) (p. 353)

Feko is a powerful and comprehensive 3D simulation package intended for the analysis of a wide range of electromagnetic radiation and scattering problems. Applications include antenna design, antenna placement, microstrip antennas and circuits, dielectric media, scattering analysis, electromagnetic compatibility studies including cable harness modelling and many more.

WinProp is the most complete suite of tools in the domain of wireless propagation and radio network planning. With applications ranging from satellite to terrestrial, from rural via urban to indoor radio links, WinProp's innovative wave propagation models combine accuracy with short computation times.

Feko 2019.1 Release Notes

The most notable extensions and improvements to Feko are listed by component.

CADFEKO

Resolved Issues

- Corrected the workplane handling of far field requests calculated in the plane wave incident direction to use the workplane settings from the associated plane wave source.
- Fixed a display issue with plane wave sources. A plane wave source defined to be looped over multiple directions, but defined with a single angle, was not displayed in the 3D view. Such a source is now rendered like its **Single incident wave** equivalent.
- Improved the robustness of the **Repair edges** tool.
- Updated the geometry exporter to Gerber format to use commands from the current Extended Gerber (RS-274X) specification. Deprecated commands are discontinued.
- Resolved an issue with PCB imports (Gerber and ODB++ files) that caused the imported geometry to be scaled by the model extents setting.
- Updated the parameter sweep script to support UNC paths for model files located on a network drive.

POSTFEKO

Feature

- Extended the POSTFEKO API with the `GetDataSet` method for `FarFieldPowerIntegrals` and `FarFieldPowerIntegralStoredData` objects.

Resolved Issues

- Fixed a regression introduced in POSTFEKO 2019.0.1 that could cause the result palette to remain active after creating a new project. Interacting with the trace (from the previous project) could cause the application to crash.
- Fixed an issue where legend scaling was not applied correctly when the legends were set to use **Scale only to selected frequency**. The legend range sometimes changed instead of remaining constant over frequency.
- Added validation to prevent calculating the inverse of a matrix containing invalid (NaN) values, which caused the application to close with a critical error. Running a script that calls the `Inverse` function on an invalid `Matrix` object will end in the error "Matrix inverse calculation failed."

Solver

Resolved Issues

- Improved the robustness of the ACA solution by improving the detection of linearly independent rows. This results in accuracy improvements without affecting performance.
- Fixed a numerical tolerance bug that led to incorrect S-parameter results for some models with a specific frequency sampling rate in a narrow band.
- Fixed a bug in the initialisation of the iterative solution of a decoupled FEM/MLFMM model. The fix enhances the accuracy of the iterative solution to match results given by a direct decoupled FEM/MoM solution.
- Improved the accuracy of the calculated per-unit length inductance/capacitance of cables, by refining the local mesh settings of a cable cross section.
- Parallel ordering is no longer activated by default, based on problem size, for MLFMM problems solved with a sparse LU preconditioner.
- Fixed a bug when calculating the percentage progress during the “Precomputation of far field coefficients” phase of the solution of a model with impressed sources. A percentage progress larger than 100% was previously displayed during this phase.
- Fixed a bug that prevented the use of radiating cable sources (CableMod/CRIPTE excitation) in a model solved with RL-GO.

Shared Interface Changes

Feature

- Added an option to the **Rendering options** dialog in CADFEKO and POSTFEKO to change the graphics driver. This option may provide a solution or workaround when experiencing graphics card problems.

Resolved Issues

- Resolved an issue with the keytips not being populated properly on the ribbon for the various GUI applications.
- Improved form dialog destruct behaviour. Hovering over the script editor in the Windows 10 taskbar (when the Windows system performance setting “Enable peek” is active) now only shows the dialogs from the script that was last executed. Before, the form dialogs from multiple scripts would be stacked in the preview.

WinProp 2019.1 Release Notes

The most notable extensions and improvements to WinProp are listed by component.

ProMan

Features

- For automotive radar applications, when radar cross section (RCS) information from Feko is used, this information is dynamically adjusted to account for the actual finite distance to the object.
- Added support for converting multiple topography tiles, given in the ASCII grid format, in one run. This is available through the **ASCII grid format index file (*.txt)** option in the topography conversion dialog box.
- The offset of receiver antenna elements is now considered in the delay calculations of subchannel and stream results.

Resolved Issues

- Attenuation due to atmospheric conditions was incorrectly considered for indoor and urban scenarios, and it was ignored for various propagation models in the rural scenario. This is fixed.
- Fixed a bug that resulted in wrong entries of the transmission matrix and the ex_v , ey_v , ez_v and ex_h , ey_h , ez_h values in case of non full polarimetric projects. In case of vertical polarisation at the transmitter the horizontal components of the transmission matrix were equal to zero. Non-zero entries are now computed for all polarisations.
- Fixed a bug that could cause the received power to be incorrect for a receiving antenna that was tilted close to 90 degrees up or down.
- Fixed a bug that resulted in the sub-channel power results written to ASCII files, during post-processing, being identical for multiple antenna elements at the receiver.
- Fixed a bug that resulted in a region of a rural database not being computed when an antenna pattern with a 0.25 degree resolution is used.
- Added support for patterns with sub one degree resolution at the mobile station.
- Fixed a bug that resulted in some of the network planning results along trajectory not being computed.
- Adjusted allowed tolerances to allow for network planning to be carried out with very fine resolutions.

WallMan

Resolved Issues

- Fixed a bug that resulted in visibility information from diffraction wedges not being included in an indoor database that is preprocessed for IRT.

- A check for a defined polygon has been added prior to preprocessing a database when the area of preprocessing is chosen to be based on a user defined polygon. An explicit error message is now issued prior to preprocessing in case there is no predefined polygon.
- Significantly reduced the time taken for database preprocessing for Urban IRT. A speed-up factor of ~2x can be obtained.

Release Notes: Altair Feko 2019.0.1

45

Altair Feko 2019.0.1 is available with new features, corrections and improvements. This version (2019.0.1) is a patch release that should be applied to an existing 2019 installation.

This chapter covers the following:

- [Feko 2019.0.1 Release Notes](#) (p. 356)
- [WinProp 2019.0.1 Release Notes](#) (p. 359)

Feko is a powerful and comprehensive 3D simulation package intended for the analysis of a wide range of electromagnetic radiation and scattering problems. Applications include antenna design, antenna placement, microstrip antennas and circuits, dielectric media, scattering analysis, electromagnetic compatibility studies including cable harness modelling and many more.

WinProp is the most complete suite of tools in the domain of wireless propagation and radio network planning. With applications ranging from satellite to terrestrial, from rural via urban to indoor radio links, WinProp's innovative wave propagation models combine accuracy with short computation times.

Feko 2019.0.1 Release Notes

The most notable extensions and improvements to Feko are listed by component.

CADFEKO

Feature

- Allow the use of metallic media for the ground plane option **Homogeneous half space in region Z<0 (reflection coefficient approximation)**. Validation prevents setting a metal as the ground medium when using the Sommerfeld formulation.

Resolved Issues

- The **Import geometry** dialog detects ODB++ files with the extension `.tar.gz`. In older versions it was required to change the drop-down list selection from **Unknown** to **ODB++** before files with this extension could be imported.
- Upgraded the ODB++ library to support layer thickness when importing geometry.
- Resolved an issue where Parasolid error P555 was encountered when importing a `.igs` file into an existing CADFEKO model.
- Added validation to the **Face properties** dialog to prevent the specification of incorrect material for a windscreen reference face. CEM validate detects windscreen reference faces in existing models where the face medium is set to a setting other than **Default** or **PEC**.
- Resolved an assertion that failed with message ending in `expressionValid`. The assertion failed when meshing and saving a model after using the API to first add an S-parameter request with a single waveguide port and then modifying the request using `SetProperties` to include more ports.
- Resolved an issue on the **Import mesh** dialog that caused the wrong type of files to be listed when browsing for files after selecting **CADFEKO mesh** or **Voxel mesh** as the file format. Selecting **CADFEKO mesh** format now correctly results in `.cfm` files being listed, and selecting **Voxel mesh** format shows `.raw` files.

POSTFEKO

Resolved Issues

- Resolved the issue that unit scaling was not applied to imported electric and magnetic field data.
- FFE file imports now support header fields in any order of appearance and white space delimiters consisting of spaces, tabs or a combination of both.
- Resolved an issue where an insufficient overlap warning was shown incorrectly for certain time analysis simulation frequency ranges.
- Resolved an issue where the application could not be closed after running a script that terminated with an error.

Solver

Features

- Added support for diffraction effects from edges and wedges of RL-GO PEC faces meshed with curvilinear triangles.
- Significantly improved the time efficiency of the geometry processing stage of the solution for FEM/MoM models.
- The definition of metallic materials is now allowed for the ground plane option **Homogeneous half space in region $Z < 0$ (reflection coefficient approximation)**.
- Improved the time efficiency of the solution by allowing the re-use of previously computed currents in a `.str` file for different power scaling applied to a model. Recalculation of the surface currents is avoided if a different source power scaling is applied to the model.

Resolved Issues

- Fixed a bug that resulted in the visibility of some wedges or edges to be incorrectly identified when the model is illuminated by a point source or a plane wave. This led to inaccurate results when computing diffraction contributions from the misidentified wedges with RL-GO.
- Fixed a bug that resulted in some rays, interacting with some RL-GO surfaces meshed with curvilinear triangles, being incorrectly traced.
- Refined the information about ray interactions with geometry written in the "RL-GO Engine Statistics" section of the `.out` file.
- Corrected the information in the header of exported `.ray` files to reflect that the exported field quantities are based on the magnetic field.
- Fixed a bug that resulted in the inability to visualise computed fields and received power of a model with receiving near field apertures in POSTFEKO.
- Fixed a bug that resulted in an internal error for a single wire model with one-dimensional periodic boundary conditions (PBC) where the wire is perpendicular to the vector defining the orientation of the PBC.
- Fixed a bug where a warning regarding singular fields was wrongly issued during far field calculations of a model involving a homogeneous ground space modelled with exact Sommerfeld integrals. This warning is no longer produced.
- Fixed a bug that resulted in incorrect computation of diffraction coefficients when a PEC RL-GO surface is embedded in a dielectric background medium.
- Monostatic RCS is now calculated using the phase offset of the incident plane wave rather than the offset specified at the coordinate axis of the far field request.
- Updated the warning message concerning the thickness of a coating layer applied to a segment to include cable specific details if the coating is indeed applied to the shield of a cable.
- Fixed a bug that resulted in a time increase of the phase of the solution during which the right hand side vector is calculated for some models with many impressed sources.

Shared Interface Changes

Feature

- Added a command line option (`--file-info`) that queries the application versions that were used to modify CADFEKO models and POSTFEKO session files.

Support Components

Resolved Issue

- Resolved an issue with the keytips of the Feko Launcher where the launch commands for other components took precedence over the keytip actions.

WinProp 2019.0.1 Release Notes

The most notable extensions and improvements to WinProp are listed by component.

ProMan

Features

- The currently displayed 3D view in ProMan can now be saved to a bitmap.
- The prediction area is now automatically adjusted to be equal to the smallest rectangle that includes transmitters and defined trajectories in case the dominant path model is used for prediction in indoor, urban or rural scenarios. Previously, this rectangle only covered the defined trajectory and results were not computed in case the transmitter was located outside the rectangle.
- Results along trajectories are now exported to an ASCII file in a tab separated format for each computed quantity during propagation modelling, mobile station post-processing or network planning. A unique trajectory identifier associates computed results to each trajectory defined in the project.

Resolved Issues

- The ProMan GUI now has added support for checks on the range of acceptable values that can be entered for path loss exponents of the dominant path model.
- Fixed a bug when computing the stream power results at a mobile station with more than one receiver. The best value from sub-channels associated with each receiving antenna is now correctly considered in the aggregated stream power results of the mobile station.
- An explicit error message is now issued for results in point mode with multiple prediction heights in a time-variant database.
- The specific transmit antenna used and its orientation (azimuth, tilt) are now written out in the result file, with channel matrices per point, that is obtained after post-processing with RunMS.
- Fixed a bug when computing propagation results of a rural project that uses a satellite transmitter in a database defined in geodetic coordinates.
- Changed the default angular orientation of the imported RCS data from **North (0) to East (90)** to **East (0) to North (90)**. The new orientation is in line with the conventional spherical coordinate system used in Feko.
- Fixed a bug that resulted in trajectory or point mode predictions not being automatically disabled when the area of planning is set to "Individual for each transmitter". For this setting, area wide mode is now automatically activated.
- Fixed a bug that resulted in propagation results associated with a carrier being displayed even after invalidating a computation by changing prediction parameters.
- Fixed a bug that resulted in an extra line, with the input coordinates, being written to the output file when converting from the longitude-latitude system to the UTM coordinate system.
- Fixed a bug that resulted in a failure to open the user guide from within WinProp applications in a server installation.

- Fixed a bug when defining the prediction area around cells. The default prediction area is now automatically selected when the simulation area is set to **Individual for each transmitter**. This allows for the definition of a single prediction area that applies to all cells.

Application Programming Interface

Resolved Issue

- Databases saved using AutoCAD file formats (.dxf and .dwg files) can now be converted into WinProp's database formats through the WinProp API on Linux.

Altair Feko 2019 is available with a long list of new features, corrections and improvements. Altair Feko 2019 is a major release. It can be installed alongside other instances of Altair Feko.

This chapter covers the following:

- [Highlights of the 2019 Release](#) (p. 362)
- [Feko 2019 Release Notes](#) (p. 364)
- [WinProp 2019 Release Notes](#) (p. 369)

Feko is a powerful and comprehensive 3D simulation package intended for the analysis of a wide range of electromagnetic radiation and scattering problems. Applications include antenna design, antenna placement, microstrip antennas and circuits, dielectric media, scattering analysis, electromagnetic compatibility studies including cable harness modelling and many more.

WinProp is the most complete suite of tools in the domain of wireless propagation and radio network planning. With applications ranging from satellite to terrestrial, from rural via urban to indoor radio links, WinProp's innovative wave propagation models combine accuracy with short computation times.

Highlights of the 2019 Release

The most notable extensions to Feko and WinProp in the 2019 release.

 **Note:** Legacy licensing support ends with the release of Feko and WinProp 2019. Contact Support for queries regarding the HyperWorks Units (HWU) licensing system.

Salient Features

- Support for diffraction effects from PEC edges or wedges in an RL-GO simulation.
- Extended GPU support for RL-GO including computations with dielectric materials, including dielectric sheets and coatings.

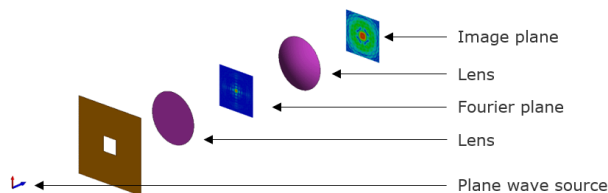

Figure 70: The optical 4F correlator (dielectric lenses) in the image simulates 16 times faster in Feko 2019 than in Feko 2018.2.1 on a laptop with Nvidia Quadro M1000M GPU.

- Significant reduction in run-time for power calculations for models involving many impressed near field sources.

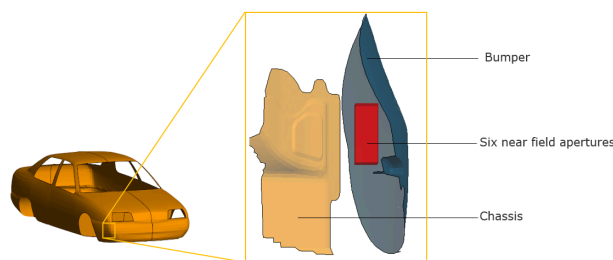

Figure 71: Side view of a radar antenna placement using 6 near field apertures, located in between the bumper and chassis.

- Memory estimation without performing the solution for models solved with PO, MoM and MLFMM with the command line option `--estimate-resource-requirements-only`.
- Improvement to loads with support for SPICE circuit loads and Touchstone (.s1p) loads. FEM line ports are extended to allow connections to non-radiating networks (that may be connected to sources or loads, but not to other geometry or mesh ports) via the schematic view.
- Improved display of GUI components on high resolution (4K) monitors. The applications get scaled with the operating system DPI setting for changing the size of items.

- Improved interaction between HyperMesh and Feko. A new Feko user profile in HyperMesh 2019 supports efficient mesh generation and material assignments for Feko in HyperMesh. Full bidirectional transfer of mesh and material data between Feko and HyperMesh is supported.

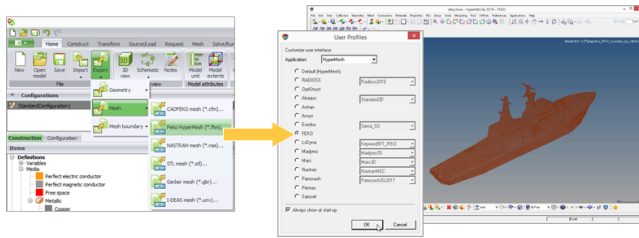

Figure 72: The Feko User Profile in HyperMesh ensures the generation of a valid mesh for Feko.

- WinProp extensions include:
 - Support for the use of radar cross section (RCS) information from Feko to represent objects in a database.

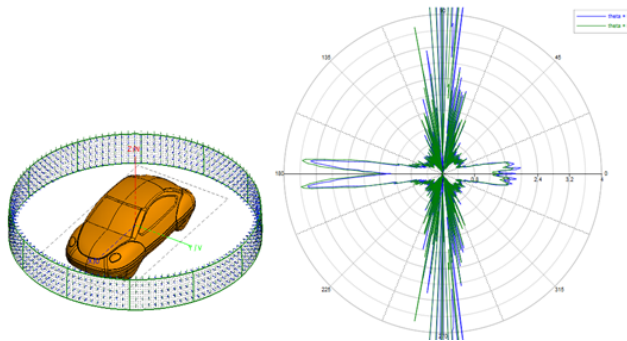

Figure 73: Feko-calculated RCS information can be included in a WinProp simulation through `.ffe` file import.

- Improved signal level plans with more complete display of component information and power levels.
- Various performance improvements in computations using the dominant path model.
- Support for Monte Carlo simulations and associated network planning to the WinProp API.
- Integration of the WinProp documentation into the HyperWorks documentation.

Feko 2019 Release Notes

The most notable extensions and improvements to Feko are listed by component.

CADFEKO

Features

- Added support to import and export Feko HyperMesh (.fhm) files.
- Extended FEM line ports to allow connections to SPICE or Touchstone networks via the schematic view.
- Added the ability to use 1-port SPICE circuit files as a load definition.
- Added the ability to use a 1-port Touchstone file as a load definition.
- Added a default interpolation method to the **Cable shield** dialog for the transfer impedance, surface impedance and transfer admittance definitions for a frequency dependent shield.
- Added validation for cable shield stretching ranges during CEM validate.
- Added support to specify the combined field integral equation (CFIE) factor on the **Solver settings** dialog. The magnetic field integral equation (MFIE) can now also be specified on the **Face properties** dialog.
- Added the option to the **High frequency** tab on the **Solver settings** dialog to enable or disable edge and wedge diffraction contribution for RL-GO.
- Modified the parameter sweep plugin to generate models in non-interactive mode.

Resolved Issues

- Improved the cleanup algorithm that removes activity logs. The presence of many log files resulted in slow application start time.
- Resolved an assertion failure with message ending in `m_portAnnotationMap.contains(pPortGroup)`. This assertion could be encountered when deleting a union which contains two or more wire ports, or undoing the deletion of geometry with multiple ports.
- Resolved an issue for imported meshes where the PEC setting was not correctly applied to faces associated with a FEM PEC region. This problem caused the solver to terminate with `Error 4564: Wrong specification of the medium for a metallic triangle.`
- Resolved a problem on the **Import mesh** dialog where the **Scale factor to metres** field was not applied when importing meshes in STL file format.
- Resolved a problem with the mesh export dialog introduced in CADFEKO 2018.2 for CADFEKO mesh (.cfm) format. The selection did not apply to the mesh exported to file.
- Corrected the .pre writing of the CR card for models containing a custom anisotropic reference workplane. This regression was present in CADFEKO 2017 (when using the optional mesh engine introduced in that version) and in CADFEKO 2018.
- Resolved an issue that prevented printing the notes view.

- Improved the **Create load** dialog. Images are displayed for all load types and the order of the editboxes (for the series and parallel circuit options) match the order of the checkboxes: Resistor, Inductor, Capacitor.
- Resolved the display issue on Windows 8 and 10 where disabled editboxes would turn white on mouse-over before returning to grey. This happened when the Windows appearance and performance setting "Animate controls and elements inside windows" was active.

EDITFEKO

Features

- Added support for Feko HyperMesh files (.fhm) files to the IN card.
- Added the ability to use a 1-port Touchstone file as a load definition to the L2, LC, LE, LF, LN and LZ cards.
- Extended FEM line ports to allow connections to SPICE or Touchstone networks via the NW and TL cards.
- Added a default interpolation method to the SD card for the transfer impedance, surface impedance and transfer admittance definitions for a frequency dependent shield.
- Added the option to enable or disable edge and wedge diffraction contribution for RL-GO on the UT card.

Resolved Issues

- Resolved a problem with the IN card where the **Scale factor** field was not applied when importing meshes in STL file format.
- Resolved an issue on the RA (receiving antenna) card where the "Use data block number" field appeared twice.
- Improved the responsiveness of the AR and RA cards. The opening and editing of these card panels slowed down with an increase in the number of theta and phi points, up to the point where the application seemed to hang.

POSTFEKO

Features

- Added support for font sizes larger than 20 and smaller than 6 points.
- Improved the handling of infinite values in continuous frequency results. Cartesian graphs no longer go blank if trace results contain infinite values. The infinite values are considered invalid and are not included on the graph.
- Updated the quick report templates with the latest Altair branding.

Resolved Issues

- Resolved an assertion failure that triggered when pressing Ctrl+A while an annotation was selected on a Cartesian graph. "Select all" functionality is not supported for annotations.

- Prevent the application from crashing when using the API to construct a matrix with a negative number of rows.
- The file browser filter, when exporting Touchstone data, is refined to use the specific file extension (corresponding to the number of ports being exported) instead of listing all Touchstone files.
- Resolved an issue where Lua script dialogs lost focus behind the POSTFEKO application when focus was placed on a graph or 3D view.
- Updated the parameter sweep plugin to store characteristic mode data as characteristic mode results instead of as custom results.
- Fixed the parameter sweep plugin to store receiving antenna data as custom results. These results were incorrectly stored as power results.

Solver

Features

- Added support to load a FEM line port with a non-radiating network. S-matrix, Z-matrix, Y-matrix and SPICE circuits are supported. FEM line ports cannot currently be connected via a non-radiating network combination.
- Added support for RL-GO simulations of dielectric models on the GPU.
- The IDs of the triangles, polygons or cylinder hit by a ray are now exported to the `.ray` file for geometries solved with RL-GO or UTD.
- Added support for diffraction effects from PEC edges or wedges in an RL-GO simulation.
- Added support for continuous far field request for models solved with RL-GO only, as well as those involving a hybrid MoM and RL-GO solution. For the latter case, continuous far field requests are only possible if there is a pre-existing `.str` file.
- Significantly reduced the run-time of power calculations for models involving many impressed near field sources.
- Introduced a mechanism to estimate memory requirements, for models solved with PO, MoM and MLFMM, without ever performing the solution. An estimate of the memory requirements is available in `--estimate-resource-requirements-only` mode.
- Added support for the description of frequency domain loads (segment - LZ, vertex - L2, edge - LE, cables - LC, networks - LN, FEM line port - LF) using a 1-port Touchstone file.
- Disabled parallel simulations through OpenMP threading. MPI parallelisation is used instead and is supported for more phases and solution methods. In some cases MPI performs better than OpenMP, even on shared memory systems.
- Updated Intel MPI to version 2018.0.4.
- Updated Intel MKL to version 2018.0.4.
- Feko's cluster computing based on MPI now also supports HPE-HMPT. Note that this is not shipped with Feko and must be installed separately.

Resolved Issues

- When using periodic boundary conditions in connection with incident plane waves, inaccuracies in the solution can occur when the incident angle of the plane wave coincide with the PBC direction of

periodicity. Such cases are now detected inside the Feko solver and warnings or errors are issued to alert the user.

- Adjusted the internal threshold for RL-GO when far field calculations switch to a faster but more memory demanding algorithm. This results in improvements in solution time for large models, at the expense of increased memory usage.
- Improved the mechanism behind exporting rays to the `.ray` file by not repeating identical ray path sections, leading to a significant reduction in the size of the exported file. Moreover, a decrease in the memory requirements of an RL-GO solution is achieved when the option to export rays is selected.
- Fixed a bug that led to an internal error state when running Feko in `--mtl-circuit-export` mode for shielded cables.
- Fixed a bug that resulted in a floating point exception when solving models with periodic boundary conditions.
- Fixed a bug when computing the contribution of multiple non-radiating network ports connected to a common segment.
- Fixed a bug that led to an error state when the Domain Green's function is applied to a finite array model containing dielectrics solved with the surface equivalent principle (SEP).
- In some cases, the Feko solver allocated a large amount of memory during the geometry setup and checking phases when modelling dielectric bodies with SEP. This could happen when dielectric bodies with many mesh elements were spread over a large geometrical extent, for example, for multiple widely-separated bodies. A new refined algorithm reduces this memory requirement significantly.
- Fixed a floating point exception that occurs on specific Windows and CPU systems during the ACA matrix compression phase.
- Fixed a bug when determining convergence of an FDTD solution based on a user-defined convergence threshold. The time-domain solution now stops after ensuring convergence based on the user-defined threshold.
- Fixed a bug that led to the inner residuum, rather than the outer residuum being written out to the `.cgm` file of a stabilised MLFMM solution.

Shared Interface Changes

Features

- Added support for the bidirectional transfer of mesh and material data between Feko and HyperMesh through the new Feko HyperMesh file (`.fhm`) format. Through the new Feko user profile in HyperMesh, these files can be imported and exported by HyperMesh while Feko is able to import and export these files using the standard mesh import and export options.
- Upgraded the graphical user interface to use Qt 5.9.6.
- Upgraded OpenSSL to version 1.0.2p.
- Removed the option to **Use shared memory / OpenMP threading for multiple CPU nodes / multicore CPUs** from the **Component launch options** dialog due to this option being deprecated.

- Removed the PREFEKO "Debug options" group from the **Component launch options** dialog.

Resolved Issues

- Fixed a bug that resulted in the incorrect version of the Windows operating system being written to the `.out` file. This affected computers running a version of Windows newer than Windows 8.1.
- Single quotes are no longer stripped from command line arguments on Windows platforms. A string should be surrounded by double quotation to be interpreted as a single argument.
- Resolved a display issue that caused tiny icons and fonts on high DPI monitors.
- Renamed the parameter sweep script in the application macro library. The CADFEKO script is called "Parameter sweep: Create models" and the POSTFEKO script "Parameter sweep: Combine results".
- Fixed a bug when determining the external input files required for a Feko solution. Optional files, such as `.str` files, are now only listed if they exist.

Support Components

Features

- Ended support for legacy licensing. Feko and WinProp make use of the HyperWorks Units licensing system and the Altair License Utility for licence management. The SECFEKO Legacy Licence Manager utility is discontinued.
- Dropped support for encryption in QUEUEFEKO.
- Included modal information from FEM modal ports in a solution with a continuous interpolated frequency range (ADAPTFEKO).
- Added support for Feko HyperMesh files (`.fhm`) files in PREFEKO.
- Validation is performed when updating from local directories. The updater will issue an error if subdirectories are selected and, if possible, suggest the correct path.
- Added a WinProp section to the **Documentation** tab of the Launcher utility. This section provides quick access to the WinProp HTML help and User Guide.
- Added a new "Scripting and API Reference Guide" PDF document with information on the CADFEKO and POSTFEKO Application Programming Interface (API). This content is split off from the Altair Feko User Guide (PDF). The information can be found in the HTML help in the same location as before.

Resolved Issues

- Improved application positioning behaviour when moving between different monitor combinations. All applications, including the Launcher, should now be displayed on the active screen when a monitor that was previously used to display the applications are unavailable.
- Fixed a bug in PREFEKO that resulted in the error `Data block map could not be determined for file - ABORTING FILE OPERATION` when importing a near field in the Cartesian boundary coordinate system format as near field source.

WinProp 2019 Release Notes

The most notable extensions and improvements to WinProp are listed by component.

General

Features

- Ended support for legacy licensing. Feko and WinProp make use of the HyperWorks Units licensing system and the Altair License Utility for licence management.
- Added links to launch the HTML documentation from within the various WinProp applications. The links can be accessed from the help (?) menu.
- An updated and unified user manual is now accessible from the help menu of all WinProp applications.
- All the WinProp examples have been reviewed and improved. Each example also has an accompanying document describing the example.
- Added information to the installation guide regarding the limitations imposed by the student editions of Feko and WinProp.
- Updated the documentation to reflect the implications of using adaptive resolution management with the urban dominant path model.

Resolved Issues

- Significantly improved simulation times of predictions done with the dominant path model. Improvements by an order of magnitude can be achieved for models with a fine resolution.
- Improved the performance of indoor scenario simulations when there is no furniture in a preprocessed database.
- Updated documentation to reflect the supported command line directive for filtering computed results.

ProMan

Features

- Default values for the dominant path propagation model are now identical between the WinProp GUI and API.
- Clutter losses are now supported in urban scenario simulations with the dominant path model.
- Updated the default values of the path loss exponents used in the dominant path model for rural scenarios to improve prediction accuracy.
- Added support for exporting the signal level plan, with the associated power budget information, to a `.dxf` file when components are used.

- Significantly improved the performance of radar simulations with ray-tracing models by adding support for the use of radar cross section (RCS) information, obtained from Feko, to represent objects in a database.
- Improved the accuracy of scattering loss computations for ray-tracing-based propagation models.
- The option to cancel the determination of further rays if free space loss is reached, is no longer activated by default for newly created urban IRT projects.
- The version number of WinProp is now printed in the header of ASCII result files.
- Added support for clutter databases in the project export tool in ProMan.

Resolved Issues

- Significantly improved simulation times of predictions done with the dominant path model. Improvements by an order of magnitude can be achieved for models with a fine resolution.
- Fixed a bug that led to instabilities in the user interface when setting parameters for a Monte Carlo network planning simulation.
- Fixed a bug that led to the association of computed results with the wrong time steps in a project with mixed static and time-varying receiver points.
- Fixed a bug that prevented the modification or editing of components defined on different floors in a multi-floor building.
- Fixed a bug that resulted in an infinite loop while generating Keysight PROPSIM output files.
- Improved the efficiency of simulations with the rural dominant path model in a project that does not consider building pixel databases.
- Fixed a bug that resulted in wrong delay data being written to the `.str` file for all time steps, except the first, during mobile station post-processing of a time-variant database.
- Fixed a bug that led to the antenna pattern at the base station not being considered during the computation of channel capacity.
- Fixed a bug which resulted in diffractions at a prediction plane erroneously being taken into account for the particular case where a prediction plane is aligned with other walls in a database.
- Fixed a bug that led to arbitrary values, for electrical properties (dielectricity and conductivity) of the ground, not being considered in the ITM propagation model. The definition of such values is now correctly handled.
- Fixed a bug that led to received power not being computed, during post-processing with RunMS, when the receive antenna is titled at 90 degrees.
- Fixed a bug that resulted in failures when reading patterns of antennas loaded from the components database.
- Fixed a bug that caused a crash when exporting the coverage report for a project containing components.
- Opening a WinProp project from the command line without passing any additional directives no longer launches a propagation simulation. Explicitly define the appropriate command line directive to launch a simulation.
- Fixed a bug that led to results not being computed in the special case where the transmitter is located at the centre of a pixel in the prediction grid.
- Fixed a bug that led to a crash in the ProMan GUI when moving a component (antenna, amplifier and so forth) to a different location in a building.

- Fixed a bug that led to an error when creating a new topographical database.
- Fixed a bug causing incorrect results when using the rural dominant path model in a database where the effects of the curvature of the earth are considered.

Application Programming Interface

Features

- Default values for the dominant path propagation model are now identical between the WinProp GUI and API.
- Added support for Monte Carlo simulations and associated network planning in the WinProp API.
- Added support for multi-threading during network planning via the WinProp API on Linux.
- Resolved differences observed in results when some projects are computed using the WinProp API and the ProMan GUI. The API now correctly uses the option "Fresnel coefficients for transmission/reflection and GTD/UTD for diffraction" when required. The API parameter **InteractionModel** moved from the **Model_RAYTRACING** struct to the **WinProp_Additional** struct.

Resolved Issues

- Significantly improved simulation times of predictions done with the dominant path model. Improvements by an order of magnitude can be achieved for models with a fine resolution.
- Fixed a bug that led to courtyards not being properly accounted for when computing propagation results using the WinProp API with the urban database defined in memory (not as a .odb file).

Release Notes: Altair Feko 2018.2.1

Altair Feko 2018.2.1 is available with new features, corrections and improvements. This version (2018.2.1) is a patch release and it should be applied to an existing 2018 installation.

This chapter covers the following:

- [Feko 2018.2.1 Release Notes](#) (p. 373)
- [WinProp 2018.2.1 Release Notes](#) (p. 375)

Feko 2018.2.1 Release Notes

The most notable extensions and improvements to Feko are listed by component.

POSTFEKO

Resolved Issues

- Resolved a performance issue when exporting or importing Y or Z parameters. The performance degraded with an increase in the number of ports, up to the point where the application appeared to hang.
- Fixed an assertion failure with the critical error message `Assertion failed: getAxisSet().isSubset(markedAxisSet.extractMarkedAxisSet())`. Following the POSTFEKO API name change of the "Arbitrary" axis to "S-parameter" in Feko 2018.2, this assertion would fail when plotting stored S-parameter data obtained from an S-parameter dataset using "Arbitrary" as axis name.
- Improved the performance of importing ASCII custom data files.

Solver

Features

- Improved matrix fill time of models with periodic boundary conditions.
- Updated NOTE 35127, which is printed for sequential simulations, to better reflect the general parallel simulation possibilities afforded by the HWU licensing scheme.

Resolved Issues

- Added error checking mechanisms related to the treatment of FEM models that touch the boundary of a periodic unit cell. FEM regions are required to touch both sides of a PBC unit cell, and material indices appearing on one side of a unit cell should match those on the opposite side.
- Resolved a bug that led to an error state during the ray-launching phase of an RL-GO solution.
- Fixed a bug that caused parallel cable examples to hang where multiple configurations with a load utilising the SPICE circuit definition is defined as a global (over all configurations) option.
- Fixed a bug affecting MoM/RL-GO problems where the results of the second configuration were incorrect when solving two identical configurations consecutively.
- Fixed a bug that resulted in inconsistent configuration specific port information between processes in a parallel simulation.
- Fixed a bug in the evaluation of high order basis function models with periodic boundary conditions.
- Fixed a bug in the error checking phase of the solution of a model with periodic boundary conditions.
- Improved the consistency of mesh representations in the solver when a model is meshed with planar as well as curvilinear triangles.

- Fixed a bug related to memory access on a GPU during the computation of far fields with the FDTD method for a large number of frequency points.
- An explicit error message is now issued when out-of-core files are deleted during an MLFMM iterative solution with sparse LU preconditioning.
- The used CFIE factor, as specified on the CF card, is now written to the `.out` file.
- Resolved an error state caused by numerical tolerances in models solved with the multi-layer Green's function.

WinProp 2018.2.1 Release Notes

The most notable extensions and improvements to WinProp are listed by component.

ProMan

Features

- Added knife edge diffraction to the deterministic two-ray propagation model.
- Added support for the deterministic two-ray propagation model for rural scenarios in the ProMan GUI as well as the WinProp API.
- Post-processing of propagation results in point mode, with RunMS, is now possible for indoor and rural scenarios.

Resolved Issues

- Improved the performance of urban propagation simulations with the dominant path model involving topographical details.
- For a receiver with multiple antenna elements, per-stream results are now available for viewing in the results tree browser.
- Fixed a bug that led to an error message being displayed when connecting components with a cable.
- Fixed a problem with Legacy Licensing (non-HyperWorks Units licensing) involving a dongle, where a valid license ID was not recognized.
- Fixed a bug that led to the offset location of individual receiver antenna elements being reset in the ProMan GUI.
- Fixed a crash that could occur during the import of transmitters from a `.CSV` file when there was a mismatch between the delimiters specified on the import dialog and those in the file.
- Fixed a bug in Line-of-Sight results that could occur in an urban scenario with topography.
- In version 2018.2, the path delay after RunMS could be different from that of RunPro. This incorrect behaviour is fixed.
- The project export functionality now maintains the folder structure of the results.
- Fixed a bug when displaying network planning results for receiving points defined at different heights.
- Corrected the logic during the selection of vector databases when creating a project, to prevent an inappropriate selection that resulted in a crash.
- Updated the user interface, when specifying the receiver antenna, to only show the relevant settings for each type of receiver antenna.

WallMan

Features

- The definition of the UTM zone is now allowed during conversion of UTM data.

Resolved Issues

- Fixed a bug that led to an error state in the graphics component of WallMan.
- Fixed a bug during UTM zone determination when converting an urban database.
- Fixed a bug that resulted in an offset in building heights, relative to ground, during conversion of an Open Street Map database.
- Fixed a bug that could cause a crash during pre-processing of a CNP database for intelligent ray tracing.
- Information about removed walls is now printed to the progress window when converting a `.dxf` file with non-planar structures.

AMan

Resolved Issues

- Fixed a bug in the generation of `.ffe` (far field) files by AMan. In some cases the `.ffe` file could not be imported by Feko.

Application Programming Interface

Features

- Updated the licensing mechanism to consider parallel computations in the API. The license draw is now consistent with that of the ProMan GUI in its dependence on the number of parallel threads.

Resolved Issues

- Added support for building and material type definitions in the urban API.

Release Notes: Altair Feko 2018.2

48

Altair Feko 2018.2 is available with new features, corrections and improvements. It can be applied as an upgrade to an existing 2018 installation, or it can be installed without first installing Altair Feko 2018.

This chapter covers the following:

- [Highlights of the 2018.2 Release](#) (p. 378)
- [Feko 2018.2 Release Notes](#) (p. 380)
- [WinProp 2018.2 Release Notes](#) (p. 386)

Highlights of the 2018.2 Release

The most notable extensions and improvements to Feko and WinProp in the 2018.2 release.

Salient Features

- Periodic boundary conditions (PBC) supported with FEM and significant performance improvements to PBC simulations.

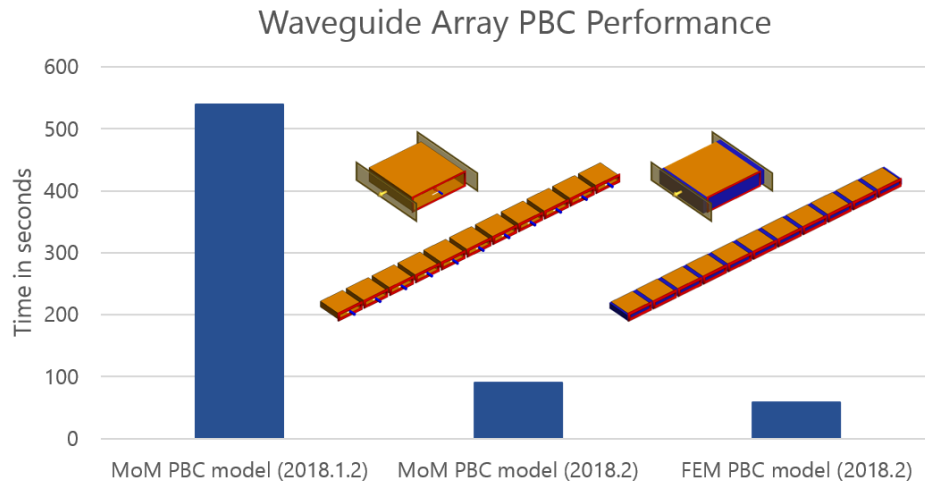

Figure 74: An 11x11 waveguide array solved at 1.645 GHz. The image shows the performance of the MoM PBC array solved with Altair Feko 2018.1.2 compared to the MoM PBC array solved with Altair Feko 2018.2 and the FEM PBC array solved with Altair Feko 2018.2. The PBC unit cells for the MoM and FEM models are shown as inserts with the 3D views of the models. The simulations were completed on a standard desktop computer (Intel® Core™ i5-4690 CPU @ 3.50GHz).

- Improved RL-GO curvilinear ray tracing speed.
- Improved POSTFEKO performance with faster loading times for large result and session files and faster time analysis of continuous frequency results.
- Support for double cable shields and braid formulations in CADFEKO.

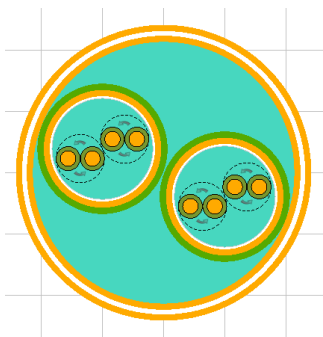

Figure 75: CADFEKO cross-sectional view of a cable bundle with double shields.

- Improved loading options to be more consistent for various solution methods.

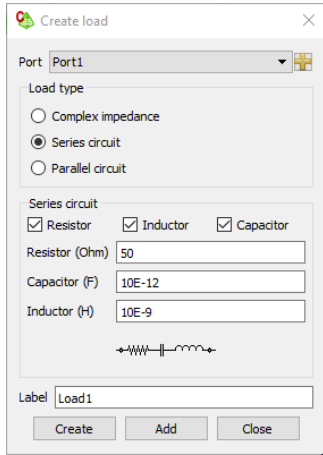

Figure 76: The **Create load** dialog now shows an image of the resulting circuit.

- Option to use new or keep existing ports and sources when unlinking a mesh.

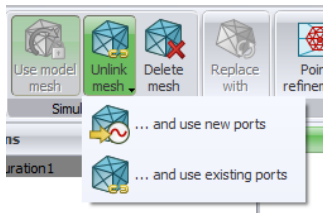

Figure 77: New unlink mesh options.

- Ability to simulate automotive radar in WinProp.

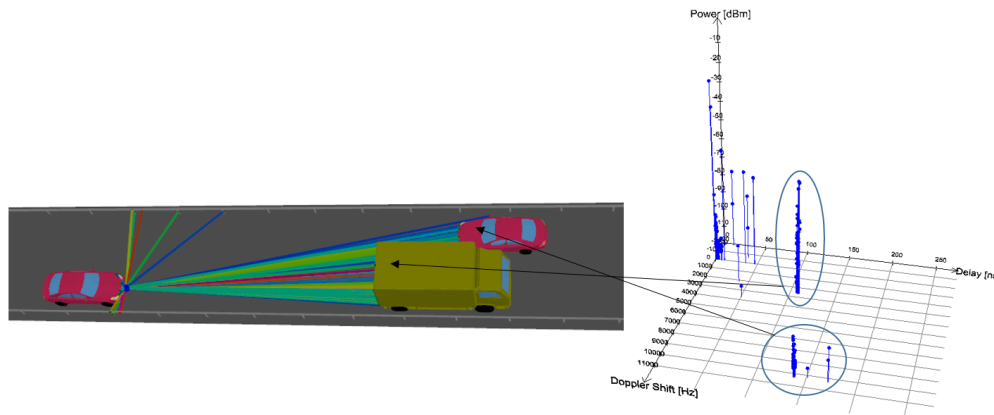

Figure 78: An automotive radar simulation in Altair WinProp.

- WinProp application programming interface (API) under Linux.

Feko 2018.2 Release Notes

The most notable extensions and improvements to Feko are listed by component.

CADFEKO

Features

- The shield insulation coating is moved to the coaxial cable and bundle dialogs. Validation for the stretching range of a braided shield is added when applying a braided shield to a coaxial cable or bundle.
- It is now possible to specify the transfer capacitance to approximate the admittance part of a cable shield definition.
- Added support for the Tyni and Demoulin braid formulations in addition to the Kley and Vance methods for a braided shield. Furthermore, the optical coverage definition is added to specify the size of the apertures for a braided shield. The weave angle definition was extended to include a weave angle deviation to take into account possible variations in the weave angle when the shield is stretched. A maximise optical coverage optimisation method is added to maximise the shielding when applying the shield on a coaxial cable or cable bundle. The weave angle and shield radius can also be specified manually if the weave angle is different from the optimal value determined from the maximise optical coverage optimisation method.
- Added direct support on the cable shield dialog to define double-layered shields.
- Added support for the surface impedance definition for a frequency dependent shield to take on a low-frequency braid-approximation ($Z_s=Z_t$), manually specify the data or load the properties from a file. Interpolation methods (Constant, Linear, Cubic spline and Rational) are added to the transfer impedance, surface impedance and transfer admittance definitions for a frequency dependent shield.
- Improved the unlinking of meshes by introducing an option to transfer sources, loads and other solution entities to the ports on the unlinked mesh. The old behaviour to keep using existing ports is retained as an alternative option.
- Improved the **Create load** dialog to clarify that the impedance calculation does not include zero-value elements. A resistor, capacitor and inductor can now be added or removed from the load circuit by toggling checkboxes on the dialog. A newly introduced image on the dialog updates to show the resulting schematic circuit.
- Extended far field requests to support the Cartesian coordinate system to define points on a regular Cartesian grid. This is in contrast to the default regular theta/phi grid requested when using spherical coordinates.
- Added an option to choose whether the port reference is absolute or relative when defining a non-radiating general network with a SPICE circuit.
- Series and parallel circuits are supported for loads on vertex, microstrip and network ports (in addition to complex impedances).

Resolved Issues

- Corrected CEM validation to allow current sources with the incident power scaling (transmission line model) power scaling option.
- Improved periodic boundary condition tests for finding matching faces on corresponding boundaries by increasing the tolerance.
- Fixed a regression introduced in FEKO 2018. Curved UTD faces are once more discretised into triangles when symmetry is applied.
- The cable path identical distance is reduced from $1e-4$ to $1e-6$. This allows cable end points to be located 100 times closer to each other than in previous versions.
- Resolved an issue with configuring Braided (Kley) cable shield method when setting different inside and outside dielectric braid-fixing material.
- Corrected a CEM validation check that failed with the warning `No sources have been defined in the model` when the voltage source magnitude was set to a value smaller than 0.5 V.
- Corrected the CEM validate check to allow free space MoM regions with VEP dielectric regions.
- Corrected an issue with CADFEKO model import. After importing a `.cfx` file, automatic meshing was unable to complete until a change was made to the model frequency.
- Resolved a meshing issue where a non-uniform surface mesh was generated close to a symmetric wire with ports located normal to the plane of symmetry.
- Excluded windscreen reference triangles from mesh intersection checks. These elements only define a reference position and do not form part of the solution. It does not result in a simulation error when these elements intersect with other elements.
- Prevented warnings from being issued when saving a model containing valid finite conductivity faces defined on a FEM PEC region.

EDITFEKO

Features

- Extended the FF card to allow using the Cartesian coordinate system when requesting far fields.
- The SPICE Circuit (SC) card is added to EDITFEKO. This card defines a 1-port SPICE circuit for subsequent use in load cards (L2, LC, LE, LF, LN and LZ).
- Additional load options (specifying a SPICE, series or parallel circuit) are available on the L2 and LN cards.

Resolved Issues

- The "Include tetrahedral elements" flag is now on by default when adding an IN card in EDITFEKO.

POSTFEKO

Features

- Extended POSTFEKO to support far fields specified in Cartesian coordinates.

- Added support for loads specified using 1-port SPICE circuits (SC card).
- Improved the handling of HTML styling applied to graph captions and text via the API.
- Added support for characteristic modes requests with looped plane wave sources.

Resolved Issues

- Improved the time analysis calculation speed for continuous frequency results. Some examples show speed improvements of up to 20 times.
- Resolved a performance issue when loading large POSTFEKO session files. The loading times of large `.pfs` files are significantly reduced.
- Windscreen layers and wire coatings are now displayed correctly in POSTFEKO regardless of the model unit.
- Corrected FEM load handling to consider two loads with different orientations to be the same load instead of two different loads. The second load would replace the definition of the first load.
- Resolved a crash when attempting to export S-parameters or arbitrary near field points to a `.mat` file.
- Resolved an assertion that failed with `index < pBlock->nports` when attempting to view the data for the second port of a non-radiating network.
- Added additional error checks to the `.ini` file reading process to give an error and reset the `.ini` file instead of failing to start the application.
- Fixed axis support is added for the transmission/reflection coefficient collection in the API.
- The axis for S-parameter DataSets can now be referenced as `s-parameter` in the API. Similarly, the alias `MediumNames` is added on the metadata of Near Field DataSets and `PortNumber` for the axis listing the port number on a Network DataSet. These axes were previously accessed as "Arbitrary" axes. Backwards compatibility is maintained, allowing the use of either `Arbitrary` or the new names when accessing the data.
- The `ModalExcitationCoefficientIsCalculated` flag is moved to the metadata of characteristic mode datasets in the API. The `ModalExcitationCoefficient` quantity is now only added to the dataset when it is requested. In the past, the value of $0 + i0$ was added to the `ModalExcitationCoefficient` quantity when it was not requested in the simulation.

Solver

Features

- Updated the minimum number of unknowns for which a model can be solved efficiently with ACA to 10000.
- Support periodic boundary conditions for dielectric bodies with FEM.
- The quality of the MLFMM load balancing between the different processes in a parallel run is now written to the `.out` file. This feature can be used with the `--check-only` option (thus not solving the model).
- Significantly improved the performance of all simulations involving periodic boundary conditions (PBC). The performance is improved by one to two orders of magnitude while maintaining accuracy.

- Improved intersection checks between rays and geometry meshed with curvilinear triangles, leading to a significant speed-up of the ray launching/tracing phase of RL-GO. Further improved robustness of tracing rays close to grazing incidence.
- Improved the accuracy of RL-GO with adaptive ray launching settings.
- Improvement of the accuracy for the asymptotic RL-GO solver when impressed sources (including aperture sources) or MoM regions are very close to RL-GO region, as well as run-time reduction for the MoM / RL-GO hybrid method. As a result of this improvement, ray amplitudes exported to the `.bof` and `.ray` files now reflect the magnetic field strength along the ray path, no longer the electric field strength.
- Added support for the calculation of modal excitation coefficients for all angles of a plane wave with multiple angles of incidence during characteristic mode analysis.
- Improved the efficiency of computations involving loads defined on an edge, a vertex or a FEM load, defined in multiple configurations. Data calculated from a previous configuration get re-used if the loads do not change.
- Support far field computations in a Cartesian UV grid.
- Support the use of a general non-radiating one-port SPICE circuit as a complex load applied to a port (segment, vertex, edge, cable, network or FEM line port) in frequency domain solvers.
- Support SPICE circuits with pairwise relative port references connected to a non-radiating general network.
- Support series and parallel RLC loads applied to a wire port that is defined on a vertex.
- Support series and parallel RLC circuit loads applied to a non-radiating network port.
- Parallel processing of geometry intersection checks is supported and the progress output is updated during this phase.
- Memory usage is now consistently reported at the same location in standard output and the `.out` file when iterative solvers, such as FEM or MLFMM, are used.

Resolved Issues

- Fixed a bug that led to an error state during a solution with adaptive cross-approximation.
- Single or double precision data storage information is now written to the `.out` file for ACA.
- Corrected the logic when configuring solution settings involving general network ports.
- Improved the performance of the interpolation phase of a PBC solution by two orders of magnitude on average.
- An error message is now issued for a PBC model containing curvilinear segments.
- Removed a note that was issued if all triangles in the mesh of an RL-GO model are found to be planar despite curvilinear meshing being enabled.
- Added geometry intersection tests between cable paths and a PEC ground plane.
- Added a check for the consistent definition of microstrip edge ports with associated load or excitation across all configurations.
- Resolved a bug that led to an internal error state when computing SAR by improving tolerances used in identifying the medium of an observation point.
- Fixed a bug that led to a parallel deadlock during the geometry checking phase of the solution of a closed surface modelled with CFIE.

- Resolved a circular dependency in the memory initialisation of RL-GO
- Restricted the check for a metallic surface in a mixed FEM/MoM model with connected FEM and MoM regions to the FEM/MoM boundary.
- Refined the grazing angle threshold to improve the accuracy of RL-GO with adaptive ray-launching settings for models with spherical mode sources near RL-GO surfaces.
- Do not print a warning when there is a CUDA driver mismatch if GPU usage is not requested.
- Fixed a bug that led to a memory error state on Windows for a cable model with capacitor connections to ground.
- Fixed a bug in the calculation of modal input power during a characteristic mode analysis solution.
- Fixed a bug in the calculation of network losses in models with more than one configuration.
- Fixed a bug that led to an error state when parallel computations are executed on Windows on some CPUs.
- Fixed a bug that led to an error state when estimating the condition number in parallel in Windows.
- Fixed inconsistencies in recovering a corrupt or incomplete `.str` file between processes, in a parallel simulation. Current file recovery is now exclusively handled by the main process.
- Improved the handling of non-radiating networks, through abstract representations, and increased the efficiency of the solution. As a by-product, a series load at a port, where a non-radiating network is also attached, is now allowed when S-parameters are requested.
- Improved the handling of Touchstone data embedded in a SPICE circuit that is included in a non-radiating general network, resulting in a significant reduction in simulation time.
- Corrected an error in the logic to use the fast far field method for RCS calculations with RL-GO.
- Corrected text related to the number of MoM basis functions reported in the `.out` file for an RL-GO only model.
- Improved MLFMM memory management and the accuracy of the reported memory usage of the near field matrix when the SPAI pre-conditioner is used.
- Changed the MoM treatment of an RLC circuit load with all three components equal to zero to evaluate to an open circuit. The usage of such loads in a model now results in an error.
- Improve message reported in the `.out` file when intersections are detected to indicate possible causes.
- Fixed a bug that resulted in an error state when updating the percentage progress output of a time domain solution.

Shared Interface Changes

Features

- Altair products are branded more consistently. FEKO is renamed to Altair Feko across the interface.

Resolved Issues

- Renamed "port impedance" for sources to "reference impedance" to avoid confusion. These reference impedances do not terminate the ports in actual impedances but serve as reference values for calculating the reflection coefficient.

- Resolved the slow response rate of the search bar. This regression introduced in FEKO 2018.0.2 could result in incorrect search bar input when characters were missed during typing.

Support Components

Resolved Issues

- Replaced the PREFEKO triangle-based meshing by a polygon-based meshing solution.
- Extended the User Guide and Installation Guide on where to download the feature updates/hotfixes and how to correctly set up a local repository to prevent receiving the error that the `manifest.xml.gz` file could not be found.
- A new section on “How-Tos” is added as an appendix to the Feko User Manual. In this section, steps are provided to address specific, often more advanced, problems.
- Added information on how to create a response file for silent mode installations. This information was missing in the 2018.1 Installation Guide.

WinProp 2018.2 Release Notes

The most notable extensions and improvements to WinProp are listed by component.

General

Resolved Issues

- Fixed a bug that prevented the automated use of OptMan.

ProMan

Features

- Support for pre-processing of databases for IRT has been extended to time-variant scenarios in WallMan. IRT simulations in ProMan now also support time-variant scenarios.
- Extended post-processing of mobile station propagation results to time-variant scenarios in area-wide and point modes.
- Significantly improved the workflow of MIMO network planning by having all results provided in one simulation.
- WinProp radio channel data can be exported to the ASCII format supported by Keysight PROPSIM.
- Doppler shift calculation is available for time-variant scenarios. The Doppler shift data is included in the `.str` file and can be displayed on 2D and 3D plots.
- Adaptive orientation of a transmit antenna (azimuth, down-tilt), attached to a moving part of a time-varying database according to the trajectory of the moving object, has been added.
- Added support for prediction points and prediction planes at multiple prediction heights during post-processing of mobile stations.
- Antenna pattern resolutions smaller than one degree are now supported.
- Support for radar channel results for multiple frequency bins is now added to the post-processing utility, RunMS. Multiple frequency results, at the receiver, are now obtained in one simulation run.
- Added support for post-processing results in horizontal planes at multiple prediction heights in indoor scenarios.
- Included effects of the gain of the mobile station antenna in the ray data written during mobile station post-processing.
- Improved accuracy and usability for mobile station post-processing by disabling adaptive resolution management, by default, for all scenarios.

Resolved Issues

- Corrected the behaviour of ProMan to issue an explicit error message in case a failure occurs when checking a license.
- Fixed a regression that led to incorrect coherently superposed power results when using the Standard Ray Tracing method.

- Fixed a bug that led to a crash when viewing the channel impulse response of a time-variant project.
- Fixed a bug that led to a crash when displaying channel impulse response over a topological vector database.
- Fixed a regression that led to a crash during network planning simulation with a rural database.
- An additional mean-value result was added, for which logarithmic results are first converted to linear before the mean is taken. The mean is then converted back to dB.
- Fixed a bug in the consideration of the azimuthal orientation of a single receiving antenna.
- Corrected a bug in the consideration of the gain of the antenna at the mobile station during received power calculations.
- Fixed a bug in which the angle of a linear array in RunMS could be considered twice and thus unintentionally doubled.
- Fixed a bug that caused the orientation of the antenna to be displayed with a 90 degree rotation for time-variant simulations.
- Fixed a bug during the computation of angles of departure for a transmitter attached to a time-variant part of a database. The computation now takes into account the position of the transmitter in time.
- Fixed a bug that led to ray interaction points to be displayed below the topography of the terrain, when the pixel data of the topography is converted to vector data with the option of dividing each pixel into two triangles.
- Fixed a bug that led to a crash if a prediction area, trajectory or point is not defined in the project. An explicit error message is now issued for this case.
- Fixed a bug that led to crash for an urban database simulated with an empirical knife-edge model.
- Fixed a bug when post-processing mobile station results for a specific combination of the defined polarisations at the transmitter and receiver.
- Angular mean, delay spread and angular spread calculations are now restricted only to ray-optical propagation models where it is possible to compute these metrics as more rays are available.
- Corrected the computation of angles of departure, for trajectories in the line of sight of a transmitter, during post-processing.

WallMan

Features

- Support for pre-processing of databases for IRT has been extended to time-variant scenarios in WallMan. IRT simulations in ProMan now also support time-variant scenarios.
- Support for pre-processing databases for IRT, with a pre-specified prediction point, has been added.

Resolved Issues

- Fixed a bug in the conversion of HGT (1arc) files to topo databases.

Application Programming Interface

Features

- The ray matrix is now accessible through the API for outdoor predictions.
- Fixed several bugs in the API, and added a few missing parameters in the API. As a consequence, discrepancies in results between projects in the API and the GUI have been eliminated.
- The WinProp API has been ported to Linux. A C++ example that can be used with the Linux API is located in `../feko/api/winprop/source/apismall.cpp/` and is described in `../feko/api/winprop/ReadMe.txt`.

Resolved Issues

- Resolved a bug in urban scenarios in the API that led to only path loss being computed regardless of the requested output.
- Corrected `.str` file handling through the API for urban projects.
- Reconciled the definition of the DPM prediction area in the API with that of the GUI to avoid the possibility of small discrepancies.

Release Notes: Altair Feko 2018.1.2

Altair Feko 2018.1.2 is available with new features, corrections and improvements. This version (2018.1.2) is a patch release and it should be applied to an existing 2018 installation.

This chapter covers the following:

- [Feko 2018.1.2 Release Notes](#) (p. 390)
- [WinProp 2018.1.2 Release Notes](#) (p. 391)

Feko 2018.1.2 Release Notes

The most notable extensions and improvements to Feko are listed by component.

Solver

Resolved Issues

- Fixed a bug that led to an internal error when extracting parts of the CMA matrix.
- Fixed a bug that caused the reflection and transmission coefficients to be larger than one for PBC models with a dielectric coating.
- For cable harness modelling, the solver will report all cable signal information when no installation (reference ground represented by triangles or a ground plane) is defined below the cable. Previous versions would not provide information of the return signal in POSTFEKO or in the `.out` file.
- Increased the size of the messaging buffer to prevent an error state during an MPI parallel solution.
- Fixed a bug that caused TR results to be written out incorrectly when multiple TR requests written to `.tr` files are present inside plane wave loops and results at multiple frequency points are requested.
- Fixed a bug that resulted in the wrong current being displayed for PBC models, solved using HOBf, that touch the unit cell walls.

Support Components

Resolved Issues

- Issue a warning instead of an error when importing a binary `.stl` file when the expected number of elements are not present.
- Improve error message when reporting XSD file creation during CST NFS import.

WinProp 2018.1.2 Release Notes

The most notable extensions and improvements to WinProp are listed by component.

ProMan

Resolved Issues

- RunMS (not RunPro) gave incorrect results for received power in versions 2018.1 and 2018.1.1 due to an incorrect internal conversion from power to field strength. This is fixed.
- Fixed a bug that resulted in incorrect angles of departure when the height of the transmitter is set relative to the ground's topology.
- For a MIMO antenna array at the mobile station, if receiving antennas were isotropic without an actual imported antenna pattern, the received power was incorrectly calculated as if there had been only a single isotropic receiving antenna. This has been fixed.
- Fixed a bug that resulted in the absolute height of a transmitter not being correctly set for urban empirical models.
- Fixed a bug that resulted in slightly incorrect coherently superposed received power results along a trajectory.

Release Notes: Altair Feko 2018.1.1

50

Altair Feko 2018.1.1 is available with new features, corrections and improvements. This version (2018.1.1) is a patch release and it should be applied to an existing 2018 installation.

This chapter covers the following:

- [Feko 2018.1.1 Release Notes](#) (p. 393)
- [WinProp 2018.1.1 Release Notes](#) (p. 395)

Feko 2018.1.1 Release Notes

The most notable extensions and improvements to Feko are listed by component.

CADFEKO

Resolved Issues

- Upgrading the meshing library to the latest version brings the following improvements:
 - Resolved a crash that occurred when attempting to mesh a parabolic surface with complex cut-outs.
 - Improved meshing of complex periodic surfaces.
 - Meshing is less sensitive to model extents settings and less likely to yield intersecting triangles.
 - Meshing is less likely to yield multiple sliver triangles around curvature.

POSTFEKO

Resolved Issues

- Corrected the parameter sweep plugin handling of continuous axis data sampling (frequency and far field). The specified number of samples are now taken into account.
- Corrected a problem with the visualisation of wire currents in the 3D view. The bug could have resulted in wire currents not being displayed on the wires when zooming out the display.

Solver

Features

- Support power scaling for FEM line current sources.
- Achieved further memory savings by expanding shared memory usage to other phases. By using shared memory for the Legendre polynomial, memory savings are seen for models with large far field requests that are solved with MLFMM using many cores.
- Improved text output given when rays are discarded during RL-GO calculation.
- Improved the percentage progress output during the geometrical processing phase.

Resolved Issues

- Improved efficient calculation of triangle integrals for FEM/MoM interfaces.
- Improved the passivity checks for anisotropic 3D material by making it more tolerant to numerical uncertainty and inaccuracies.
- Corrected a problem where rays were not exported for RL-GO simulations that utilise the GPU.

- Fixed a bug that caused an error state when there is not enough space available on temporary storage devices during MLFMM runs.
- Fixed a bug that caused an internal error condition when running MoM PBC examples that contain SEP regions together with waveguide ports.
- Fixed a bug that caused an internal error for PBC problems where dielectrics are entirely enclosed in metal.
- Support MPI-3 shared memory on HPE-MPT (formally SGI-MPT) systems.
- Fixed a bug that caused an internal error state after Feko is done with a simulation.
- Significantly improved MoM matrix element calculation when the volume equivalence principle is used.
- Corrected an error in the logic to read and write the `.lud` file for models with multiple configurations.
- Issue an explicit error when PO is used with curvilinear triangles.
- Improved the cleanup process of temporary files for simulations running on multiple hosts by cleaning up on all hosts and not just the master.
- Relaxed the tolerance used to determine if a curvilinear triangle is lying vertically (normal to the XY plane).
- Improved the output message when intersecting elements are found.
- Refined tolerances used for various geometry checks.
- Improved the text for note 33644. The note now reads: "Single frequency inside a loop over angles of plane wave incidence will terminate the loop over angles due to backwards compatibility reasons and processing continues".

Support Components

Features

- Nastran mesh files with missing coordinate information resulted in an error, but will now rather produce a warning and continue with the import assuming the default coordinate system.

Resolved Issues

- Improved handling of MS-MPI command line options.
- The output file of a continuous frequency simulation interrupted by the user only contained converged data. The discrete data are now written irrespective of the convergence status so that users have access to the simulation results that have completed.
- Corrected a problem that could have resulted in the Feko Terminal window not displaying the correct version in the window title.
- Improved ADAPTFEKO argument handling to make it more robust with respect to the order of arguments.
- Corrected a problem with generating `.fek` file format 161 files with a PREFEKO that generates format 162 by default.

WinProp 2018.1.1 Release Notes

The most notable extensions and improvements to WinProp are listed by component.

General

Resolved Issues

- Fixed a license problem encountered with OptMan.

ProMan

Features

- Enhanced the command line options.
 - The `-a` option runs all computations that have been defined (RunPro, RunMS and RunNet):
`ProMan.exe "C:\SampleProject.net" -a`
 - Added a new `-m` option that launches RunMS:
`ProMan.exe "C:\SampleProject.net" -m`
- Added a new solution method for rural scenarios, namely the Rural Ray Tracing (RRT) method. Usually, in rural scenarios, the topography is described by pixels, and solution methods are limited to empirical methods and the dominant path method (DPM). In WallMan, pixel-based topography data can be converted to a geometry described by triangles. A building database can be added during this conversion. Then, in ProMan, deterministic ray tracing is possible. Two methods are available for rural topographies described by triangles: RRT, which operates in the vertical plane, and 3D ray tracing. RRT has the advantage of speed over 3D ray tracing.
- The maximum number of parallel threads within one machine is increased to 256.

Resolved Issues

- Fixed a bug that caused wrong results for the dominant path model (DPM) in combined network planning (CNP) mode (hybrid urban/indoor) with automatic floor management. Transmission losses through floors were not always taken into account correctly.
- Fixed a licence problem with UWB network planning projects.
- Fixed a regression that prevented the display of indoor results in hybrid urban-indoor (CNP) scenarios.
- Fixed a crash that occurred in ProMan when viewing a particular result (number of streams in Network Planning) in one of the example projects.
- For ray tracing over topo triangles, the GUI has been made more user friendly. Absolute height can now be defined for Tx in addition to height above local ground; the maximum size for scatter tiles has been increased (important in large scenarios), and several display inconveniences have been taken care of.
- Fixed a regression in which newly-created polygons with the Paint tool could not be closed.

- Reduced the memory requirements of simulations that combine a large pre-processed geometry database with a measurement-based calibration file.
- Re-enabled the option to display rays inside the indoor part of a combined network planning (CNP) (hybrid urban/indoor) project.
- Fixed a bug in reading the header of the ray file in a solved model with components.
- Fixed a problem that could cause rays in rural scenarios with the dominant path model (DPM) to appear as if they cross through the topology. This behaviour was caused by adaptive resolution management and subsequent interpolation. Propagation results for received power were still correct.
- Fixed a post-processing setting (to fill in pixels that were not computed by IRT) for urban IRT simulations. Slight differences could be observed in results for filled in pixels, depending on whether indoor penetration was active.
- Fixed a bug in which the ZIP archive for a project would not include the `.emc` file (in the relatively rare case that there was one).
- In one of the example models (CampusCNP_IRT), ProMan would hang when the user selected the received power to be displayed. This is fixed.
- Fixed a crash that could occur when combining an urban intelligent ray tracing (IRT) model with a calibration file.
- Fixed a crash that occurred in results display in one of the example models (Car2Car Sample).
- Fixed a crash that could occur during an urban intelligent ray tracing (IRT) simulation if the user cancelled a simulation in progress.

WallMan

Resolved Issues

- Fixed a regression in the topo converter for MSI Planet.

AMan

Resolved Issues

- Fixed one bug that prevented `.ffe` files (far field patterns) produced by AMan to be used in Feko. Those files would already work correctly in ProMan.

Application Programming Interface

Resolved Issues

- Added a missing license check-in during execution of the API. The missing check-in could result in two licenses being checked out.

Release Notes: Altair Feko 2018.1

51

Altair Feko 2018.1 is available with new features, corrections and improvements. It can be applied as an upgrade to an existing 2018 installation, or it can be installed without first installing Altair Feko 2018.

This chapter covers the following:

- [Highlights of the 2018.1 release](#) (p. 398)
- [Feko 2018.1 Release Notes](#) (p. 400)
- [WinProp 2018.1 Release Notes](#) (p. 404)

Highlights of the 2018.1 release

The most notable extensions and improvements to Feko and WinProp in the 2018.1 release.

Salient Features

- The restrictions for cable height above ground are lifted for differentially driven cable problems. The user needs to define the orientation of any cable that does not have nearby geometry by specifying the cable's reference direction.

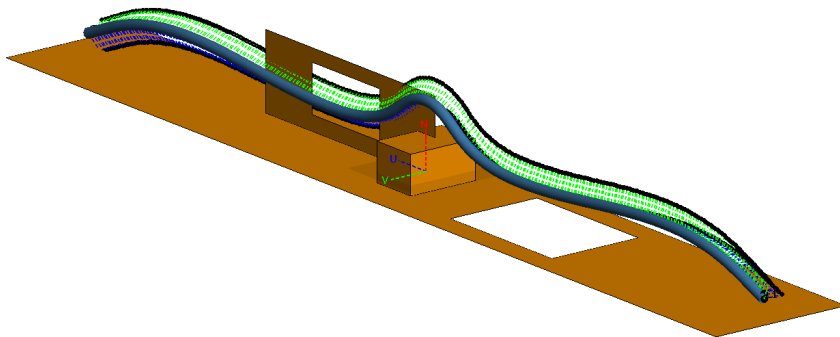

Figure 79: A preview of the cable cross-section orientation of a cable running above an arbitrary ground installation.

- GPU acceleration of flat PEC RL-GO models with manual ray-launching increment settings. Acceleration of up to 40 times faster can be achieved.
- Further memory savings using shared memory technology. The savings are model and solution method dependent with the most prominent savings observed for PO. The PO solution of currents due to a dipole source on a generic aircraft discretised into 1.95 million triangles showed a memory reduction of more than 30% when using 20 cores on a single CPU.
- A new direct ACA solver that is the default for ACA. Memory savings are model dependent with some examples showing up to a 90% reduction in the memory requirement.
- FEM is supported together with MoM/MLFMM windscreen solutions and planar multilayer substrates. Utilising FEM in parts of a model where it is more applicable than the MoM may provide substantial memory and runtime improvements. A representative example of an antenna module in a car with windscreen showed a reduction in memory and runtime of 80%.

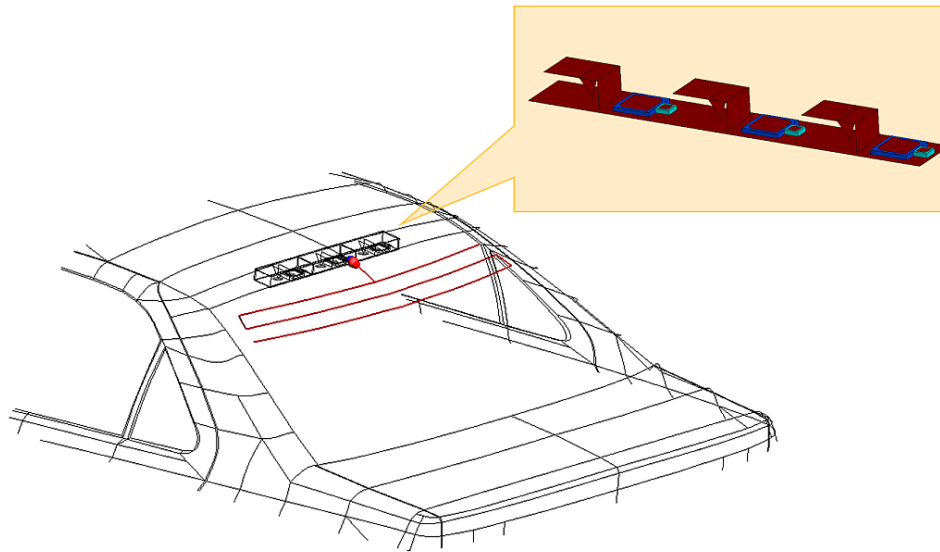

Figure 80: Partial view of a car with a windscreen antenna solved with the MoM/MLFMM and an antenna module mounted in the car's roof (shown enlarged in the insert) solved with the FEM.

- General improvements to the interface when working with Gerber files and to Gerber file export. Arbitrary file extensions are supported for Gerber import. Gerber exports are improved to handle more complex meshed planar geometry.

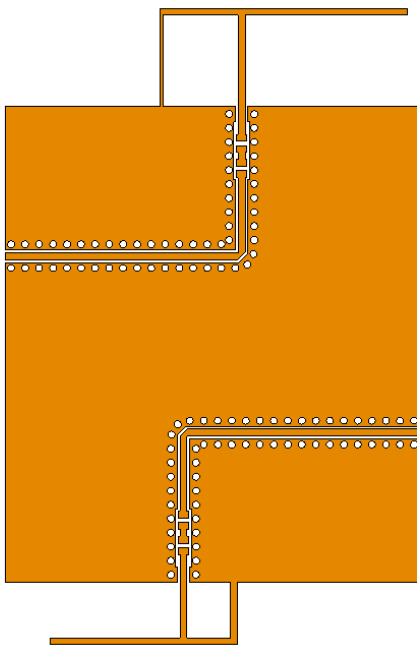

Figure 81: View of an exported Gerber file of a planar antenna with via holes.

Feko 2018.1 Release Notes

The most notable extensions and improvements to Feko, listed by component.

CADFEKO

Features

- All files (*.*) are now displayed in the file browser when importing geometry and selecting to import a Gerber file. The standard Gerber file extension is `.gbr`, but in practice, various other extensions are in use. The extensions that were supported in the previous version of CADFEKO (`.art`, `.gbr`, `.bml`, `.bot`, `.bps`, `.bsk`, `.gnd`, `.tmk`, `.top`, `.tps` and `.tsk`) are still shown in the file browser with other known CAD model files. Files with extensions like `.cmp`, `.ger`, `.gbl`, `.gtl`, `.sol`, and other custom extensions, can be imported by selecting "Gerber" as the file format. These files no longer have to be renamed to a known extension before import. The requirement holds that the files need to be in extended Gerber (RS274X) format.
- The CEM validate check for valid FDTD requests is updated to support a looped plane wave source together with FDTD.

Resolved Issues

- Gerber export now works for meshes of geometry faces that include cut-outs. Exporting to Gerber file did not recognise the cut-outs and for successful export, geometry had to be modified so that there was no hole in any single face.
- Files created in the Feko temporary directory during Gerber and ODB++ import could cause the import to fail if files with the intended temporary file names already existed. The import process now uses temporary folders with unique file names inside the Feko temporary directory. CADFEKO deletes these folders once the import completes or if the user cancels the import.
- Resolved a crash that could occur when applying changes to a huge model.
- Corrected the macro recording of actions performed on a primitive part inside a union to reference the parent union.
- Resolved an assertion failure with message ending in "`m_dataOperatorMap.contains(pData.get())`". This assertion could fail in CADFEKO 2018.0.2 when modifying a port in a model where meshes containing ports were previously merged and undo/redo operations were applied.
- Improved the meshing of some spiral structures to mesh more accurately around the centre of the spiral.
- Corrected the optimisation goal dialogs to list only valid operations when modifying optimisation goals. For example, the **Modify impedance goal** dialog incorrectly included the option to use "`dB`".
- Changed the behaviour when importing points from a text file to skip empty lines instead of only reading up to the first blank line. An assertion failed in "`ImportCsvDriver.cpp`" when trying to import points from a text file starting with an empty line.
- Fixed an assertion failure in "`common_SchematicNet.cpp`" that could occur when importing a `.cfx` file containing connected schematic elements. This assertion failure could also occur when deleting

a connection between rotated schematic elements, saving the model and selecting to undo past the point of saving.

- Opening the properties of a single mesh label and applying without changes resulted in the removal of the simulation mesh, the display of the message `Setting mesh label properties` in the message window and a comment recorded during macro recording. Applying no modification to a single mesh entity no longer removes the mesh or prints out these messages. Simultaneously applying no changes to the properties of more than one mesh entity with clashing settings still deletes the mesh and reapplies the settings.

EDITFEKO

Features

- Added the SD card for defining cable shield layers. The SD card definitions are used in an SH card when creating a single or double shield. The existing Solid (Schelkunoff), Braided (Kley) and Braided (Vance) definitions are available on the SD card. New Tyni and Demoulin formulations are available, or the shield transfer capacitance can be specified.
- Changed the SH card to support single and double cable shields using SD card shield definitions.
- Extended the method to define cable shield properties on the SD card (previously found on the SH card) to specify interpolation methods and extended the surface impedance options to define data points manually or to use a low-frequency braid approximation.

POSTFEKO

Resolved Issues

- Fixed a crash that could occur when exporting tables containing datasets to `.mat` file and improved validation to prevent the export of invalid or unsupported data types.
- Improved the adaptive frequency sampling for POSTFEKO frequency to time domain conversion.
- Corrected the normalisation and improved validation for Touchstone exports. Y-parameters and Z-parameters are normalised correctly. Newly introduced validation prevents the export of Y-parameters and Z-parameters when the reference impedance is unknown, or if ports have incompatible reference impedances. Results are not normalised when exporting S-parameters for ports without reference impedances, such as FEM modal ports.
- Changed the way the 3D view legend handles individual ranges and rounding to prevent the misinterpretation of results. When a dynamic range is specified, and legend rounding is switched on, going forward, the legend may use a range exceeding the specified range. The display now remains unchanged when changing from the "Specify dynamic range" setting to a "Fixed range" and entering the legend settings displayed in the 3D view for the "Specify dynamic range" option.
- Fixed cursor table column spacing and improved the accuracy of displayed values.

Solver

Features

- Support GPU acceleration for flat PEC RL-GO models with manual ray-launching increment settings.
- Reduced memory usage for MoM, MLFMM, PO and LE-PO problems run in parallel where some processes share a node (shared memory).
- Support waveguide ports on MoM regions for the uncoupled MoM/RL-GO hybrid method.
- Support elliptically polarised plane wave source for the RL-GO solution method.
- Cable height above ground restrictions are lifted for differentially driven cable problems.
- Support surface impedance and different frequency ranges for transfer impedance, surface impedance and transfer admittance in cable shield definitions imported from `.xml` file.
- Support cable shields defined by transfer capacitance.
- Support different interpolation methods for cable shield impedance and admittance data.
- Support manually specified cable shield surface impedance.
- Support a low-frequency braid approximation for cable shield surface impedance.
- Support modelling double shielded cables directly.
- Support Tyni and Demoulin formulations for transfer and surface impedance and transfer admittance in cable shield modelling.
- Support the sequential direct LU decomposition solution technique for ACA.
- Select the direct solver for ACA problems by default. Previously the iterative solver was used.
- Support monostatic RCS calculation in a loop for the FDTD.
- Support FEM together with MoM/MLFMM windscreen solutions and planar multilayer substrates.

Resolved Issues

- Bypassed a bug in a maths library used on AVX-512 systems that caused a floating point exception during the iterative solution phase of the MLFMM.
- Significant performance improvement for MoM PBC matrix fill.
- Improved the robustness of the solution of MoM PBC problems when the direction of incidence is at $\theta=90$.
- Improved the robustness for RL-GO curvilinear triangle ray intersection tests.
- Improved RL-GO low accuracy results for incident waves close to grazing incidence.
- Improved automatic convergence for adaptive ray-launching for RL-GO.
- Fixed a cable meshing bug that caused small features to be distorted.
- Avoid internal error 38719 by improving the calculation of surface impedance for braided cable shields.
- Fixed a bug that caused sporadic Intel MPI Hydra errors on parallel Windows systems.
- Fixed an internal error state when calculating the far fields with UTD due to a spherical mode source defined with a very large number of modes.
- Fixed a bug that caused in internal error state when printing out RL-GO ray statistics when there are zero rays generated.

- Improved error checking for problems where TR coefficients are extracted with an RL-GO surface together with the multilayer substrate formulation.
- Improved the Touchstone file import correctness check for reference impedance values set to zero.
- Improved error messages that occur during cable shield braid setup.
- Added geometry intersection tests for cable paths and wire segments with planar triangles.
- Fixed a bug that caused the electric charge distribution to be unsymmetrical for FEM problems where an electrical plane of symmetry is used.

Support Components

Features

- Improved error messages when importing external Feko data files such as `.tr`, `.ffe`, `.efe` and `.hfe` (PREFEKO).

Resolved Issues

- Fixed a bug that reported the runtime incorrectly for continuous frequency solutions (ADAPTFEKO).
- Added firewall exceptions for the MPI Hydra service to the installation process when running it as an administrator.
- Changed the console mode installation to have automatic updates turned on by default.
- Added an example to the Feko Examples Guide that demonstrates the use of the characterised surfaces feature with RL-GO for efficiently solving a frequency selective surface.

WinProp 2018.1 Release Notes

The most notable extensions and improvements to WinProp, listed by component.

ProMan

Features

- Added the ability to compute and present a new class of results, elevation angles and spreads, in addition to the already existing azimuth angles and spreads.
- When viewing field or power results, ProMan will, from now on, ask only once per session whether to load available ray paths.

Resolved Issues

- Fixed a bug that could lead to different results for received power in RunMS depending on whether a channel matrix entry is selected as output or not.
- Fixed a bug in the superpositions of ray contributions in the received-power calculation (RunMS).
- Fixed a bug where, in "PostProcessing incl. Tx and Rx", the transmitter antenna pattern was not considered.
- Fixed a bug in the power superposition for rays in Standard Ray Tracing with Fresnel/UTD coefficients.
- Fixed a bug that prevented the channel condition number from being computed in the previous update, 2018.0.2.
- Fixed a bug that, on some systems, caused the **3D** button that toggles the 3D display to be greyed out in rural scenarios.

Application Programming Interface

Resolved Issues

- Added capabilities to the WinProp API for handling vegetation and clutter in outdoor scenarios. In doing so, backward capability for outdoor clutter in the API could not always be maintained.

Release Notes: Altair Feko 2018.0.2

52

Altair Feko 2018.0.2 is available with new features, corrections and improvements. This version (2018.0.2) is a patch release and it should be applied to an existing 2018 installation.

This chapter covers the following:

- [Feko 2018.0.2 Release Notes](#) (p. 406)
- [WinProp 2018.0.2 Release Notes](#) (p. 409)

Feko 2018.0.2 Release Notes

The most notable extensions and improvements to Feko are listed by component.

CADFEKO

Resolved Issues

- The thickness of metal faces gets imported from `.fek` files.
- Ports are no longer removed when merging meshes.
- Some problematic CAD faces could have resulted in an assertion failure with the message `"! errorInfo.needsRollback()"` when snapping in the 3D view or querying the centre of gravity of such a face through the API. The 3D view is now functional even when such faces are present, and an error gets issued in the scripting environment when it is not possible to calculate the centre of gravity.
- Resolved an issue that prevented changing the face solution properties of a face labelled "Face0". The problem presented when creating a cone or flare primitive with the top dimension set to zero and then modifying this dimension to be non-zero.
- A problem is fixed that caused an assertion to fail with "Current active state widget SpecifyPointsImportPointsButton doesn't have focus and should be visible" when pressing Tab or Shift+Tab repeatedly on certain dialogs, such as the **Create dielectric medium** dialog.
- Inactive waveguide ports were handled incorrectly for S-parameter configurations, causing `Warning 33046: Possibly wrong use of the specification "additional" for a source, please verify active sources during simulation.` This is corrected.
- Meshing a model directly after excluding or including a configuration takes all included configurations into account with immediate effect. Before, it was required to mesh a second time or to make other changes to the model before the settings took effect.
- Prevented an assertion failure with the message `"simulationMeshCollector.getGraphNodeNodes().size() == 1"`. Upon opening a model that issues `Warning 16889: GeometryPart has more than one linked mesh. This can cause problems and/or the application to close unexpectedly.,` all but one of the linked meshes are now deleted to prevent further problems.
- Resolved a crash and assertion failure with message `"m_modelBoxDiagonal > 0.0"` that could occur when meshing some models.
- A model saved with no 3D view would open with the default 3D view of the model. It now re-opens as it was saved, without a 3D view open. Closing the 3D view provides an alternative to hiding elements from the view for improved performance when working with complex models.
- Improved the intersecting triangle algorithm.
- Selecting an individual segment highlighted the whole wire in the 3D view. Highlighting is corrected for the selection of individual segments when using wire display with surface display disabled.
- The region, face or edge properties of a geometry part opened and applied without changes resulted in the removal of the mesh and printed the message `Changed settings for geometry entities` to the message window. Macro recording recorded this action as a comment. Applying no changes no longer removes the mesh or prints out these messages.

- Suppressed a Parasolid error that caused a geometry modeller problem during meshing or an assertion failure when meshing with the FDTD solver active.

EDITFEKO

Resolved Issues

- Resolved a crash that could occur when entering text in the search bar and pressing a modifier key like Ctrl.

POSTFEKO

Resolved Issues

- Improved the placement of cursor text boxes on 2D graphs to avoid overlap and to remain visible inside the graph area.
- Resolved an assertion failure in "DataSetExporter" that were triggered when reading fields through scripting if a plane wave source was set to calculate the orthogonal polarisations.
- The result for the orthogonal polarisation of a single incident plane wave is now available. This result was unavailable for a far field result calculated in the plane wave incident direction when the plane wave set to **Calculate orthogonal polarisations** was defined in a single direction only.
- Fixed an assertion failure that terminated the application with "Assertion failed: Manager was never set, i.e. nothing was assigned to: Position" when storing combined receiving antenna data.
- A problem is fixed that caused an assertion to fail with "Current active state widget SpecifyPointsImportPointsButton doesn't have focus and should be visible" when pressing Tab or Shift+Tab repeatedly on certain dialogs, such as the **Create time signal** dialog.

Solver

Resolved Issues

- Improved insufficient memory allocation errors reported by external libraries.
- Introduced an error to prevent the simulation of any cable path terminated by a load, source or interconnect connection onto itself.
- Fixed a bug that caused certain cable problems solved in parallel using the combined MoM/MTL method to end in the error state 52695.
- Fixed a bug that caused incorrect receive power to be reported when a highly directional receive antenna is modelled using spherical modes and rotated within the model.
- Improved the stability of triangle intersection checks for triangles that touch at a single point.
- Fixed a bug that caused an internal error state to be issued during geometry checking for CFIE models where the surface touches itself on an edge.
- Fixed a bug that caused very large symmetrical MoM problems to appear to hang when solved in parallel.

- Fixed a bug that caused a parallel deadlock for models that contain cable problems and connection points with current sources on MoM problems.
- Fixed a sporadic floating point error when calculating the ACA H-matrix.
- Fixed a bug that caused closed CFIE geometries with internal surfaces touching on edges only to report an error.

Support Components

Resolved Issues

- The model for example D02 (Calculating Field Coupling into a Shielded Cable) is corrected to use local ground connections on the cable schematic to terminate the cable start and end connectors. Simulation of the model issued `Warning 38926: A SPICE interconnect circuit applied to a cable harness has connectors separated by more than 5% of the total harness length. The simulation results were correct in this case, but it is not generally advised to set up a model in this way. Error 52712: A cable path should not be terminated by a load/source/interconnect connection onto itself` is now issued when cable connectors are connected through the global ground.

WinProp 2018.0.2 Release Notes

The most notable extensions and improvements to WinProp are listed by component.

ProMan

Features

- The polarimetric analysis capability has been completed. This new capability, which one selects at the beginning of a new project, is available for indoor and urban scenarios. It requires an antenna pattern from Feko in `.ffe` format, since this format contains all field components for every individual direction. For simulation, standard ray tracing or intelligent ray tracing, with the use of Fresnel/UTD coefficients, is recommended. The standard (non-polarimetric) capability can be selected for any scenario and any simulation method at the beginning of a project. It should be mentioned that one can always use Feko antenna patterns in `.ffe` format. However, in the standard work flow, no attempt is made to extract polarization-specific information from the antenna pattern, as for many permitted formats this is simply not part of the file. In the standard work flow, one can still specify the predominant antenna polarization and the cross-polarization level, both for transmitting and receiving antennas. The difference is that such polarization information in the standard analysis applies to all directions in the antenna pattern.

Resolved Issues

- Fixed a bug that resulted, for selected indoor scenarios, in longer simulation times in version 2018.0.1.
- Fixed a bug where ProMan was using incorrect information from an antenna pattern in Feko `.ffe` format when it was used in a non-polarimetric (standard) analysis. ProMan was using the vertically polarized fields instead of the total fields in that particular case.
- Fixed a crash that could occur in MIMO post processing due to a bug in the computation of the condition number.
- Fixed a crash that could be triggered by an unusual sequence of user actions.
- Fixed a crash that could occur when using the "Additional Data" menu with a topological database loaded.

WallMan

Resolved Issues

- Fixed a crash that could occur when pre-processing of a database was cancelled.
- Fixed a bug related to DWG/DXF import of 2D CAD data. A window that enables the user to define wall height (used by WallMan to extrude the 2D data) did not appear.
- Fixed a crash that occurred during pre-processing of a particular database.
- Modified a default setting. During pre-processing, by default adaptive resolution management used to be activated. As a consequence, in ProMan during RunMS, for some pixels no results might be

computed, which would raise concerns. With the new default setting, one always obtains results for all pixels.

- Fixed a crash that could occur during pre-processing of an urban database.
- Fixed a bug that could cause a “read access violation” when the user pressed the Cancel button during pre-processing.
- Fixed a bug that limited WallMan's pre-processing to one database. To handle a second database, one needed to start a new instance of WallMan.

Application Programming Interface

Resolved Issues

- Fixed an “access violation” in the WinProp API.

Release Notes: Altair Feko 2018.0.1

53

Altair Feko 2018.0.1 is available with new features, corrections and improvements. This version (2018.0.1) is a patch release and it should be applied to an existing 2018 installation.

This chapter covers the following:

- [Feko 2018.0.1 Release Notes](#) (p. 412)
- [WinProp 2018.0.1 Release Notes](#) (p. 414)

Feko 2018.0.1 Release Notes

The most notable extensions and improvements to Feko are listed by component.

POSTFEKO

Resolved Issues

- The DerivedResults module is corrected to support phi axis ranges. Using the module to calculate results from data with phi values could have resulted in an error. This is now also fixed for Ludwig III (Co) and Ludwig III (Cross) components.
- Improved the adaptive algorithm used to interpolate and extrapolate frequency responses during the frequency to time domain transformation in POSTFEKO.

Solver

Features

- Improved solution time when calculating per-unit-length cable parameters for cable solutions.
- Optimised memory usage for the fast far field calculation for discrete frequency models.

Resolved Issues

- Fixed a bug that caused the solver to hang in exceptional cases when parallel processes write CMA data to CMA files.
- Improved the accuracy of the phase when using physical optics for models with thin dielectric sheets or coatings when the sheets/coatings become thick.
- Fixed a bug that caused near field to spherical mode transformation to fail if the field complexity requires a high level of recursion.
- Fixed a bug that caused an incorrect error stating that the normal vector orientation is not correct for certain windscreen antenna problems.
- Fixed a bug that caused cable results to differ depending on the order of signal number specification.
- Fixed a bug that caused intersecting triangle errors for certain models meshed using lower precision.
- Improved general memory usage.
- Allow transmission and reflection coefficients to be calculated for incident waves that are parallel to the surface of PBC structures and Green's function planes.
- Fixed a bug that caused an internal error state when circular/coaxial waveguide ports were used together with rectangular waveguide ports.
- Improved flushing cache files (STR/PUL) in between frequency points.
- Fixed a bug that reported negative percentage output when using the MLFMM to calculate certain problems.

- Improved the power loss calculation per medium for cable calculations - total losses stays unchanged.
- Relax geometry intersection check tolerances to allow certain valid geometry.
- Fixed a bug that could influence the performance of some SPAI preconditioned parallel iterative solution.
- Improved error reporting for models that contain faulty triangles.
- Improved memory usage and reporting for parallel MLFMM and MoM problems.
- Improved time usage reporting for tracked CMA problems.
- Fixed a bug that caused an error state for PBC examples that had edges defined on the corners of the PBC cell.
- Improved accuracy of memory usage reporting.
- Fixed a bug that caused an incorrect error stating that a curvilinear triangle is malformed.
- Fixed a bug that caused Feko initialisation to abort if environment variables contain illegal characters.

Support Components

Resolved Issues

- Support multiple frequency blocks when importing near fields (.efe/.hfe).
- Multiple instances of the Feko + WinProp Launcher utility can be open at the same time to launch components from different installations.
- Minor corrections to the User Guide include the correction of the file formats in the section "Defining Near Field Data from File".

WinProp 2018.0.1 Release Notes

The most notable extensions and improvements to WinProp are listed by component.

General

Resolved Issues

- Added support for floating licenses to the 2018 WinProp Student Version to bring it in line with the 2018 Feko Student Version.
- Fixed a bug that sometimes prevented TuMan files created under Windows 10 to open under Windows 7. There was an initialisation that is done automatically on newer operating systems and not automatically on Windows 7.
- Fixed a bug in AMan where binary files were produced that couldn't be read later.
- Enhanced the flexibility of AMan to read antenna patterns with angles beyond 180 degrees.
- Fixed a crash in the API that occurred when results for multiple heights were requested.

ProMan

Features

- For simulations with empirical methods, in addition to defining a polarization for the transmitter, the user can define a cross-polarization level.

Resolved Issues

- In a network planning run that was performed after including the pattern of the mobile station via RunMS, sometimes the wrong receiver power values were used, leading to incorrect data rates. This has been fixed.
- Fixed a bug where the option of multi-threading for standard ray tracing was not respected.
- Prevented a race condition from occurring when multiple threads read the same antenna-pattern file.
- Fixed a crash that could occur when an invalid file is selected to define a satellite transmitter. Now an appropriate error message is displayed.
- Fixed an error given in certain simulations involving the dominant path model with Fresnel coefficients.
- Fixed a problem with computational efficiency for the dominant path model (DPM). This problem had caused simulations with DPM to be slower than expected.
- Fixed a case in which the computation dialog couldn't be closed after cancelling a simulation.
- In cases where the user had defined a directory name other than the default for RunMS results, problems could occur later during network planning, as the new name was not always passed on. This has been fixed.
- Fixed a bug that could lead to the wrong display of transmitter orientation.

- Fixed a bug that had disabled one route of importing measurement files.
- Added the option to display ray interaction points in 3D with smaller dots than the default. They could sometimes be a bit large.
- Fixed a crash that could occur in ProMan when invalid data were loaded in addition to topographical data.
- Fixed a bug that could cause a crash when displaying all propagation paths.
- Fixed a crash in viewing impulse response results on Windows 7.

WallMan

Resolved Issues

- A bug has been fixed that prevented the conversion of certain topographical maps that crossed the equator.
- In WallMan, a rare endless loop that could occur during pre-processing for IRT has been fixed.
- Fixed a few issues related to HyperWorks licensing, such as a license being checked back in prematurely after preprocessing in WallMan.
- Fixed a problem with a missing DLL that caused WallMan to crash on Windows 7. This didn't happen for every Windows 7 installation since often other installed software tools already provided the DLL.

WinProp CompoMan

Resolved Issues

- Fixed a crash in CompoMan.

Altair Feko 2018 is available with a long list of new features, corrections and improvements. Altair Feko 2018 is a major release. It can be installed alongside other instances of Altair Feko.

This chapter covers the following:

- [Highlights of the 2018 release](#) (p. 417)
- [Feko 2018 Release Notes](#) (p. 422)
- [WinProp 2018 Release Notes](#) (p. 431)

Altair® Feko® is a comprehensive computational electromagnetics (CEM) software used widely in the telecommunications, automobile, aerospace and defence industries.

Feko offers several frequency and time domain electromagnetic (EM) solvers under a single license. Hybridisation of these methods enables the efficient solution of a broad spectrum of EM problems including analyses of antennas, microstrip circuits, RF components and biomedical systems, placement of antennas on electrically large structures, calculating scattering effects and performing electromagnetic compatibility (EMC) studies.

WinProp is the most complete suite of tools in the domain of wireless propagation and radio network planning. With applications ranging from satellite to terrestrial, from rural via urban to indoor radio links, WinProp's innovative wave propagation models combine accuracy with short computation time.

Highlights of the 2018 release

The most notable extensions to Feko and WinProp in the 2018 release.

Features

- WinProp is included as part of the Feko HyperWorks installation. WinProp is a leading software for wireless propagation modelling and radio network planning. It interfaces with Feko through the import of Feko `.ffe` far field patterns. The legacy licensed Feko installation does not include WinProp and a legacy licensed WinProp installation is available.
- A new **Feko + WinProp** Launcher utility reduces the number of icons added to the Windows start menu. This utility contains options to launch the various Feko and WinProp components. It also provides easy access to the Feko documentation and the Altair licence utility.

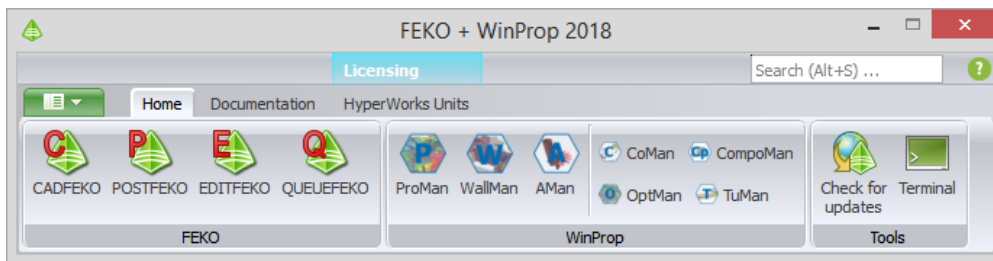

Figure 82: The Feko + WinProp Launcher utility

- Characterised surfaces for the ray launching geometrical optics (RL-GO) solver greatly speeds up RL-GO analysis of complex multilayer structures.

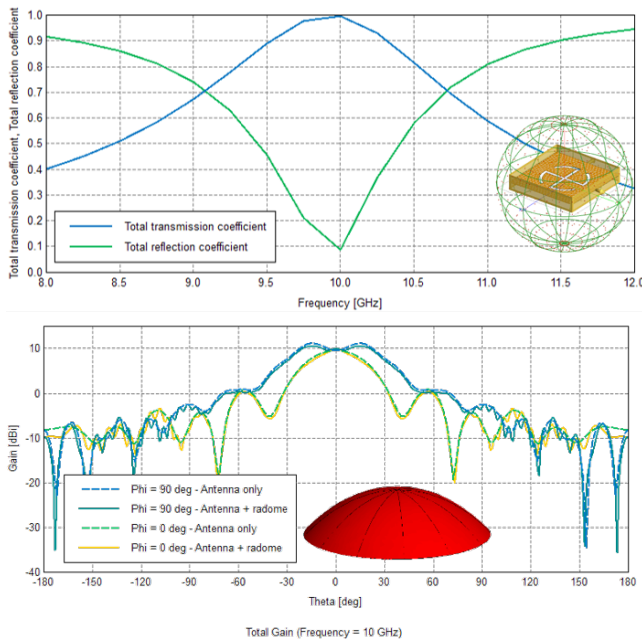

Figure 83: Antenna operating at 10 GHz with FSS radome modelled with a characterised surface. The radome simulation completes within a few minutes.

- The hybrid FEM/MoM supports dielectric objects solved with the surface equivalence principle (SEP) in combination with dielectric objects treated with the finite element method (FEM), provided the regions do not touch. This can reduce the simulation requirements significantly for some applications. The ferrite circulator example below completed in half the runtime, using seven times less RAM than the FEM-only solution.

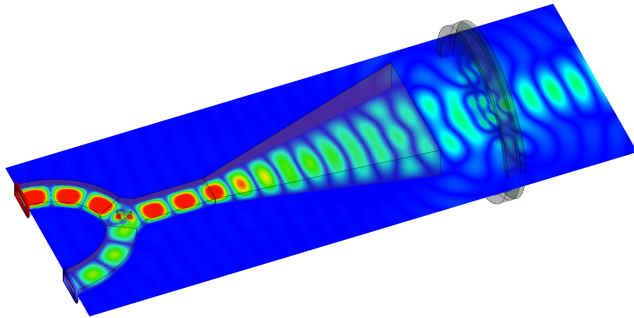

Figure 84: Ferrite circulator (FEM) with horn antenna and dielectric lens (SEP).

- Various cable modelling extensions, including:
 - A reference direction can be defined for a cable path. This provides precise control over cable orientations, instead of letting the solver search for the closest ground to the cable path.

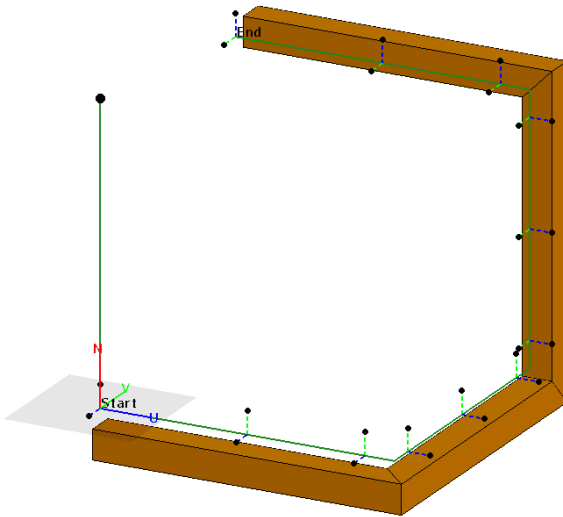

Figure 85: A reference direction can be defined to specify the orientation of a cable.

- Error handling is improved for cables requiring a ground plane.
- A newly developed cable cross section mesh library results in improved cable meshes, especially for cables close to geometry and for closely spaced cable conductors.

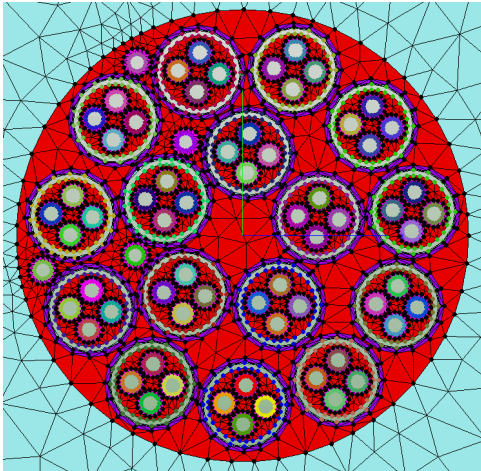

Figure 86: An example of a cable cross section mesh used by the solver.

- N-port Touchstone files can be used as interconnections or terminations of cables.
- HyperSpice is supported as a SPICE solution method for cable and network simulations. This SPICE solver provides a great speedup compared to the NGSPICE solver that is also available in Feko.
- Numerous meshing improvements, including:
 - Automatic meshing (Standard, Fine and Coarse) now yield different meshes for models where the mesh size is governed by the geometry curvature rather than the electromagnetic properties like frequency.
 - Automatic meshing rules for metal faces between dielectric regions are relaxed to be more in line with practical requirements.
 - Many performance enhancements and improvements to the meshes generated by the mesh engine introduced in Feko 2017.
 - A comprehensive check is added to detect overlapping or intersecting triangles when the solver is run.
- Improved DC estimation for time analysis.
- Graphs and displays are updated as adaptive frequency sampling results (results calculated over a continuous frequency range) become available.

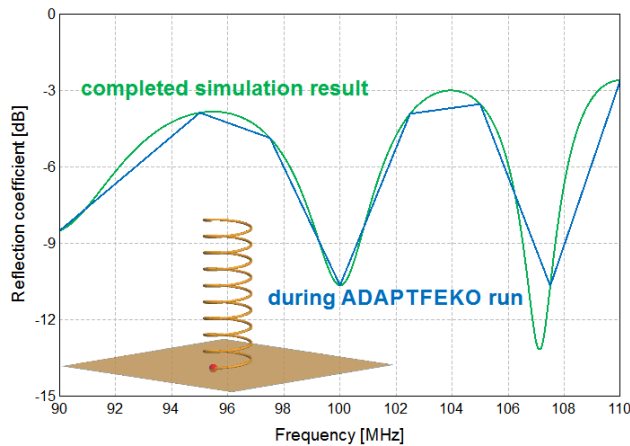

Figure 87: A Cartesian graph with the reflection coefficient of a helix antenna shows the completed continuous frequency result and the discrete result as it gets displayed during simulation.

- Untracked characteristic modes can be displayed in POSTFEKO.

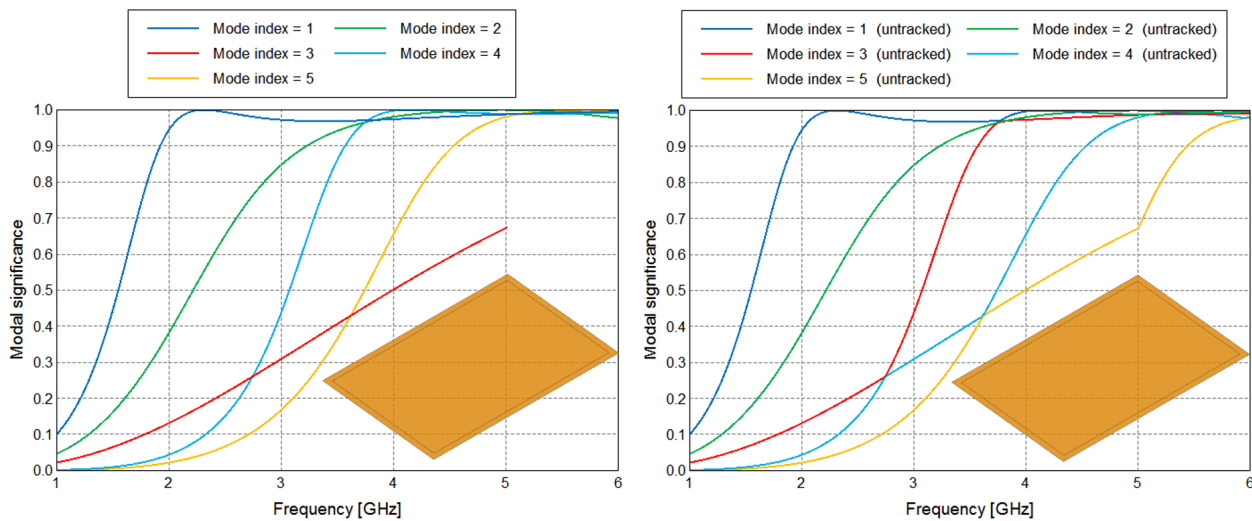

Figure 88: Modal significance plots from a characteristic mode analysis performed on a PEC plate showing tracked modes on the left and untracked results on the right.

- A phase reference point can be set for a plane wave source (before the reference was assumed to be the global origin).
- WinProp extensions include:
 - Full polarimetric analysis through the import of Tx and Rx antenna patterns from Feko. Polarisation can be taken into account in WinProp.
 - Support for the import of OpenStreetMap data (.osm XML files).
 - In Virtual Drive Test, a velocity profile can be defined along the trajectories. The results will include the Doppler shift.
 - WinProp radio channel data can be exported to the ASCII format supported by Keysight PROPSIM.

- Increased user-friendliness through the use of relative paths when archiving antenna patterns and databases. Properties of antenna, sites, transmitters and cells can also be imported from existing WinProp projects, simplifying the setup of similar projects.
- The documentation is reworked with many improvements and changes, including the following:
 - The Feko manuals are incorporated into the HyperWorks help format.
 - The Feko documentation is improved to be more task driven.
 - The Feko User Manual includes more information, for example, a new section lists common errors and warnings that may be encountered.
 - Improved syntax highlighting of code snippets.
 - The location of the help folder is updated to: `c:\Program Files\Altair\2018\help`.

Feko 2018 Release Notes

The most notable extensions and improvements to Feko are listed by component.

CADFEKO

Features

- The CEM validate check for dielectrics in the same model is updated to support FEM together with SEP, provided that the regions do not touch. (2018)
- The plane wave source is extended to support calculating two orthogonal plane wave source polarisations without the requirement to create multiple configurations. (2018)
- Characterised surfaces can be defined and applied to RL-GO faces. (2018)
- Support is added to export transmission / reflection coefficients to .tr file. The request is activated on the transmission / reflection request dialog. (2018)
- The option to specify the return path for ribbon cables is removed. The setting is no longer used and the return path is calculated automatically (either via the ground or via the cable conductors). (2018)
- The orientation of cables can be defined. This provides precise control over the cable orientation instead of letting the solver search for the closest ground to the cable path. (2018)
- Mesh imports are extended to recreate, when possible, the parts and associated faces during the import process. Faces are grouped into parts as they were at the time of export. Imported meshes without labels will be grouped into an "UnknownMeshParts" part. The feature can be disabled to obtain the previous import behaviour yielding parts labelled "MeshImport". (2018)
- Automatic meshing (fine, standard and coarse) now influence the advanced mesh settings for curved geometry approximation (refinement factor and minimum element size). This ensures that the three automatic mesh size options yield different meshes for models where the mesh size is governed by the geometry rather than the electromagnetic properties (like frequency). (2018)
- The meshing library is upgraded to the latest version. (2018)
- The automatic meshing rules for metal faces between two dielectric regions are relaxed. The theoretical meshing requirements are too stringent for most practical simulations. A compromise between the theoretical required meshing and required resources that still provides good simulation accuracy is implemented. (2018)
- The CADFEKO API is extended to return a list of parts that are imported. This change breaks backwards compatibility and may require users to update their scripts that use the return value. (2018)
- The CAD import library is upgraded to provide access to the latest CAD formats and to benefit from the latest bug fixes and performance improvements. (2018)

Resolved Issues

- The calculation of the size of the FDTD boundary box is corrected for the option to specify the size of the free space buffer in the X-direction (+X or -X). (2018)

- A problem with periodic boundary condition meshing is resolved, where for some models, the geometry modeller encountered a problem and the mesher aborted abnormally. (2018)
- The order of some cards in the `.pre` file was not written out consistently. This could lead to the solver detecting changes in the model, preventing the `.str` file to be used for subsequent calculations. This is corrected. (2018)
- The dialog for exporting a model to Parasolid format is updated to allow exporting to the latest versions. (2018)
- An assertion that failed with "Assertion failed: ((*it)->addToHistory())" is resolved. An error, "Scaled model contains faults" will now be triggered when a `.cfx` file is imported and the operation cannot complete due to problems with the required scaling during import. (2018)
- An assertion that failed with "src\cf_ProjectAutomation.cpp (117): Assertion failed: 0" is fixed. This assertion failure could be encountered when importing `.cfx` models created by the Antenna Magus software. (2018)
- Gerber imports could have resulted in imports where some parts were missing. These problems are corrected. (2018)
- Improvements to the Gerber import process prevent some elements from being clipped (trimmed) during the import process. (2018)
- Gerber and ODB++ import offers improved support for folders and files that use unicode characters. (2018)
- The region settings on faces imported from Gerber files could have been set incorrectly during the import process. These region settings are now applied correctly. (2018)
- A mismatch between the model extents and the extents of Gerber or ODB++ files could have resulted in an assert failing during the import process. (2018)
- A correction to the Gerber unit directive resolves a problem that resulted in some entities not being imported into CADFEKO. (2018)
- The Gerber and ODB++ library is upgraded with many improvements implemented with the upgrade. The upgrade includes various bug fixes and enhancements. (2018)
- The problem that required some users to install Microsoft Visual C++ 2008 redistributables before they could import Gerber and ODB++ files is resolved. (2018)
- Script recording is extended to support the import of Gerber, 3Di and ODB++ files. (2018)
- The recorded script when importing a `.fek` file used an undefined "properties" table that resulted in an error when running the script. This is fixed. (2018)
- Script recording is extended to support `.dxf` file import. (2018)
- The algorithm for detecting intersecting triangles is improved. The problem that a different number of intersecting elements gets reported for a model mesh and the same mesh used as simulation mesh is resolved. (2018)
- An error with mesh variable evaluation could have resulted in meshes using the previous mesh setting under very special circumstances. The evaluation bug is fixed. (2018)
- Re-meshing of volume meshes (finite element method) did not correctly take into account embedded metal structures and resulted in non-matching triangle-tetrahedron boundaries. Meshes of model meshes now include the discretisations for internal metallic faces. (2018)

- The meshing quality and the meshing performance for FEM models (volume meshing) are considerably improved. These performance improvements are easily seen when meshing large array structures. (2018)
- Meshing of fine helical structures with curvilinear segments is improved. (2018)
- Automatic meshing is revised to correctly mesh second order elements on FEM-FEM boundaries. First order elements are still created on FEM-MoM boundaries. Faces bounding FEM regions are corrected to use the meshing rules of the FEM region and not the MoM meshing rules. (2018)
- The meshing performance for UTD plates is improved. For large models the resource requirements could have resulted in the meshing process failing. (2018)
- Periodic boundary condition meshing is improved to take into account the effect of wires touching faces on the periodic boundaries. (2018)
- A meshing issue with some problematic faces that could not be meshed is resolved. Warning messages, including the warning "A correct definition could not be recovered", were triggered during meshing. These faces are now meshed correctly. (2018)
- Large volume meshes with fine detail could have resulted in large tetrahedra. The problem is corrected and the tetrahedral element sizes are now consistent. (2018)
- The meshing of spherical geometries is improved. In the past it could happen that some faces of spherical structures were not meshed. This problem is resolved. (2018)
- A wire with a segment and a vertex port in close proximity could have resulted in an assert failing. This case is now correctly taken into account, resulting in an error message or a successful mesh (when meshing is possible). (2018)
- Corrections made to wire re-meshing ensure that the wire mesh settings are taken into account correctly. Some re-meshed wires could have resulted in much fewer segments in previous versions. (2018)
- Small geometry feature suppression during meshing is corrected for models containing wire ports and symmetry planes. Small geometry features are now ignored for the specified percentage of the mesh size. (2018)
- The mesher aborted abnormally when attempting to mesh some analytical curve geometry using curvilinear segments. The geometry now meshes successfully. (2018)
- The meshing of sharply curved hyperbolic arcs are improved. (2018)
- Sinusoidal curve geometries are approximated more accurately when meshing with straight elements. (2018)
- The API is extended to allow the use of interpolation features in result scripts. (2018)
- An assertion that failed with "src/operatorframework/mesh/modifiers/gaia_NonRestorableMeshModifier.cpp (6): Assertion failed: 0" is resolved. This problem could be encountered when attempting to delete parts of a locked model mesh. (2018)
- A crash is resolved that could present when translating a mesh part imported from a `.cfx` file. This was due to the "Use model mesh" setting incorrectly being in an inconsistent state. (2018)
- Many unions that failed in the past now union correctly due to improvements to the union operator. (2018)
- Meshing of wire ports located at the centre of the wire has been corrected to create the wire segment port at the centre of the wire. In some cases the meshing could have resulted in the port being slightly offset. (2018)

EDITFEKO

Features

- The A0 card (plane wave source) is extended to allow users to specify whether the orthogonal plane wave definition should be included in the simulations. (2018)
- The DA card (data output) is extended to allow exporting .tr files (transmission / reflection data from infinite surface structures). (2018)
- The DI card (dielectric and magnetic material definition) is extended to support characterised surface materials. (2018)
- The SK card (skin effect and other surface properties) is extended to allow users to apply characterised surface properties on RL-GO faces. (2018)
- The CS card (cable section) is extended to support cable orientations. The cable orientations are required when no ground plane is available to define the orientation or when the ground plane is electrically far from the cable path. (2018)
- The CD card (cable cross section definition) option to specify the return path number for ribbon cables is removed. This setting is no longer used and the return path is determined automatically (either via the model ground or cable conductors). (2018)
- The CI card (cable interconnect) is extended to support N-port Touchstone interconnections and terminations on cables. (2018)
- Edge loads now take port polarity into account at the LE card. (2018)

Resolved Issues

- Support for the old A4 and L4 cards has been discontinued. These cards have been removed from the interface. (2018)

POSTFEKO

Features

- The adaptive frequency sampling algorithm is used to interpolate and extrapolate frequency responses for time analysis in POSTFEKO. The new algorithm greatly improves the direct current (DC) estimate and this results in better time domain results. The setting can be disabled on the **Time domain** tab in POSTFEKO. (2018)
- Support is added in POSTFEKO to allow loading and displaying models where both orthogonal plane wave polarisations are requested. (2018)
- Support for ray launching geometrical optics (RL-GO) characterised surfaces was added. The characterised surface can be defined and then applied to RL-GO faces. (2018)
- Support is added for N-port Touchstone files to be used as terminations or interconnections for cables. (2018)
- The display of untracked modes from characteristic mode analysis (CMA) simulations is supported. The mode number (for tracked data) or the mode number with "untracked" in parentheses (for untracked data) can be selected on views and plots showing CMA results. (2018)

- Support for surface graph point annotations is added. Quickly add an annotation to a Cartesian surface graph by holding Ctrl+Shift and left mouse clicking on a plot, or specify the horizontal and vertical axes values at the point of interest. (2018)
- The surface graph supports exporting results to a text file for further processing. The results can be exported to the clipboard using the Ctrl+X keyboard shortcut. (2018)
- POSTFEKO monitors simulation results and updates the display and graphs as the results become available for discrete frequency results. This feature is now also available for adaptive frequency sampling results (continuous frequency). POSTFEKO will display the discrete results during the simulation and interpolate the results once the simulation has completed. (2018)
- The `OpenFile` method in the API is changed to open models (`.fek` files) with many mesh elements by default (instead of not loading the mesh). (2018)
- Phase unwrapping support is implemented for receiving antennas. (2018)
- Support is added for changing the unit (V/m versus kV/mm) when displaying results in decibels. (2018)
- The `.fek` file version is increased to 159 to accommodate new cable extensions. (2018)
- The Feko far field file formats are extended to provide the polarisation angle in the block header. (2018)
- Edge loads now take port polarity into account and this is correctly indicated in the 3D view and details tree. (2018)

Resolved Issues

- Improved support was added for importing large data files (larger than 1 GByte). (2018)
- Touchstone impedance and admittance files were incorrectly imported (incorrect normalisation was used) and has been fixed. (2018)
- A display bug is fixed that could have resulted in a crash when setting the segment display radius to zero. (2018)
- Scaling of text on images exported from 3D views are improved. The text size was much smaller on exported images than on the 3D view. The font sizes on images exported with the "Same as source" size setting are now the same as on the 3D view. (2018)
- The display of far field lobes with transparency is corrected. In previous versions, the colours could have changed when using hardware rendering. Software rendering remains correct. (2018)
- Support for an invalid (collapsed) axis definition is improved. Invalid axis definitions could have resulted in an assert failing, but they are now handled correctly in POSTFEKO. (2018)
- The Cartesian surface graph display is extended to support invalid and infinite numbers. The invalid values are ignored, but previously could have resulted in an assert failing. (2018)
- Cartesian surface graphs now support polarisation angle, plane wave theta and plane wave phi as possible independent axes when these are available. An empty combobox was displayed for near field results containing these values and polarisation angle could not be selected as independent axis for far field results. (2018)
- The Cartesian surface graph right click context menu is corrected to be available from anywhere on the plot area. (2018)
- All polar plot annotations with a horizontal position of greater than 180 degrees was shown at 180 degrees. This regression was introduced by changes in POSTFEKO 2017.2.5. It is corrected. (2018)

- The option to change the time signal for a Cartesian graph time analysis trace is now available for S-parameter results, waveguide source data and modal source data. (2018)
- Measurement cursors update correctly for negative horizontal axis values. The problem that was introduced in POSTFEKO 2017.2.5 is resolved. (2018)
- The width of combo box widgets on the ribbon is increased to improve readability of items with longer text. (2018)
- Validation on the API for exporting results was corrected to require a minimum of two points. It was incorrectly possible to export using a single point. (2018)
- The `DerivedResults` module is corrected to support phi axis ranges. Using the module to calculate results from data with phi values could have resulted in an error. (2018)

Solver

Features

- Improve the scaling and robustness of the MoM phase of the coupled FEM/MoM solution method. (2018)
- FEM/MoM problems are supported with SEP dielectric regions, provided that the SEP dielectrics do not touch the FEM/MoM interface. (2018)
- CUDA is upgraded to version 8.0, providing access to the latest enhancements in GPU computing. (2018)
- Higher order waveguide triangle basis functions are pre-calculated, resulting in large performance improvements for waveguide models utilising higher order basis functions. Pre-calculation was already supported for the RWG basis functions. (2018)
- Shared memory is expanded to further phases, resulting in more memory savings for the MLFMM. (2018)
- The number formatting for MLFMM memory usage reports is improved. (2018)
- Exporting near and far field data for orthogonal plane wave sources is supported. (2018)
- Characterised surface definitions can be exported to `.tr` files. (2018)
- Characterised surfaces can be used to speed up RL-GO calculations for surfaces where transmission and reflection coefficients are a function of frequency and direction of source incidence. (2018)
- Support is added to set the plane wave source reference point. The phase reference was always assumed to be the global origin, but now it can be set by the user. (2018)
- Support is added for the phase reference for plane wave sources in the FDTD. (2018)
- N-port Touchstone files can be used as interconnections or terminations of cables. (2018, 2018)
- The error handling for cables requiring a ground plane is improved. The cable height above the ground is tested at the highest frequency. An error is given if the cable is too high above the ground. This error was present in the past, but would often be triggered only after many frequencies have been simulated. (2018)
- A newly developed cable cross section meshing library results in improved cable meshes, especially for cables close to geometry and for closely spaced cable conductors. (2018)

- An environment variable, FEKO_WHICH_CABLE_MESHER, is added to enable the selection of the mesher to be used for cable solutions. (2018)
- HyperSpice is supported as a SPICE solution method for cable and network simulations. Low-frequency cable performance is improved with the addition of this SPICE solver. (2018)
- Edge loads are supported for finite antenna array analysis. (2018)
- The Intel Math Kernel Library (MKL) is upgraded to version 2018.1. The new version shows performance improvements on newer hardware (being able to utilise the latest hardware advancements). (2018)
- Feko is compiled using the latest Intel compilers, allowing it to optimally utilise the latest hardware for the best possible performance. (2018)
- The Windows compilers are upgraded to Microsoft Visual Studio 2015 (service pack 3). (2018)
- The Linux GNU Compiler Collection (GCC) is upgraded to version 4.9.4, requiring libstdc++ version 6.0.20 or later. (2018)
- The latest Intel Message Passing Interface (MPI), version 2018 update 1, is used for process communication. The upgrade includes the removal of SMPD / MPD and the I_MPI_PROCESS_MANAGER environment variable since these are deprecated in the latest version. (2018)
- Edge loads now take port polarity into account. (2018, 2018)
- A new option is added to wait for available HyperWorks Units (HWUs) if there are not enough units available to start a solver job. Set the environment variable ALM_QUEUE_TIMEOUT to the desired waiting time (in seconds). (2018)
- The str2ascii tool is extended to support the latest .str file format (12). (2018)
- A check for overlapping triangles in simulation meshes is added. (2018)
- The MoM meshing requirements for metal faces on dielectric boundaries are relaxed. (2018)

Resolved Issues

- An internal error that could have resulted for FDTD models where the resistance, capacitance and inductance are set to zero is corrected. (2018)
- The FDTD minimum time interval was ignored if the automatically calculated maximum time interval was shorter than the specified minimum time interval. This is fixed. (2018)
- Incorrect results were calculated for PBC problems that are long relative to the periodic cell surface area. This is fixed. (2018)
- The robustness and speed of intersection tests for RL-GO models are improved. (2018)
- The automatic parameters for small RL-GO models (where RL-GO is not really applicable) are improved to produce more accurate results. (2018)
- A bug is fixed that prevented the proper detection of degenerate triangles in the mesh RL-GO and windscreen elements. (2018)
- The RL-GO warnings are improved to provide a summary of the number of rays with angular increments that are too coarse. The number of rays being affected are listed instead of issuing a warning for each ray. (2018)
- RL-GO is extended to provide more details regarding rays that are discarded during the simulation. The ray origin, direction and decay are included in the .out file. (2018)

- The performance of RL-GO is improved by not computing the magnetic dipole moment when a ray hits a PEC surface. (2018)
- A bug is fixed that caused an error while writing rays to the `.ray` file for UTD cylindrical geometry. (2018)
- SPICE models that contain special characters, such as a circumflex, in the file name no longer result in an error when using the SPICE solver. (2018)
- MoM matrix fill times are improved. (2018)
- Unused quantities are removed from the geometry and basis function sections of the OUT-file. (2018)
- The calculation of transmission/reflection coefficients for electrically small unit cells with high aspect ratios is corrected. (2018)
- A bug that caused an internal error for triangles with features smaller than the model tolerances is fixed. (2018)
- Add the environment variable `FEKO_MPI_ROOT_FORCE` to force the MPI implementation used. (2018)
- `LD_BIND_NOW` is not enabled for Feko runs on Linux systems. This is no longer required to avoid floating point exceptions. (2018)
- A correction is made to the test for the application of losses to conducting surfaces. Warning 32412 may not have been triggered when it should have for some low conductivity or high permeability examples. (2018)
- Support for the microstrip coaxial feed approximation is removed as more modern alternatives are available. (2018)

Shared Interface Changes

Features

- The API `Launcher` object is extended to allow users to access the command used to launch other Feko components. Each function returns a command string that takes the current settings into account. This extension makes it easier to integrate third party applications into the interface. (2018)
- Collections in the API are extended with a `UniqueName` method that will use the contents of the collection to find a unique name (with no duplicate) for a given base name. This removes the burden of defining a unique name from the user. (2018)
- The 3D CAD modeller used in CADFEKO is upgraded to version 30, providing access to the Parasolid formats, bug fixes and performance enhancements. (2018)
- The rendering engine is upgraded to the latest version to access the latest bug fixes and performance enhancements. (2018)

Resolved Issue

- The options `--remove-use-mpi` and `--remote-host` could have been included when remote execution was not activated. A machines file could also have been generated and used for local runs. These errors are corrected. (2018)

Support Components

Features

- The Feko updater is greatly improved in terms of speed and its ability to efficiently handle a large number of small files in an update. (2018)
- The optimisation engine is improved to make it less sensitive to extremely large or extremely small values. (2018)
- A Feko + WinProp Launcher utility allows quick and easy access to all the Feko and WinProp components, documentation and licensing utilities. The launcher eliminates clutter by greatly reducing the number of icons added to the Windows start menu. (2018)
- The installers are upgraded to use the latest version of the installation software. This version has improved support for ultra high definition (UHD) screens. (2018)
- The WinProp example models are included in the installation. In previous releases, these examples had to be downloaded from the website. (2018)
- The mat2ascii and str2ascii utilities are included in the Feko installation. In the past, these utilities had to be downloaded from the Feko website. (2018)
- The scripting examples and related PDF document are removed from the Feko installation. Any users requiring the old models and document should contact the Feko Support team. (2018)
- Third party resources, such as the NGSPICE manual, are now located in the shared/pdf folder in the Feko installation directory. (2018)
- The documentation (all Feko content) has been re-created making it easier to find content, follow steps to complete tasks. The HTML version of the documentation uses the system web browser. (2018)
- The Linux build environment is upgraded to support the new compilers and the latest library upgrades. The build environment is CentOS 6.9 with Development Toolkit 3.1. Linux systems require a GLIBC version of 2.12 or later in order to run Feko. (2018)

Resolved Issues

- Empty lines before the Touchstone specification line are supported. (2018)
- The Feko updater no longer requires a valid licence file in order for system administrators to update Feko to the latest version before installing a valid licence. (2018)
- A bug that prevented the import of materials from XML databases on Linux systems is fixed. (2018)
- The OPTFEKO help text for parallel farming runs is clarified. (2018)

WinProp 2018 Release Notes

The most notable extensions and improvements to WinProp are listed by component.

General

Features

- Feko far field results (antenna patterns) can be imported in `.ffe` format. These files contain full polarimetric information, such as antenna patterns for theta polarization and for phi polarization, to increase the breadth of suitable WinProp applications. (2018)
- WinProp (using HyperWorks units) is included in the Feko installation and gets installed to the same location. The Feko bin directory and other folder structures are shared. The legacy licensed WinProp still requires a separate installation. (2018)
- Multiple concurrent WinProp installations are now possible. (2018)
- As part of the merger of WinProp and Feko installers (for installations with HyperWorks licensing), administrative privileges are no longer required. (2018)
- Similar to other Altair HyperWorks tools, WinProp now also supports a Student Edition. (2018)

Resolved Issue

- Fixed a bug in which modified RunMS settings were sometimes not respected by the solver. (2018)

ProMan

Features

- For rigorous analysis, the full angle-dependent polarization of both the transmitting and the receiving antennas are now taken into account in indoor and urban scenarios with ray-tracing methods SRT and IRT (provided also the option Fresnel/UTD is selected). (2018)
- Transmit power is limited to 120 dBm (1 GW) to avoid unintended consequences if an unrealistic value is entered by mistake. (2018)
- Projects can be exported along with antenna patterns and geometry databases into an archive without absolute path information. This facilitates the exchange of complete projects between different machines and users. (2018)
- For simulations with empirical methods, in addition to defining a polarization for the transmitter, the user can define a cross-polarization level. (2018)
- In addition to indoor scenarios, polarization of transmitters can now also be defined in urban and rural scenarios. (2018)
- A translator is added to convert data exported from OpenStreetMap (as `.osm XML`) into WinProp readable format. (2018)
- WinProp radio channel data can be exported to the ASCII format supported by Keysight PROPSIM. (2018)

- It is now possible to export and import the properties of sites, antennas and cells. These properties can be read directly from a saved project file into another project. This saves time when setting up new projects that are similar to existing ones, and reduces the chance of errors. (2018)
- For RunMS postprocessing, multiple trajectories can now be handled. (2018)
- A velocity profile can now be included along receiver trajectories in the Virtual Drive Test (RunMS), so Doppler shift is added to the results. (2018)

Resolved Issues

- Fixed a problem that caused, in some cases, the range of the legend to be missing for a result plot. (2018)
- Fixed a problem that caused ProMan to crash while computing the propagation results for modified antennas. (2018)
- Fixed a situation where ProMan was looking for RunMS results in a folder with the default name while the user had specified a custom name. (2018)
- Fixed a situation in ProMan where the button for displaying results for selected rays was not available. (2018)
- Fixed a rare crash in an urban scenario with vegetation. (2018)
- Fixed a crash in ProMan that occurred when a user attempted to combine topographical databases with different resolutions. (2018)
- Fixed a bug that prevented the completion of a RunMS simulation for models with multiple trajectories. (2018)
- Fixed a bug that impeded receiver antenna postprocessing in area mode. (2018)
- Fixed a problem that prevented the computation of Channel Capacity in the RunMS feature. (2018)
- Fixed a situation in which an imported bitmap could no longer be displayed. (2018)
- Fixed an incorrect legend display for results in which all pixels had the same value. (2018)
- Fixed a case in ProMan where an omnidirectional antenna would continue to be displayed as a sector antenna. (2018)
- Fixed a situation in ProMan where, with certain settings, the transmitting antenna could not be moved anymore. (2018)

WallMan

Feature

- WallMan offers new shortcuts for the conversion of vector databases. (2018)

Resolved Issues

- Fixed a crash in WallMan that occurred when a furniture object overlapped with certain existing wall objects. (2018)
- Fixed a WallMan problem where changing the resolution in a database conversion could lead to an incorrect database. (2018)

AMan

Features

- Two antenna patterns, one for theta polarization and one for phi polarization, can be converted into one pattern in `.ffe` format with full polarization information. The original antenna patterns can be in several formats, such as `.msi`, `.apb` and `.apa`. (2018)
- A superposition of antenna patterns at one site can be created into one antenna pattern at that site. This avoids having to run a simulation more than once. (2018)

Application Programming Interface

Features

- A sample project developed in Visual C# shows how the WinProp API can be called or implemented in C#. (2018)
- The WinProp API can now be used under HyperWorks Units (HWU) licensing. (2018)

Feko 2017.2.5 is a bug-fix update that includes the enhancements and bug fixes documented below.

This chapter covers the following:

- [CADFEKO](#) (p. 435)
- [EDITFEKO](#) (p. 436)
- [POSTFEKO](#) (p. 437)
- [Support Components](#) (p. 438)



Note: Feko 2017.2.5 is a cumulative update that contains changes from previous updates. It should be applied to an existing installation of Feko 2017 (that may or may not have been updated previously).

CADFEKO

Resolved Issues

- The part labels for sheet bodies imported from STP file now use the face names instead of "NONE". (2017.2.5)
- The setting to calculate far fields for an array of elements did not persist for monostatic RCS calculations. The setting would be reverted each time the far field request dialog was opened. This problem is now resolved. (2017.2.5)
- CADFEKO issues an error when running OPTFEKO if any of the request labels used in an optimisation goal starts with a number. The `.opt` file is no longer created if the labels are problematic. Labels starting with a number would cause the simulation to terminate with "ERROR 21027: Error in expression" during optimisation goal calculation. (2017.2.5)

EDITFEKO

Feature

- The FM card (fast method settings) layout is simplified for the near field and far field calculation method settings. Two check boxes replace the old radio button options. The fast near field and fast far field calculation methods are simply enabled or disabled using the check boxes. (2017.2.5)

POSTFEKO

Resolved Issues

- The memory consumption for opening and closing huge sessions containing many graphs, views and results is reduced significantly. This avoids a crash of the application due to insufficient memory. (2017.2.5)
- A crash is resolved that could happen when exporting a stored S-parameter DataSet from POSTFEKO. (2017.2.5)
- Improvements to the way annotations are added to 2D graphs make it easier for annotations to be snapped to a trace. (2017.2.5)

Support Components

Feature

- A problem with HyperWorks licensing is resolved that could have resulted in a crash when insufficient licences were available to complete the licence checkout when using the solver node licensing scheme. (2017.2.5)

Feko 2017.2.4 is a bug-fix update that includes the enhancements and bug fixes documented below.

This chapter covers the following:

- [CADFEKO](#) (p. 440)
- [POSTFEKO](#) (p. 441)
- [Solver](#) (p. 442)
- [Support Components](#) (p. 443)



Note: Feko 2017.2.4 is a cumulative update that contains changes from previous updates. It should be applied to an existing installation of Feko 2017 (that may or may not have been updated previously).

CADFEKO

Features

- The Optenni Lab plugin is extended to support the Altair Partner Alliance (APA) version. The APA version of Optenni Lab uses different registry entries compared to the stand-alone version. The plugin now also supports a FEKO_OPTENNI_PATH environment variable allowing users to set the path to the Optenni Lab installation that should be used when multiple versions are installed. (2017.2.4)

Resolved Issues

- An issue with the new mesh engine is resolved that could cause large tetrahedra to be created in a region cut by a symmetry plane. (2017.2.4)
- Extremely small edges (smaller than 0.1% of the model size) are now ignored during meshing. These edges caused tiny elements to be created in CADFEKO 2017.2.2 and 2017.2.3. This was due to the change made to CADFEKO 2017.2.2 to improve the meshes generated for models containing small edges with an applied mesh size much larger than the dimension of the edge. (2017.2.4)
- A crash is resolved that could be encountered on AMD machines during voxel meshing. (2017.2.4)

POSTFEKO

Resolved Issues

- An issue is resolved that could lead to an assertion failing with "converterMap.contains(A)" when entering a unit value on the result palette that is not listed as an option for the vertical unit setting of the trace from on the ribbon (Trace tab). This assertion failure could also be encountered when setting the unit through the API. (2017.2.4)
- To avoid ambiguous quantity units, temperature units are modified to "degC", "degK" and "degF" instead of "C", "K" and "F". References to Kelvin may cease to work and replacing the unit "K" with "degK" on the result palette or in the script should resolve any problems. (2017.2.4)
- The scaling for tonne (metric ton) is corrected to 1e6 grams. (2017.2.4)
- The "Select all" (Ctrl+A) behaviour for graph traces is corrected. (2017.2.4)

Solver

Features

- The convergence speed of stabilised CFIE MLFMM examples is improved by disabling stabilisation. (2017.2.4)
- The iteratively coupled hybrid MoM/MLFMM-PO/LE-PO solutions are now also supported for cases where the MoM/MLFMM region are solved using the CFIE. (2017.2.4)

Resolved Issues

- CMA solution robustness and parallel scaling efficiency is improved. (2017.2.4)
- A segmentation violation for characteristic mode analysis problems with more than 40 000 unknowns is fixed. (2017.2.4)
- A bug is fixed that could lead to "ERROR 46104: Error while reading the matrix from a file" for CMA examples. (2017.2.4)
- The reflection coefficient for circularly polarised excitation of a circular waveguide is corrected. (2017.2.4)
- A hang is fixed for parallel runs with waveguide ports when the mode expansion settings are changed between configurations. (2017.2.4)
- The condition number of matrices is not calculated on parallel Linux systems due to a bug in Intel MKL. (2017.2.4)

Support Components

Resolved Issues

- The Feko Example Guide graphs for "Example D-1: Shielding factor of a sphere with finite conductivity" are corrected. The result on the "Shielding factor (E-field)" graph was incorrectly scaled and the unit is corrected in the "Shielding factor (H-field)" graph. (2017.2.4)
- Continuous frequency results varied for some geometries when rotated. This is fixed. (2017.2.4)
- The processing of CST near field scan data is corrected for cases where the model unit differs from the dimension unit used in the imported near field scan. (2017.2.4)
- Local parallel RSH Feko runs on Linux systems are no longer prevented when the hostname returns the fully qualified domain name by default. (2017.2.4)
- An extra console window is no longer shown by the updater when it is launched from a medium integrity process to update an application installed in a location that requires high process integrity. (2017.2.4)
- An improved error message is displayed when using the command line updater to update from a local repository without specifying the version to upgrade to for the --upgrade-from command. (2017.2.4)
- An error message is displayed when the updater is unable to write settings to the .ini file and the updater settings cannot be stored. (2017.2.4)

Feko 2017.2.3 is a bug-fix update that includes the enhancements and bug fixes documented below.

This chapter covers the following:

- [CADFEKO](#) (p. 445)
- [Solver](#) (p. 446)

 **Note:** Feko 2017.2.3 is a cumulative update that contains changes from previous updates. It should be applied to an existing installation of Feko 2017 (that may or may not have been updated previously).

CADFEKO

Resolved Issue

- An assertion failed with "getMeshElementDescriptors().count() == 1" when saving a model containing a suspect port connected to a general network or transmission line. The `.pre` file will now contain the error message "The mesh instance of port '[port label]' is suspect". (2017.2.3)

Solver

Resolved Issues

- The linear system solution numerical libraries are reverted back to the previous version due to floating point exceptions encountered on some hardware platforms. (2017.2.3)
- The first frequency impedance was incorrectly calculated for a multi-configuration problem run in parallel. (2017.2.3)
- S-parameters were calculated incorrectly when adding reference impedances to existing loads at microstrip ports. (2017.2.3)
- A division by zero error is avoided when requesting the scattered far field only for models that consist of sources only. (2017.2.3)
- The performance of the initialisation phase for the windscreen solution method is improved. (2017.2.3)
- Floating point exceptions that could have been raised on Linux systems using newer versions of glibc are resolved. (2017.2.3)

Feko 2017.2.2 is a bug-fix update that includes the enhancements and bug fixes documented below.

This chapter covers the following:

- [CADFEKO](#) (p. 448)
- [POSTFEKO](#) (p. 450)
- [Solver](#) (p. 451)
- [Support Components](#) (p. 452)



Note: Feko 2017.2.2 is a cumulative update that contains changes from previous updates. It should be applied to an existing installation of Feko 2017 (that may or may not have been updated previously).

CADFEKO

Resolved Issues

- An update to the latest version of the meshing library provides the following improvements (2017.2.2):
 - The performance of meshing large, curved surfaces such as spheres, paraboloids and reflector antennas is improved.
 - The meshing of sharp, pointed geometry, like the tips of cones is improved.
 - Some problematic faces that could not be meshed before can now be meshed.
 - A crash is resolved for meshing long, intertwined helices with the refinement factor advanced mesh setting set to a value much finer than the default.
- Improved meshes are generated for models that have small edges with a large mesh size (larger than the dimension of the edge) applied on them. (2017.2.2)
- The meshes generated for low frequency models using automatic meshing (setting the mesh size to **Fine, Standard** or **Coarse**) are improved. (2017.2.2)
- The meshing quality of triangles and tetrahedra that bound small curved surfaces is improved. (2017.2.2)
- Improved warnings are written to the message window when problems are encountered during meshing. (2017.2.2)
- The performance of re-meshing surface meshes is improved. (2017.2.2)
- The meshes generated for models with large model extents are improved:
 - The meshing of small wires in models with large model extents is improved. Error 17601, advising the user to adjust the mesh settings, could be given when meshing with curvilinear segments enabled and linear segments did not always accurately represent the geometry. (2017.2.2)
 - A meshing issue for large model extents where faces were sometimes ignored during meshing is resolved. If a similar problem is encountered, a warning will now be issued. (2017.2.2)
 - Poor meshes were generated in some instances for models with large model extents, causing the KERNEL to terminate with "ERROR 832: Segmentation rules have been violated (two triangles touch without a common edge)". This issue is resolved. (2017.2.2)
 - An assertion could fail with "!composingEntities.isEmpty()" when meshing a model with large model extents. (2017.2.2)
- A meshing issue is resolved where wire segments much shorter than the wire or the requested wire segment length were sometimes created. This could happen on a curved wire containing a segment port when the requested wire segment length was defined to be more than 80% of the wire length. These short segments caused the solver to terminate with "ERROR 116: The ratio of the segment radius to length is too large" or "ERROR 241: A segment is too short or EPSSENT is too large" when running the simulation. (2017.2.2)
- A meshing issue for UTD models is resolved. Slight intolerances in a union of UTD polygons could lead to faces being meshed into triangles instead of unmeshed plates. "Warning 18172: The UTD plate has non-straight edges and will be approximated by triangular elements" is no longer triggered during meshing if points on the geometry are within a tolerance of 1e-6. (2017.2.2)

- The "Faulty parts" dialog is given once, instead of once per faulty part, when changing the model extents to a setting that would result in the scaled model containing faults. (2017.2.2)
- An issue is resolved where an assertion could fail with "GET_SERVICE(common_ParaModellerSession)->getUndoStackDepth() == m_pOriginalAction->m_undoStackDepth" when pressing undo after a failed import. (2017.2.2)
- Coincidental edges in polylines are no longer prevented. Error 17944 that was introduced in Feko 14.0 is replaced by Warning 17944. It is not advised to use coincidental edges in the definition of a polyline, since this could lead to a geometry modeller error in some cases. (2017.2.2)
- An assertion failed with "supportsLabelScoping()" when copying a configuration specific source, load or request other than near fields, far fields, currents or error estimates to another configuration. (2017.2.2)
- The speed of FDTD grid calculation is improved for models containing many vertices. The "Create mesh" dialog will now open faster, moving past the "Generating grid..." dialog more quickly for geometry with many vertices. The dialog is also more responsive for updating the mesh settings. (2017.2.2)
- FDTD boundary conditions were being displayed when the FDTD solver was not enabled. (2017.2.2)
- CEM validate incorrectly reported "Error 19956: Dielectric faces may not be located on the interface of the planar Green's function." for models containing a multilayer substrate defined with a positive Z value at the top of layer 1 and faces at the corresponding negative Z value. (2017.2.2)
- CEM validate no longer reports an error when a cable harness is defined to use the MTL method to consider irradiating effects while the FDTD solver is enabled. MTL with FDTD (irradiation solution) is supported since Feko 2017.2. (2017.2.2)
- The general solver setting "Read *.pul file if it exists, else create it" introduced in Feko 2017.1 was not applied unless another output file setting was set to something other than **Normal execution**. (2017.2.2)
- The opening speed is improved for models containing frequency settings specifying an extremely large number of frequency points. (2017.2.2)
- An API issue that caused an increase in run-time and memory usage when successively returning specific face objects from a collection of faces is fixed. The problem was encountered when using the face labels to identify the faces. (2017.2.2)

POSTFEKO

Resolved Issue

- POSTFEKO failed to open some sessions saved in POSTFEKO 2017.2. The error message "Error 16314: The file contains an unsupported *.pfs file version." was encountered when attempting to open `.pfs` files containing near field time analysis graphs with traces displaying magnetic field, electric field or Poynting vector quantities. These saved POSTFEKO sessions can now be opened. (2017.2.2)

Solver

Feature

- The linear system solution numerical libraries are updated. (2017.2.2)

Resolved Issues

- A bug is fixed that could have caused incorrect results for MoM/MLFMM examples run in parallel with MPI-3 shared memory activated. (2017.2.2)
- A near field aperture was prevented from calculating the received power from the scattered field only. (2017.2.2)
- A bug is fixed that might have caused incorrectly calculated losses for MoM HOBF 1.5 and 3.5 triangular elements. (2017.2.2)
- Non-radiating networks are not allowed on edge ports connected at SEP dielectric boundaries. This is prevented by the explicit error 52602. (2017.2.2)
- PEC geometry is allowed to pass through FEM modal ports. (2017.2.2)
- The robustness of curvilinear search algorithms is improved. (2017.2.2)
- Material search functions are improved so that correct material checking is done if windscreen material specification is not set correctly. (2017.2.2)

Support Components

Resolved Issues

- ADAPTFEKO ended in an error state if a continuous frequency range follows a discrete list of frequencies. (2017.2.2)
- Resolved a problem with the interpretation of units when importing a custom array from file in the FA card. (2017.2.2)

Feko 2017.2.1 is a bug-fix update that includes the enhancements and bug fixes documented below.

This chapter covers the following:

- [Solver](#) (p. 454)

 **Note:** Feko 2017.2.1 is a cumulative update that contains changes from previous updates. It should be applied to an existing installation of Feko 2017 (that may or may not have been updated previously).

Solver

Features

- Memory usage is reduced for shared memory runs when Intel MPI is used. (2017.2.1)
- Improved algorithms are used for geometry processing prior to calculation. (2017.2.1)
- Memory consumption of the model geometry check process for CFIE problems is reduced and runtime is improved. (2017.2.1)

Resolved Issues

- Error 34357 was incorrectly issued for PBC examples that have metallic triangles the background medium connected to dielectric triangles. (2017.2.1)
- A bug is fixed that caused a floating point internal error while calculating far fields on certain Intel platforms. (2017.2.1)
- Several memory leaks for FDTD problems are fixed. (2017.2.1)
- Impedance calculations were incorrect for FDTD ports that consist of multiple sections with some sections consisting of only one voxel. (2017.2.1)
- An internal floating point error that occur during the fast far field calculation is fixed. (2017.2.1)
- An error regarding an incorrectly meshed curvilinear triangle was not issued on Linux systems. (2017.2.1)
- An incorrect S-parameter transmission coefficient was calculated for higher order waveguide ports if the higher order mode excitation was defined as a receive port only. (2017.2.1)
- Runtime reporting is improved when exporting rays in parallel for RL-GO. (2017.2.1)
- An internal error state occurred for large element physical optics problems if the solution was read from `.str` file. (2017.2.1)

The Feko 2017.2 update includes the features, enhancements and bug fixes documented below.

This chapter covers the following:

- [CADFEKO](#) (p. 456)
- [EDITFEKO](#) (p. 457)
- [POSTFEKO](#) (p. 458)
- [Solver](#) (p. 459)
- [Support Components](#) (p. 460)

Prominent features

- Custom user specification of the convergence criteria for the finite difference time domain (FDTD) solver.
- Improved support for PEC regions embedded in dielectric regions for the finite element method (FEM).

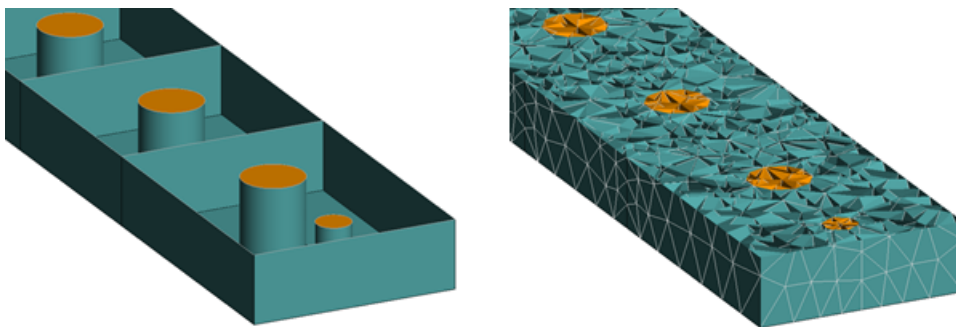



Figure 89: Partial view of a coaxial diplexer model (left) and mesh (right) with the perfect electric conductor pins meshed into tetrahedra with the dielectrics and solved as part of the FEM solution.

 **Note:** Feko 2017.2 is a cumulative update that contains changes from all previous releases. It can be applied as an update to an existing installation of Feko 2017 or it can be installed without first installing Feko 2017.

CADFEKO

Features

- Support for setting FEM regions to the **Perfect electric conductor** medium. FEM PEC regions are meshed into tetrahedra, but do not add to the number of unknowns in the FEM solution. (2017.2)
- The advanced solution frequency settings are extended with options to specify the minimum time interval, the maximum time interval and the convergence threshold for FDTD simulations. (2017.2)
- The near field optimisation goal is extended to support optimisation of (normalised) electric and magnetic flux density. (2017.2)
- The far field optimisation goal is extended to support the optimisation of realised gain. (2017.2)
- The API is extended to provide rational interpolation functionality to the scripting environment.
- The meshing library is upgraded to the latest version. (2017.2)

Resolved Issues

- A problem with the file browser file extension filter for mesh imports is resolved. The filters for CADFEKO mesh (.cfm) and (.fek) files did not show files of these types in the file browser when opening files to import. (2017.2)
- An issue is resolved with configuration specific cable sources that could trigger "ERROR 38353: Multiple cable sources defined at the same connector pin combination are not allowed" during the simulation. (2017.2)
- An issue is resolved that prevented changes from being made to the medium properties of a face. The problem was encountered when creating a cone or flare primitive with the top dimension set to zero and then modifying this dimension to be non-zero. The face created during this modification would have "Perfect electric conductor" medium properties and changes to the face medium would not be applied. (2017.2)

EDITFEKO

Features

- The ME card (dielectric region) is extended to allow defining perfect electric conductor FEM tetrahedra. (2017.2)
- The FD card (FDTD settings) is extended with the options to specify the minimum time interval, the maximum time interval and the convergence threshold for FDTD simulations. (2017.2)

POSTFEKO

Features

- Support the display of electric and magnetic flux densities for near field graphs and views. (2017.2)
- The file size is reduced for POSTFEKO `.pfs` files sessions that contain imported data. (2017.2)
- The API is extended to provide rational interpolation functionality to the scripting environment.
- The `.fek` file version is increased to 158 to accommodate new features. (2017.2)

Resolved Issues

- The visualisation of stored data for near field requests using local workplanes is corrected. (2017.2)
- An issue with cable probes used across multiple configurations is resolved. If cable paths were swapped between configurations, probe results could be incorrectly labelled, associated with the wrong configuration or not be available for plotting. (2017.2)

Solver

Features

- Improved handling of PEC regions embedded in FEM solution domains. (2017.2)
- Custom user specification of the FDTD convergence criteria is supported. (2017.2)
- Support is added to the FDTD solver for left/right handed polarisation and ellipticity of a plane wave source. (2017.2)
- Irradiation MTL cable analysis for frequency domain FDTD is supported. (2017.2)
- The stabilised MLFMM now supports specifying the residuum for the stopping criteria. (2017.2)
- The MUMPS sparse LU preconditioner is used for extremely large MLFMM problems (more than $2^{31}-1$ matrix entries) instead of the fall-back SPAI preconditioner. (2017.2)
- Various computational libraries are upgraded to improve support for large models run with the FEM and MLFMM. (2017.2)

Resolved Issues

- An issue causing incorrect reflection coefficient phase values for the planar Green's function when the phase reference is not set to $z=0$ is resolved. (2017.2)
- A bug is fixed that caused incorrect results (small differences) for physical optics problems connected to a ground plane. (2017.2)
- An issue is resolved that caused an internal error state when solving certain MLFMM models containing dielectric media in parallel. (2017.2)
- Incorrect transmission coefficients reported for a negative incident theta angle are resolved. (2017.2)
- An internal error condition that occurred when setting all ports active for S-parameter requests with four or more ports is fixed. (2017.2)
- Memory usage of the out-of-core pre-conditioner used for large MLFMM problems is improved. (2017.2)
- Parallel memory reporting is improved at various stages for distributed MPI parallel examples. (2017.2)
- A memory location fault encountered for certain MLFMM problems that use the MUMPS preconditioner is prevented. (2017.2)
- Rays were missing from `.ray` and `.bof` files when using distributed parallel MPI Feko runs. (2017.2)
- An issue is resolved that caused parallel Feko runs to terminate because a host list file could not be written. (2017.2)
- An error regarding the size of the mesh in relation to the number of processes used was issued incorrectly for certain small FDTD examples. (2017.2)

Support Components

Feature

- A shared Lua module gives the user access to common actions. The module provides the ability to read values from an ASCII file. (2017.2)

Feko 2017.1.2 is a bug-fix update containing the fix described below.

This chapter covers the following:

- [CADFEKO](#) (p. 462)



Note: Feko 2017.1.2 is a cumulative update that contains changes from previous updates. It should be applied to an existing installation of Feko 2017 (that may or may not have been updated previously).

CADFEKO

Resolved Issues

- A regression that was introduced in the 2017.1.1 update is resolved. Volume meshing created overlapping tetrahedra when using the default mesh engine to mesh regions entirely enclosed in another region. (2017.1.2)

Feko 2017.1.1 is a bug-fix update that includes the enhancements and bug fixes documented below.

This chapter covers the following:

- [CADFEKO](#) (p. 464)
- [POSTFEKO](#) (p. 466)
- [Solver](#) (p. 467)
- [Support Components](#) (p. 468)



Note: Feko 2017.1.1 is a cumulative update that contains changes from previous updates. It should be applied to an existing installation of Feko 2017 (that may or may not have been updated previously).

CADFEKO

Resolved Issues

- A regression in Feko 2017 that meshes of locked parts are removed when the solution frequency changes is resolved. (2017.1.1)
- An issue with models containing **Feko Solver field on Cartesian boundary** near field data (introduced in Feko 14.0.421) is resolved. The models could not be opened in the same version of the application that was used to save them. (2017.1.1)
- The constrained surface tool conditions are relaxed for issuing Error 16898 when conflicting U' or V' parameter values or axis directions are identified. The error was not encountered when first adding all points of a constrained surface and then defining the surface parameters according to the U'V' axes preview, but was easily triggered when adding points to a constrained surface with specified surface parameters. The U' and V' axes are now updated to comply with the specified surface parameter values, allowing the user to add points to previously defined constrained surfaces. (2017.1.1)
- Curvilinear segment meshing is supported with windscreens. Curvilinear mesh segments were introduced in Feko 14.0, but were initially not supported for windscreen antennas. Support in the Solver for curvilinear wires as part of windscreen antennas was added in Feko 14.0.420, but CADFEKO was not extended to create curvilinear segments during meshing when windscreens were present. (2017.1.1)
- Any meshed PEC region containing a wire and somehow depending on a variable would give "Error 17901: Surrounding medium has an invalid value" when attempting to modify the variable. This is fixed and the variables can be modified. (2017.1.1)
- The Feko 2017 setting to use the legacy mesher was not saved if this was the only change to a model. (2017.1.1)
- For some models, meshing with curvilinear segment meshing enabled could terminate CADFEKO with "Assertion failed: edgeType == MESH_ELEMENT_TYPE_EDGE3". This assertion is changed to Error 17601, with a message that indicates the problematic wire. (2017.1.1)
- An issue with the default mesher that could yield collapsed triangles is resolved. The collapsed triangles would lead to the solver terminating with "ERROR 240: A triangle is too small or EPSMENT is too large". (2017.1.1)
- The likelihood of encountering "Error 18176: Volume meshing failed" when meshing a FEM model with the new mesh engine is reduced. (2017.1.1)
- Meshing of parts, such as open periodic cylinders, that terminate in continuous, closed edges on periodic boundaries are now handled correctly by the default mesher. In the initial Feko 2017 release, mesh entities forming a closed loop on a periodic boundary did not always line up and the simulation would terminate with "ERROR 832: Segmentation rules have been violated (two triangles touch without a common edge)". (2017.1.1)
- An assertion is fixed that failed with "found == true" when using the default mesh engine to mesh some models using periodic boundary conditions. This affected models where the unit cell contains parts that terminate on the periodic boundary and have the same dimensions, but different material parameters. (2017.1.1)

- A problem with the interpretation of units when importing a custom array from file is resolved. (2017.1.1)
- Gerber files lacking a unit directive could not be imported. Millimetre will now be assumed if the unit is not specified in the file. A warning message is displayed on the import dialog to indicate to the user when the unit is undefined and millimetre is assumed. If the geometry in the Gerber file is defined in inches, the user can scale the geometry after import, or, to import in inches, ensure that the unit is specified in the Gerber file. (2017.1.1)

POSTFEKO

Resolved Issues

- A new option allows enabling OpenGL rendering for accelerated performance when working with 2D graphs containing thousands of sample points. (2017.1.1)
- Forms in the API are extended. The **FormDataSelector** shows only available data by default. The boolean **IncludeMissingData** property is introduced to control the inclusion of results that are not valid or available at the time that the form data selector is populated. The new **Refresh** method repopulates the data selector with relevant items. (2017.1.1)
- Polar graph chart images are fixed. Attempting to add chart images in model reference to data cut orientation for near field results defined using cylindrical or conical coordinates terminated POSTFEKO with "src\common_AxisSet.cpp (225): Assertion failed: index != -1". (2017.1.1)
- Corrected the 3D view display of single point near field requests. Single near field points specified in conical coordinates were displayed as black dots, instead of matching the legend colour. In Feko 14.0.401 and later, when a single point near field result (specified in coordinates other than conical) was added to a 3D view, nothing was displayed. This is fixed. (2017.1.1)
- Custom **DataSets** containing custom axes can be plotted on Cartesian surface graphs. Before the fix, custom data could only be plotted on a Cartesian surface graph if the axes were standard axes like Frequency, X, Y or Z. (2017.1.1)
- A problem with the export of large datasets (results containing many points) that could cause POSTFEKO to crash, giving a critical error "Assertion failed: 0", is resolved. Large sets of near field and far field data can now be exported successfully, storing GBytes of data to file. (2017.1.1)
- An assertion that could fail with "!m_pSelectedResultEntities.isEmpty()" when adding result entities from the **Add result entity** dialog. This dialog can be accessed to browse through the available results when multiple results of the same type are present. It could happen before that no result was selected at the time of adding, which led to the assertion failing. The **Add** button is now only enabled when a valid result is selected. (2017.1.1)

Solver

Resolved Issues

- An integer overflow for RL-GO examples run in parallel with more than $2^{31}-1$ launched rays caused incorrect results. (2017.1.1)
- A bug is fixed that caused incorrect results when MoM were used with VEP tetrahedra in parallel and low frequency stabilisation was active. (2017.1.1)
- Incorrect values were calculated for surface losses on metallic triangles (due to coatings) when run in parallel. (2017.1.1)
- An internal error condition issued during the Kley shield capacitance calculation phase for certain complicated cable modelling examples is avoided. (2017.1.1)
- A floating point error issued for extremely large examples in terms of wavelength solved using the MLFMM is avoided. (2017.1.1)
- A sporadic segmentation violation that occur on the Intel(R) Core(TM) i7-3770K CPU is fixed. (2017.1.1)
- The robustness of the UTD corner diffraction contribution calculation algorithm is improved. (2017.1.1)
- The robustness of source placement checks for multiple configuration problems is improved. (2017.1.1)
- Geometry error checking for waveguide port problems is improved. (2017.1.1)
- Memory reporting for fast far field calculation is improved. (2017.1.1)
- Error report handling in memory constrained environments is improved. (2017.1.1)
- .isd file export is improved when a list type frequency selection is used. (2017.1.1)
- An error is now issued when the PO approximation is not valid because the requested frequency is too low. (2017.1.1)

Support Components

Resolved Issue

- Using the `runfeko` command with `--execute-cadfeko_batch` will no longer execute CADFEKO_BATCH between adaptive frequency (ADAPTFEKO) runs. (2017.1.1)

Feko 2017.1 is a feature and bug-fix update that includes the features, enhancements and bug fixes documented below.

This chapter covers the following:

- [CADFEKO](#) (p. 470)
- [EDITFEKO](#) (p. 472)
- [POSTFEKO](#) (p. 473)
- [Solver](#) (p. 474)
- [Shared Interface Changes](#) (p. 476)
- [Support Components](#) (p. 477)

 **Note:** Feko 2017.1 is a cumulative update that contains changes from all previous releases. It can be applied as an update to an existing installation of Feko 2017 or it can be installed without first installing Feko 2017.

CADFEKO

Features

- A new output file option on the "Solver settings" dialog allows cable per-unit-length parameters to be read from or saved to a .pul file. (2017.1)
- The meshing library is upgraded to the latest version. (2017.1)
- The parameter sweep plugin is updated to benefit from the relaxed limit on the number of "DataSet" object axes, allowing more variables to be swept. "DataSet" objects were extended in Feko 2017 to allow up to a maximum of 12 axes. The plugin can now be used for certain problem types that were not supported in the past due to this restriction. (2017.1)

Resolved Issues

- The performance of dialogs accepting NASTRAN point import is improved. A noticeable speed up will be experienced when working with large numbers of points to define polylines, polygons, fitted splines, imprinted points, cable paths or polyline refinement meshing rules. An import that could have taken several minutes to process will now finish in seconds. (2017.1)
- A problem with STEP import is resolved. An error will be given if the imported geometry falls outside of the model extents. Scaling is applied correctly to take the model unit into account. (2017.1)
- The 3D mouse sensitivity setting is fixed to be applied correctly. (2017.1)
- Geometry vertices were sometimes incorrectly removed during a union operation. (2017.1)
- Mesh wire segments crossing multilayer substrate layers were sometimes created during meshing. It was necessary to imprint points on the wires where they crossed the boundaries of the different layers to obtain a valid mesh. The mesh engine now takes care of this automatically. (2017.1)
- The error feedback for KBL cable harness import is improved. If some elements fail during KBL import, instead of giving an error that the import failed, warnings will be given for the failed elements. (2017.1)
- The following issues relating to the "Replace mesh" feature released in Feko 2017 are resolved:
 - An assertion that could fail with "m_pMeshModel != NULL" during meshing when a valid location for a mesh segment port could not be found on the replacement mesh is resolved. (2017.1)
 - An assertion that failed with "cf_MeshSegmentPort.cpp (1075): Assertion failed: found" is resolved. This could happen when incorrectly attempting to replace a mesh with wire ports applied to it with a mesh that does not contain wire segments. An error will now be given that a valid port segment must be specified. (2017.1)
 - An assertion failed with "cf_Application.cpp (729): Assertion failed: 0" when replacing a mesh containing straight wire segments with a mesh containing curvilinear wire segments or vice versa. (2017.1)
 - A rollback error is resolved that caused an assertion to fail with a message referring to "gaia_DefaultModelUndoAction.cpp (34)". This could occur during mesh replacement when a valid location for a mesh segment port could not be found on the replacement mesh. (2017.1)

- The "Use model mesh" state (that determines whether a model mesh can be re-meshed, or if the model mesh is used as simulation mesh) from the original mesh is now used, instead of that of the replacement mesh. (2017.1)

EDITFEKO

Features

- The PS card (data structure output control) is extended to allow cable per-unit-length parameters to be read from or saved to a .pul file. (2017.1)

POSTFEKO

Features

- Extensions to the API: New methods are added for exporting `.mat` files. Matrices, complex matrices, datasets and tables (that may contain numbers or strings) can be exported to `.mat` file. (2017.1)
- Extensions to the API: The name of a dataset axis can now be modified in addition to its unit and values. (2017.1)

Resolved Issues

- Cut planes are corrected to cut through RL-GO PEC and metal surfaces. (2017.1)
- The speed of working with time signals that are specified by a large number of points is improved by not always showing the table of points. The user can select to show the values for viewing and modification. The import dialog for manually specifying time signals is extended to filter based on `.csv` files when browsing for a file to import. (2017.1)
- Cut planes is corrected to cut through windscreen layers (for the layer visualisation introduced in Feko 2017). (2017.1)
- The preferences "Round off legend range and step size" setting was not correctly applied to new 3D views, resulting in the rounding of all 3D view legend entries. The setting would apply when any change was made to the settings affecting the 3D view legend range. The setting can now successfully be disabled as a default preference. (2017.1)
- The sampling for calculating the power in the spectrum of time signals now uses the sampling value specified by the user instead of automatically determining the number of samples to use. It is less likely that users will encounter "Warning 17782: The defined time signal has rapid value changes. Limiting upper frequency domain content to 100GHz." and "Error 17173: The defined signal requires too many samples for an accurate representation." (2017.1)
- Extensions to the API: Improved options are available to read data from `.mat` file and to manipulate the imported data. (2017.1)
- An assertion failed with "common_RangeOf.hxx (70): Assertion failed: min < m_maxValue" when opening a POSTFEKO session containing a 3D view with wire currents plotted in dB is resolved. (2017.1)
- An assertion failed with "common_AxisSet.h (232): Assertion failed: 0" when storing a near field dataset containing non-numeric values in one of its first three axes. (2017.1)
- Validation is added to prevent the entries of a DataSet axis that has a unit to be populated with string values. If an axis has a unit, only numeric values are accepted. Attempting to plot a DataSet with string axis entries on a Cartesian surface graph or 3D view could have led to an empty graph or an assertion failing. (2017.1)
- POSTFEKO froze when time analysis near field potential results were loaded. (2017.1)
- Error messages that displayed hashes (#####) are corrected to display the applicable error number. (2017.1)

Solver

Features

- A new cache file for cable per unit length parameters is added to speed up continuous (ADAPTFEKO) calculations by preventing the recalculation of the parameters for each frequency. (2017.1)
- Aperture source optimisation is allowed for PO/LE-PO except for the iterative hybrid MLFMM-PO/LE-PO method. (2017.1)
- Network voltage sources are supported with the RL-GO. (2017.1)
- Each request for currents and charges is stored to a separate .os and .ol file. The file naming convention is the same as for other requests stored per request basis: <FEKO_base_filename>_<requestname>(k).<extension>. (2017.1)

Resolved Issues

- Memory usage is improved for large MoM and MLFMM models. (2017.1)
- Memory usage is improved for large MLFMM problems solved in parallel. (2017.1)
- Memory consumption and allocation reporting are improved for fast far field calculations for the MLFMM. (2017.1)
- The robustness for FEM modal port eigenmode calculations is improved. (2017.1)
- The robustness of cable handling when detecting nearby geometry is improved.
- The criteria used for geometry requirements at cable terminations are slightly relaxed. (2017.1)
- Geometry checking failed when a model contained a wire consisting of a single segment connecting to a face. (2017.1)
- An internal error given when multiple configurations used sources with the same field data (such as point sources with defined radiation patterns) is resolved. (2017.1)
- A segmentation violation was triggered for models with multiple configurations where sources are moved between configurations. (2017.1)
- A bug is fixed that caused an error state when anisotropic material is used for the FEM region in some FEM/MoM hybrid models. (2017.1)
- Incorrect results were obtained when using the FDTD to solve an anisotropic material defined using the complex tensor definition type. (2017.1)
- An internal error given for parallel FDTD examples where a perpendicular PEC boundary condition is used with a far field request is resolved. (2017.1)
- The megacells per second (MCPS) calculation for FDTD results computed on a GPU is corrected. (2017.1)
- A bug that resulted in small errors for multilayer isotropic thin dielectric sheets is fixed. (2017.1)
- An issue is resolved that caused incorrect near fields to be calculated when 2D anisotropic thin dielectric sheets (TDS) are used with the RL-GO. (2017.1)
- A bug is fixed that resulted in an internal error state for certain RL-GO examples. (2017.1)
- An issue causing slight inaccuracies for curvilinear RL-GO is resolved. (2017.1)

- Suppressed warnings about the spherical cut-off region that were incorrectly generated for internal spherical mode transformations. (2017.1)
- An internal error is resolved that occurred when solving certain low frequency ACA problems. (2017.1)
- A bug is resolved that could have been triggered on the second solution frequency causing the ACA to fail. (2017.1)
- An issue is resolved for some Linux systems such as Ubuntu where parallel runs would hang. (2017.1)
- A bug is fixed that caused problems when writing binary `.lud` or `.mat` files in parallel when the number of unknowns are small compared to the number of processes used. (2017.1)
- I/O errors that were triggered sporadically when running problems in parallel are resolved. (2017.1)
- Incorrect transmission and reflection coefficients were calculated for periodic boundary examples rotated and shifted using a coordinate transformation. (2017.1)

Shared Interface Changes

Resolved Issue

- An issue with the termination of sequential iterative solutions is resolved. Pressing the "Stop" button in the GUI or Ctrl+C in the console when a iterative run has passed the threshold (the square root of the target residuum) will cause Feko to use the current solution and continue with the rest of the simulation. (2017.1)

Support Components

Features

- The CADFEKO Student Edition now allows the importing of Parasolid CAD geometry. (2017.1)
- HyperWorks licensing is updated to use the Altair License Management System 13.1. Components using ALM 13.1 are compatible with servers running Altair License Server 13.0. (2017.1)